

Chefree Technology Corp.

TFT COLOR LCD MODULE

MODEL: CH121CLGLWH-CA1

(Complied with RoHS)

WXGA
LVDS interface

Version: P00

Customer : _____

Approved By : _____

Date: _____

CHEFREE		
APPROVAL	CHECKER	PREPARE
Tim	Mark	Benson

CONTENTS

1. RECORD OF REVISION	1
2. MECHANICAL SPECIFICATIONS	2
3. OUTLINE DIMENSIONS	3
4. INTERFACE PIN CONNECTION	4
5. BLOCK DIAGRAM	5
6. ABSOLUTE MAXIMUM RATINGS	6
7. ELECTRICAL CHARACTERISTICS	7
8. OPTICAL CHARACTERISTICS	8
9. TOUCH PANEL SPECIFICATIONS	11
10. TIMING SPECIFICATIONS	12
11. RELIABILITY TEST	15
12. PRECAUTIONS FOR USE	16



2. MECHANICAL SPECIFICATIONS

(1)	Number of Dots	1280(H) x 800(V)
(2)	Module Size(mm)	278(H) x 185.59(V) x 13.9 (D)
(3)	Active Area(mm)	261.12(H) x 163.2(V)
(4)	Pixel Pitch(mm)	0.204(H) x 0.204(V)
(5)	LCD Model	TFT, Normally Black
(6)	Backlight Color	White LED
(7)	Viewing Direction	ALL Direction
(8)	Electrical Interface	LVDS Interface
(9)	Color Configuration	R.G.B Stripe
(10)	Touch Panel Mode	Built – in EETI 80W46 Controller
(11)	Module Weight(g)	TBD

3. OUTLINE DIMENSIONS

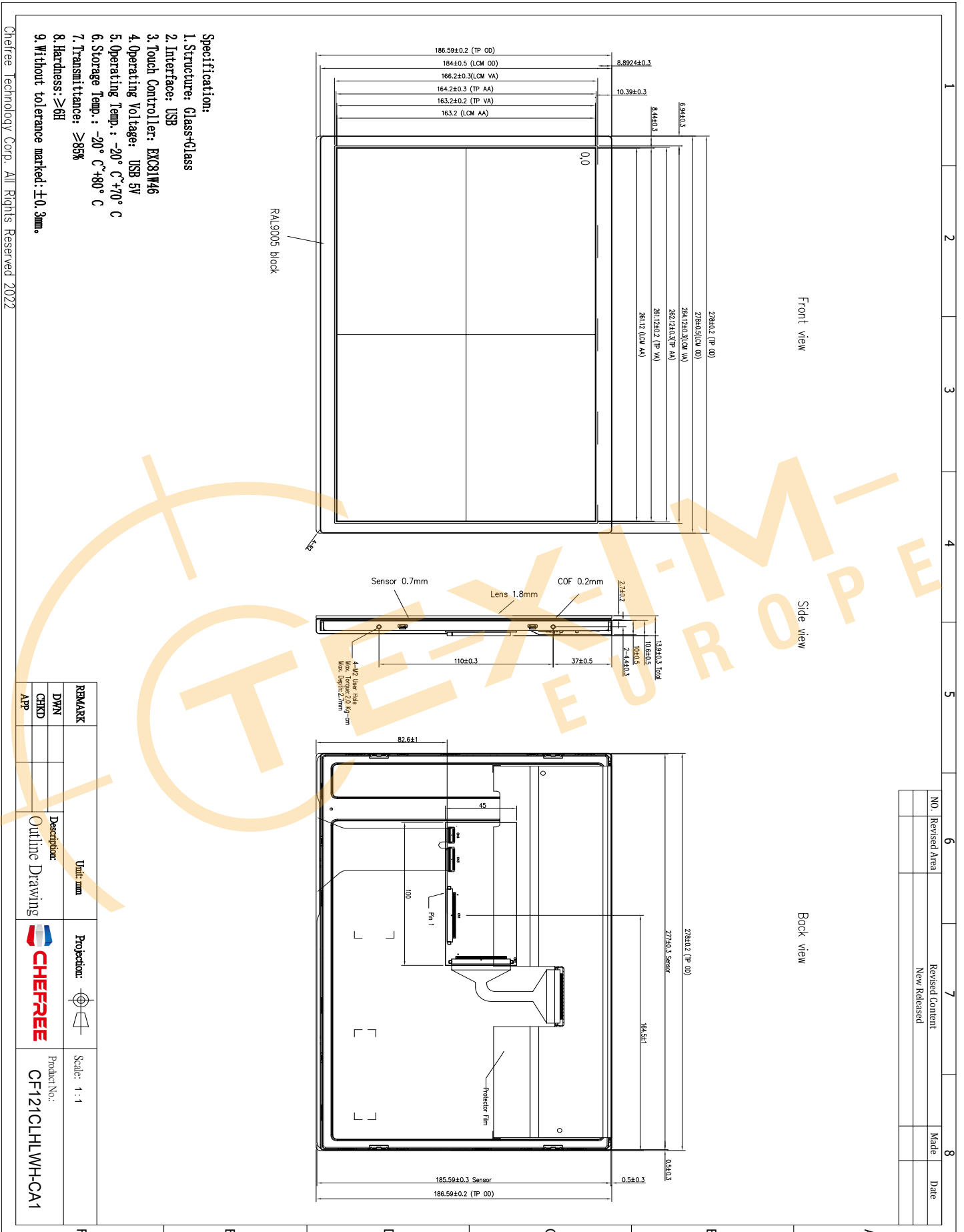

4. INTERFACE PIN CONNECTION

4.1 TFT LCM PANEL PIN DEFINE

CN1 Connector : STM MSBK2407P30 RF:HB or Equivalent

PIN NO.	Definition	I/O	Description	Remark
1	GND	P	Ground	
2	SEL6/8	I	6/8 bit select function Low: 6bit mode High: 8bit mode	
3	EN	I	Enable Control for Backlight	
4	PWM	I	Brightness Control for Backlight	
5	VLED	P	Power Supply for LED Backlight (12V)	
6	VLED	P	Power Supply for LED Backlight (12V)	
7	VDD	P	Power Supply for Digital Circuit (3.3V)	
8	NC	-	No connection	
9	NC	-	No connection	
10	GND	P	Ground	
11	RxIN0-	I	Negative LVDS Differential Data Input	
12	RxIN0+	I	Positive LVDS Differential Data Input	
13	GND	P	Ground	
14	RxIN1-	I	Negative LVDS Differential Data Input	
15	RxIN1+	I	Positive LVDS Differential Data Input	
16	GND	P	Ground	
17	RxIN2-	I	Negative LVDS Differential Data Input	
18	RxIN2+	I	Positive LVDS Differential Data Input	
19	GND	P	Ground	
20	RxCLK-	I	Negative LVDS Differential Clock Input	
21	RxCLK+	I	Positive LVDS Differential Clock Input	
22	GND	P	Ground	
23	RxIN3-	I	Negative LVDS Differential Data Input	
24	RxIN3+	I	Positive LVDS Differential Data Input	
25	NC	-	No connection	
26	NC	-	No connection	
27	VCC	P	Power Supply for PCAP	
28	D-	I	Data-	
29	D+	I	Data+	
30	GND	P	Ground	

Note : 'P' stand for Power, 'I' stand for Input

5. BLOCK DIAGRAM

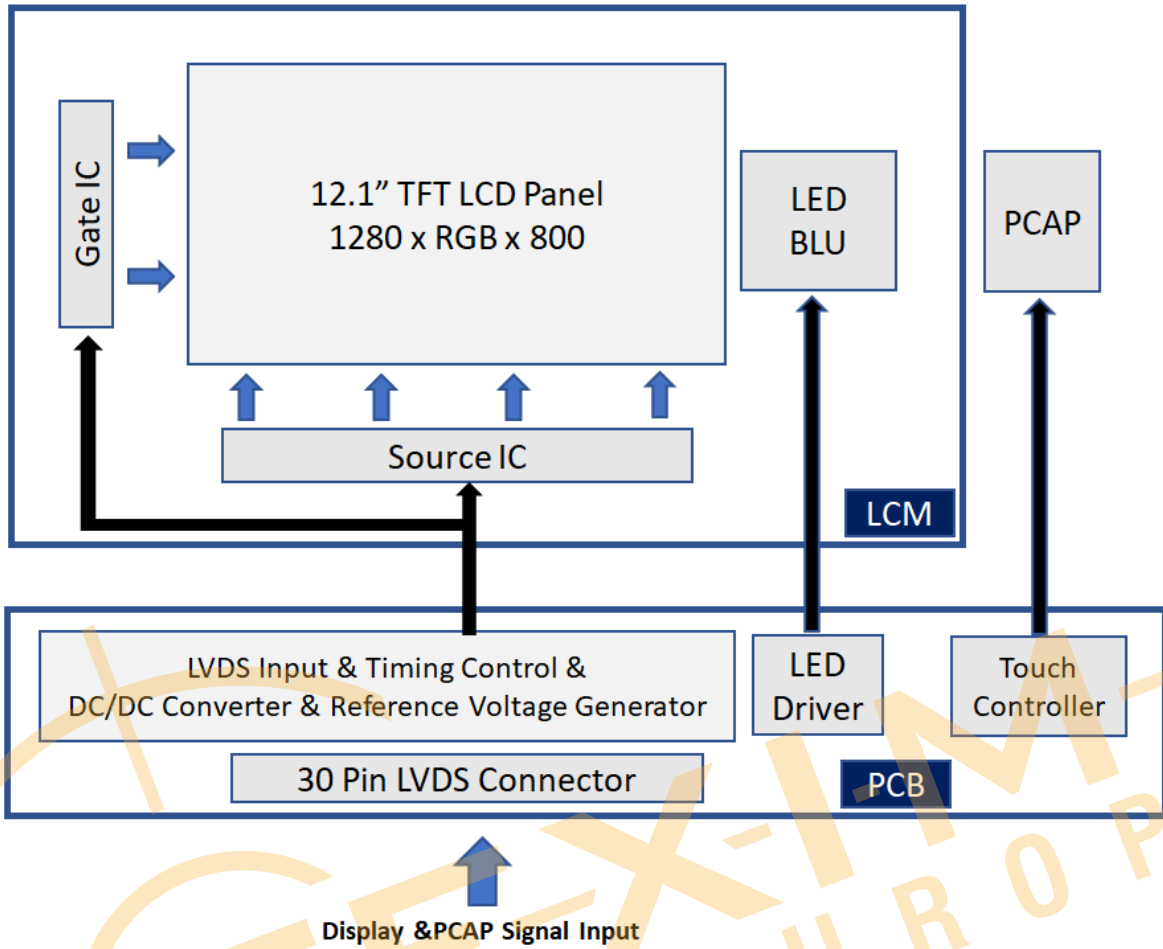

6. ABSOLUTE MAXIMUM RATINGS

6.1 ELECTRICAL ABSOLUTE MAXIMUM RATINGS

ITEM	SYMBOL	MIN.	MAX.	UNIT	REMARK
Power Supply Voltage	VDD	-0.3	4.0	V	
Backlight Supply Voltage	VLED	-0.3	18	V	
Power Voltage For CTP	/	/	/		

Note : The absolute maximum rating values of this product not allowed to be Exceeded at any times. Should be module be used with any of absolute maximum ratings exceeded. The characteristics of the module may not be recovered, or in an extreme case, the module may be permanently destroyed.

6.2 ENVIRONMENTAL ABSOLUTE MAXIMUM RATINGS

ITEM	OPERATING		STORAGE		REMARK
	MIN.	MAX.	MIN.	MAX.	
Ambient Temperature(°C)	-20	70	-20	80	Note 1,2
Humidity(% RH)	5~90(Note3)		5~90(Note 3)		-

Note 1 : The response time will become lower when operated at low temperature.

Note 2 : Background color changes slightly depending on ambient temperature.

Note 3 : Storage Ta=60°C & RH=90% ≤ 240Hrs

7. ELECTRICAL CHARACTERISTICS

7.1 ELECTRICAL CHARACTERISTICS OF LCD

Ta=25°C

ITEM	SYMBOL	MIN.	TYP.	MAX.	UNIT	REMARK
Power Voltage For LCD	VDD	3.0	3.3	3.6	V	
	IDD	-	(550)	-	mA	Note1
Differential Input Threshold	VTH	-	-	+100	mV	Note2
	VTL	-100	-	-	mV	
Magnitude Differential Input	V _{ID}	100		600	mV	
Common Mode Voltage	V _{CM}	1.125	-	1.375	V	

7.2 BACKLIGHT UNITS

Ta=25 °C

ITEM	SYMBOL	MIN.	TYP.	MAX.	UNIT	REMARK
LED Driving Voltage	VLED	-	12	-	V	
LED Driving Current	ILED	-	(0.95)		A	
Backlight ON/OFF	EN	2.9	3.3	5.0	V	
		0	-	0.4	V	
Backlight Control	DIM	2.9	3.3	5.0	V	
		0		0.4	V	
LED Life Time	-	(30,000)	-	-	Hrs	Note1
PWM Frequency	-	200	-	1000	Hz	

Note 1: The LED life time define as the estimated time to 50% degradation of initial luminous.

Note 2: Operating temperature 25°C, humidity 55%RH.

7.3 CTP ELECTRICAL CHARACTERISTICS

ITEM	SYMBOL	MIN.	TYP.	MAX.	UNIT	REMARK
Power Voltage For PCAP	VCC	/	5.0	/	V	

8. OPTICAL CHARACTERISTICS

8.1 Optical specification

Ta=25°C

ITEM	SYMBOL	CONDITIONS	MIN.	TYP.	MAX.	UNIT	REMARK
Contrast Ratio	CR		800	1000	-	-	Note 2,5
Response Time	TR		-	15	-	ms	Note 3
	TF			10	-	ms	Note 3
Chromaticity	Red	x	Viewing Normal Angle $\Theta_x = \Theta_y = 0^\circ$	-0.05	+0.05	-	Note 1,5
		y					
	Green	x					
		y					
	Blue	x					
		y					
Chromaticity	White	x	0.313	-	-	-	
		y	0.329	-	-	-	
Viewing Angle	Hor.	θ_{x+}	-	85	-	Deg.	Note 1,5
		θ_{x-}	-	85	-		
	Ver.	θ_{y+}	-	85	-		
		θ_{y-}	-	85	-		
Luminance	Lc	PWM=100%	-	1000	-	cd/m ²	Note 4,5
White Variation	W	$\Theta_x = \Theta_y = 0^\circ$	1.25	1.4	-	-	Note 5,6

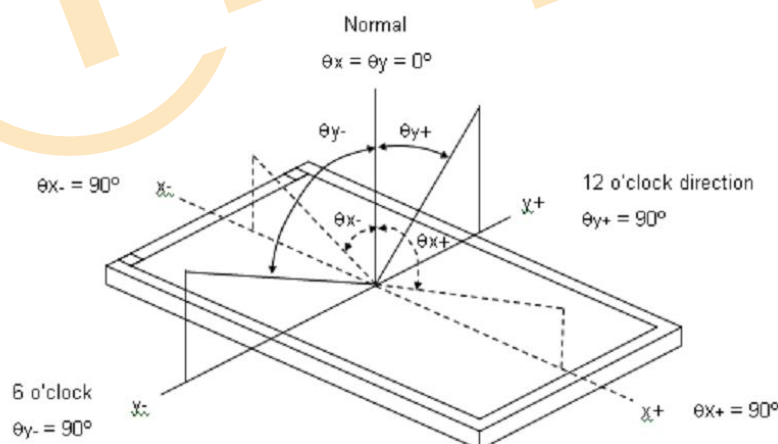
 Note 1 : Definition of Viewing Angle (Θ_x, Θ_y)

Note 2 : Definition of Contrast Ratio (CR)

The contrast ratio can be calculated by the following expression.

$$\text{Contrast Ratio (CR)} = L_{63} / L_0$$

L63: Luminance of gray level 63

L0: Luminance of gray level 0

$$\text{CR} = \text{CR} (5)$$

CR (X) is corresponding to the Contrast Ratio of the point X at Figure in Note (6).

Note 3 : Definition of Response Time (TR, TF)

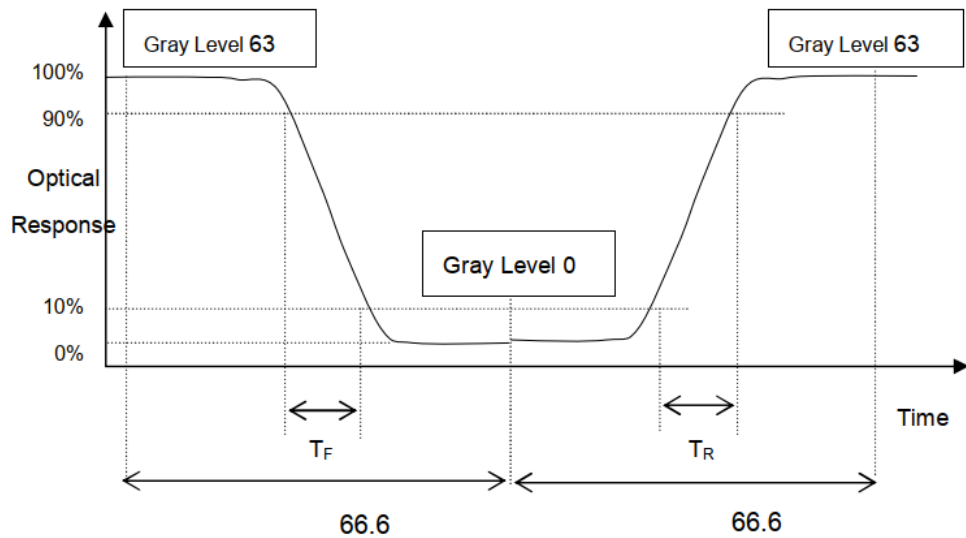

Note 4 : Definition of Luminance of White (L_c)

Measure the luminance of gray level 63 at center point

$$L_c = L(5)$$

$L(x)$ is corresponding to the luminance of the point X at Figure in Note (6).

Note 5 : Measurement Setup

The LCD module should be stabilized at given temperature for 20 minutes to avoid abrupt temperature change during measuring. In order to stabilize the luminance, the measurement should be executed after lighting Backlight for 20 minutes in a windless room.

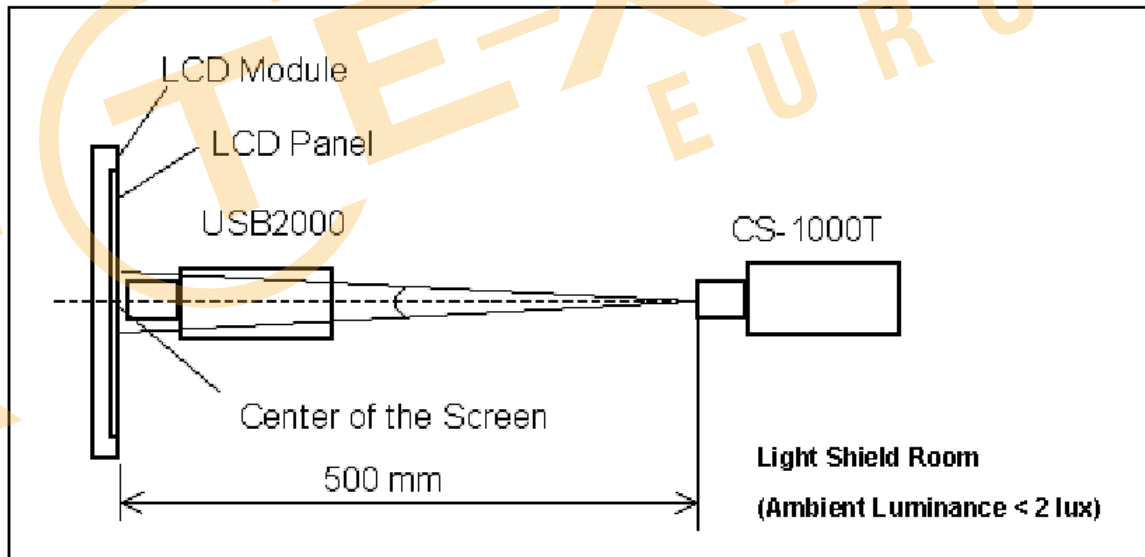

Note 6 : Definition of White Variation

$$\delta W = \frac{\text{Maximum [L (1), L (2), L (3), L (4), L (5)]}}{\text{Minimum [L (1), L (2), L (3), L (4), L (5)]}}$$

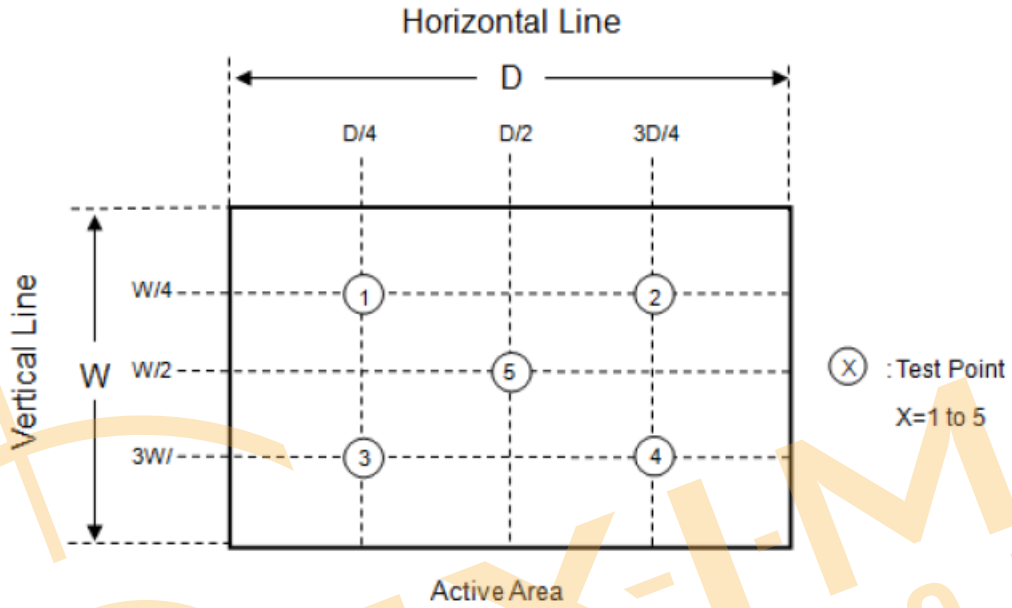

9. TOUCH PANEL SPECIFICATIONS

9.1 Type : USB I/F PCAP

9.2 STRUCTURE :

9.2.1 Thickness : Glass+Glass

9.2.2: Thickness 2.7mm (Cover 1.8t / Sensor 0.7t / COF 0.2)

9.3 IC MODEL :

9.3.1 IC manufacture : EETI

9.3.2 IC part number : EXC81W46

9.3.3 Interface : USB

9.4 ELECTRICAL CHARACTERISTICS :

9.4.1 Operating Voltage : +5V

9.5 MECHANICAL CHARACTERISTICS :

9.5.1 Surface hardness : $\geq 6H$

9.6 OPTICAL CHARACTERISTICS:

9.6.1 Transparency : $\geq 85\%$

9.6.2 Haze:TBD

10. TIMING SPECIFICATIONS

10.1 Power On/Off Sequence

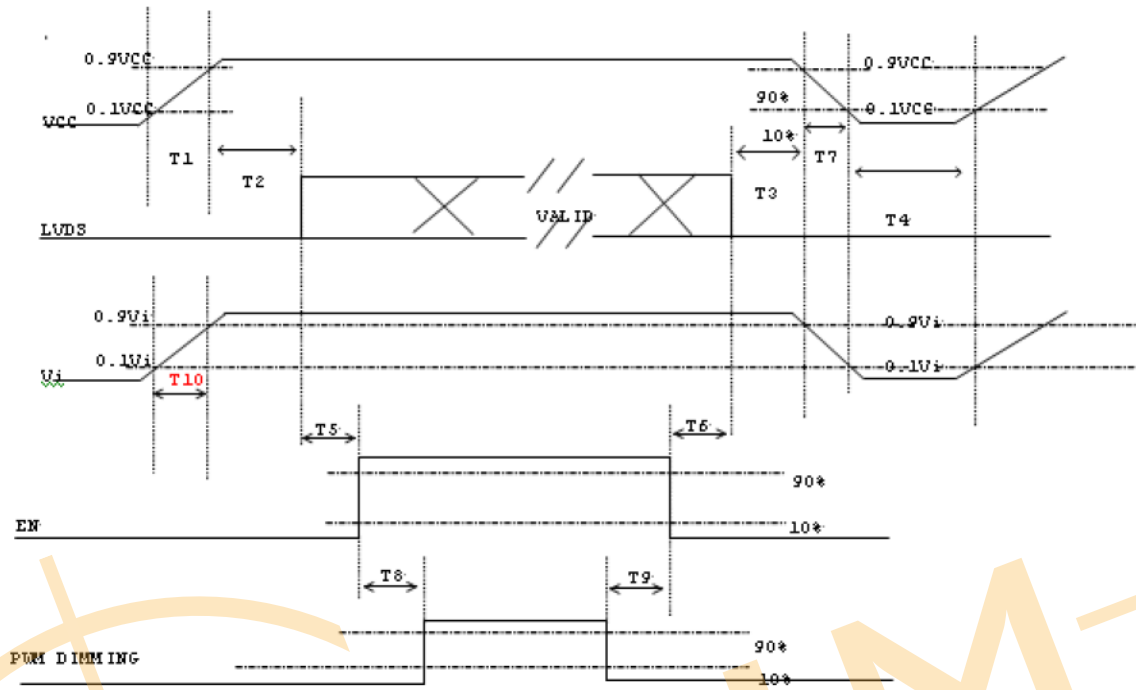

Power ON/OFF Sequence Timing

Parameter	Value			Unit	Note
	MIN.	TYP.	MAX.		
T1	0.5	-	10	ms	
T2	0	-	50	ms	
T3	0	-	50	ms	
T4	500	-	-	ms	
T5	200	-	-	ms	
T6	20	-	-	ms	
T7	5	-	300	ms	
T8	10	-	-	ms	
T9	10	-	-	ms	
T10	20	-	-	ms	

10.2 Input Signal Timing Specifications

Signal	Item	Symbol	Min.	Typ.	Max.	Unit	Note
DCLK	Frequency	Fc	67.45	71	74.55	MHz	
DE	Vertical Total Time	Tv	810	823	1000	Th	(3)
	Vertical Addressing Time	Tvd	800	800	800	Th	
	Horizontal Total Time	Th	1360	1440	1600	Tc	
	Horizontal Addressing Time	Thd	1280	1280	1280	Tc	

Note 1 : Because this module is operated by DE only mode, Hsync and Vsync input signals should be set to low logic level or ground. Otherwise, this module would operate abnormally.

Note 2 : Frame rate is 60Hz

Note 2 : The Tv must be integer, otherwise, the module would operate abnormally.

INPUT SIGNAL TIMING DIAGRAM

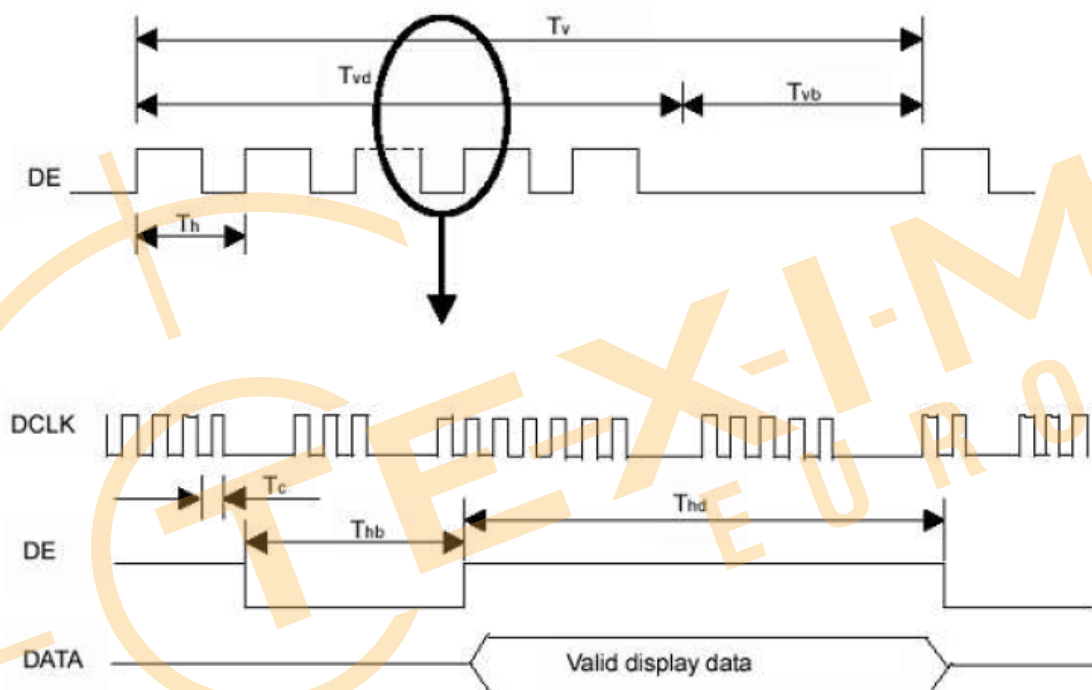

10.3 Input Data Format

SEL 6/8="Low" or "NC" for 6 Bits LVDS

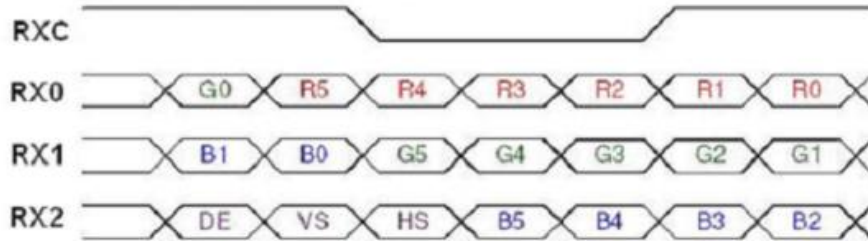

SEL 6/8="High" for 8 Bits LVDS

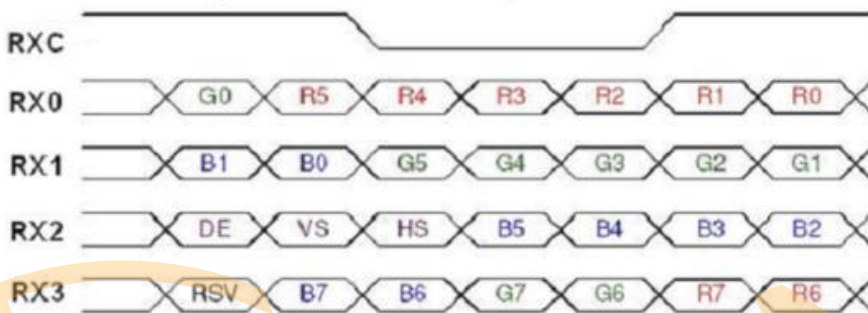

Note (1) R/G/B data 7: MSB, R/G/B data 0: LSB

Note (2) Please follow PSWG

Signal Name	Description	Remark
R7	Red Data 7 (MSB)	Red-pixel Data Each red pixel's brightness data consists of these 8 bits pixel data.
R6	Red Data 6	
R5	Red Data 5	
R4	Red Data 4	
R3	Red Data 3	
R2	Red Data 2	
R1	Red Data 1	
R0	Red Data 0 (LSB)	
G7	Green Data 7 (MSB)	Green-pixel Data Each green pixel's brightness data consists of these 8 bits pixel data.
G6	GreenData 6	
G5	GreenData 5	
G4	GreenData 4	
G3	GreenData 3	
G2	GreenData 2	
G1	GreenData 1	
G0	GreenData 0 (LSB)	
B7	Blue Data 7 (MSB)	Blue-pixel Data Each blue pixel's brightness data consists of these 8 bits pixel data.
B6	Blue Data 6	
B5	Blue Data 5	
B4	Blue Data 4	
B3	Blue Data 3	
B2	Blue Data 2	
B1	Blue Data 1	
B0	Blue Data 0 (LSB)	
RXCLKIN+ RXCLKIN-	LVDS Clock Input	
DE	Display Enable	
VS	Vertical Sync	
HS	Horizontal Sync	

11. RELIABILITY TEST

ENVIRONMENTAL TEST				
NO.	ITEM	CONDITIONS	TIME PERIOD	REMARK
1	High Temperature Storage	Ta= 70°C	240HRS	Note 1,3
2	Low Temperature Storage	Ta= -20°C	240HRS	Note 1,3
3	High Temperature Humidity Storage	60°C,90%RH	240HRS	Note 1,3
4	High Temperature Operation	Ts= 80°C	240HRS	Note 2,3
5	Low Temperature Operation	Ta= -20°C	240HRS	Note 1,3
6	Temperature Cycle	-20°C->70°C (30min) (30min)	100 CYCLE	Note 2,4

In the standard condition, there shall be no practical problem that may affect the display function. After the reliability test, the product only guarantees operation, but don't guarantee all of the cosmetic specification.

Note 1 : Ta is the ambient temperature of samples.

Note 2 : Ts is the temperature of panel's surface.

Note 3 : Before cosmetic and function test, the product must have enough recovery time, at least 2 hours at room temperature.

Note 4 : Star with cold temperature and end with high temperature.

12. PRECAUTIONS FOR USE

12.1 SAFETY

- (1) Do not swallow any liquid crystal, even if there is no proof that liquid crystal is poisonous.
- (2) If the LCD panel breaks, be careful not to get liquid crystal to touch your skin.
- (3) If skin is exposed to liquid crystal, wash the area thoroughly with alcohol or soap.

12.2 STORAGE CONDITIONS

- (1) Store the panel or module in a dark place where the temperature is $23\pm 5^{\circ}\text{C}$ and the humidity is below $50\pm 20\% \text{RH}$.
- (2) Store in anti-static electricity container.
- (3) Store in clean environment, free from dust, active gas, and solvent.
- (4) Do not place the module near organics solvents or corrosive gases.
- (5) Do not crush, shake, or jolt the module.

12.3 HANDLING PRECAUTIONS

- (1) Avoid static electricity which can damage the CMOS LSI.
- (2) The polarizing plate of the display is very fragile. So, please handle it very carefully.
- (3) Do not give external shock.
- (4) Do not apply excessive force on the surface.
- (5) Do not wipe the polarizing plate with a dry cloth, as it may easily scratch the Surface of plate.
- (6) Do not use ketonic solvent & Aromatic solvent, use with a soft cloth soaked with a cleaning naphtha solvent.
- (7) Do not operate it above the absolute maximum rating.
- (8) Do not remove the panel or frame from the module.
- (9) When the module is assembled, it should be attached to the system firmly, Be careful not to twist and bend the module.
- (10) Wipe off water droplets or oil immediately . If you leave the droplets for a long time, staining and discoloration may occur.
- (11) If the liquid crystal material leaks from the panel, it should be kept away from the eyes or mouth. In case of contact with hands, legs or clothes, it must be washed away thoroughly with soap.

12.4 WARRANTY

- (1) Acceptance inspection period. The period is within one month after the arrival of contracted commodity at the buyer's factory site.
- (2) Applicable warrant period. The period is within 12 months since the date of shipping out under normal using and storage conditions.

Disclaimer

ALL PRODUCTS, PRODUCT SPECIFICATIONS AND DATA ARE SUBJECT TO CHANGE WITHOUT NOTICE TO IMPROVE RELIABILITY, FUNCTION OR DESIGN OR OTHERWISE.

Texim Europe B.V. its affiliates, agents, and employees, and all persons acting on its or their behalf (collectively, "Texim"), disclaim any and all liability for any errors, inaccuracies or incompleteness contained in any datasheet or in any other disclosure relating to any product.

Texim makes no warranty, representation or guarantee regarding the suitability of the products for any particular purpose or the continuing production of any product.

It is the customer's responsibility to validate that a particular product with the properties described in the product specification is suitable for use in a particular application.

Parameters provided in datasheets and / or specifications may vary in different applications and performance may vary over time.

All operating parameters, including typical parameters, must be validated for each customer application by the customer's technical experts.

Please contact us if you have any questions about the contents of the datasheet.

This may not be the latest version of the datasheet. Please check with us if a later version is available.

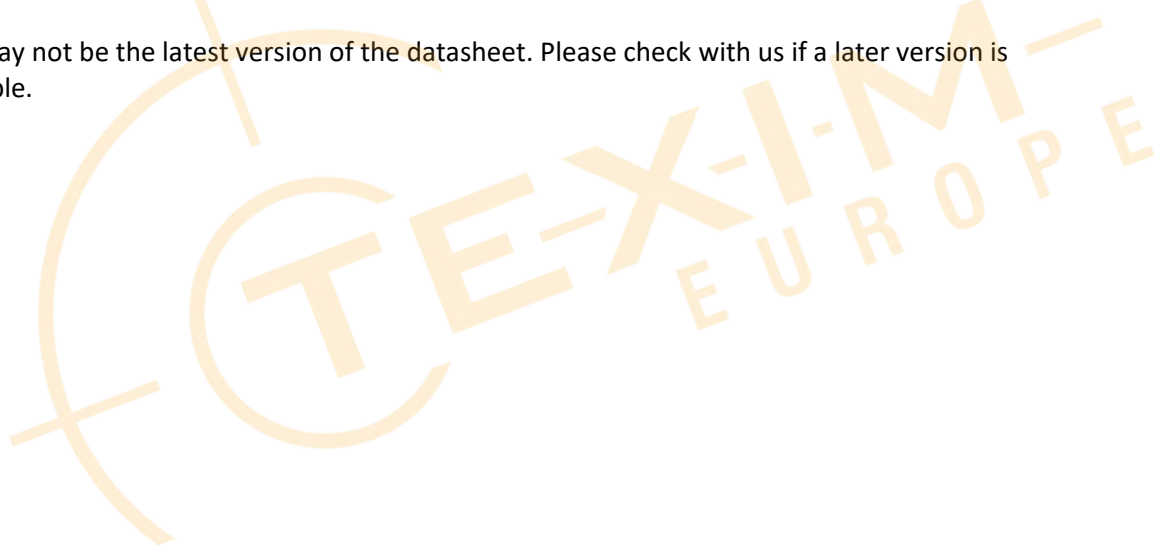



Headquarters & Warehouse

Elektrostraat 17
 NL-7483 PG Haaksbergen
 The Netherlands

T: +31 (0)53 573 33 33
 E: info@texim-europe.com
 Homepage: www.texim-europe.com



The Netherlands

Elektrostraat 17
 NL-7483 PG Haaksbergen

T: +31 (0)53 573 33 33
 E: nl@texim-europe.com



Belgium

Zuiderlaan 14, box 10
 B-1731 Zellik

T: +32 (0)2 462 01 00
 E: belgium@texim-europe.com



UK & Ireland

St Mary's House, Church Lane
 Carlton Le Moorland
 Lincoln LN5 9HS

T: +44 (0)1522 789 555
 E: uk@texim-europe.com



Germany

Bahnhofstrasse 92
 D-25451 Quickborn

T: +49 (0)4106 627 07-0
 E: germany@texim-europe.com



Germany

Martin-Kollar-Strasse 9
 D-81829 München

T: +49 (0)89 436 086-0
 E: muenchen@texim-europe.com



Austria

Martin-Kollar-Strasse 9
 D-81829 München

T: +49 (0)89 436 086-0
 E: austria@texim-europe.com



Nordic

Stockholmsgade 45
 2100 Copenhagen

T: +45 88 20 26 30
 E: nordic@texim-europe.com



Italy

Martin-Kollar-Strasse 9
 D-81829 München

T: +49 (0)89 436 086-0
 E: italy@texim-europe.com