

Chefree Technology Corp.

TFT COLOR LCD MODULE

MODEL: CF050KLDLWH-CA1

(Complied with RoHS)

WVGA
LVDS interface

Version: P01

Customer : _____

Approved By : _____

Date: _____

CHEFREE		
APPROVAL	CHECKER	PREPARE
Tim	Mark	Benson

C O N T E N T S

1. RECORD OF REVISION.....	1
2. MECHANICAL SPECIFICATIONS	2
3. OUTLINE DIMENSIONS	3
4. INTERFACE PIN CONNECTION	4
5. BLOCK DIAGRAM.....	6
6. ABSOLUTE MAXIMUM RATINGS	7
7. ELECTRICAL CHARACTERISTICS.....	8
8. OPTICAL CHARACTERISTICS.....	10
9. TOUCH PANEL SPECIFICATIONS	12
10. TIMING SPECIFICATIONS	13
11. RELIABILITY TEST	16
12. PRECAUTIONS FOR USE.....	17



1. RECORD OF REVISION

Rev	DATE	PAGE	SUMMARY
P00	2022.03.25	ALL	Preliminary specification was first issued.
P01	2022.05.11	7,8,15	1. Updated the Power current (IDD: TBD→100mA; ILED: 0.5A →0.45A) 2. Add LVDS Input Pin Mapping Table (JEIDA only)

2. MECHANICAL SPECIFICATIONS

(1)	Number of Dots	800(R.G.B) x 480
(2)	Module Size(mm)	134.60(H) x 91.40(V) x 9.07 (D)
(3)	Active Area(mm)	108(H) x 64.80(V)
(4)	Pixel Pitch(mm)	0.135(H) x 0.135(V)
(5)	LCD Model	Normally Black
(6)	Backlight Color	White, LED
(7)	Viewing Direction	ALL direction
(8)	Electrical Interface	LVDS
(9)	Color Configuration	R.G.B Stripe
(10)	Touch Panel Mode	Built – in EETI 81W46 Controller
(11)	Module Weight(g)	TBD

3. OUTLINE DIMENSIONS

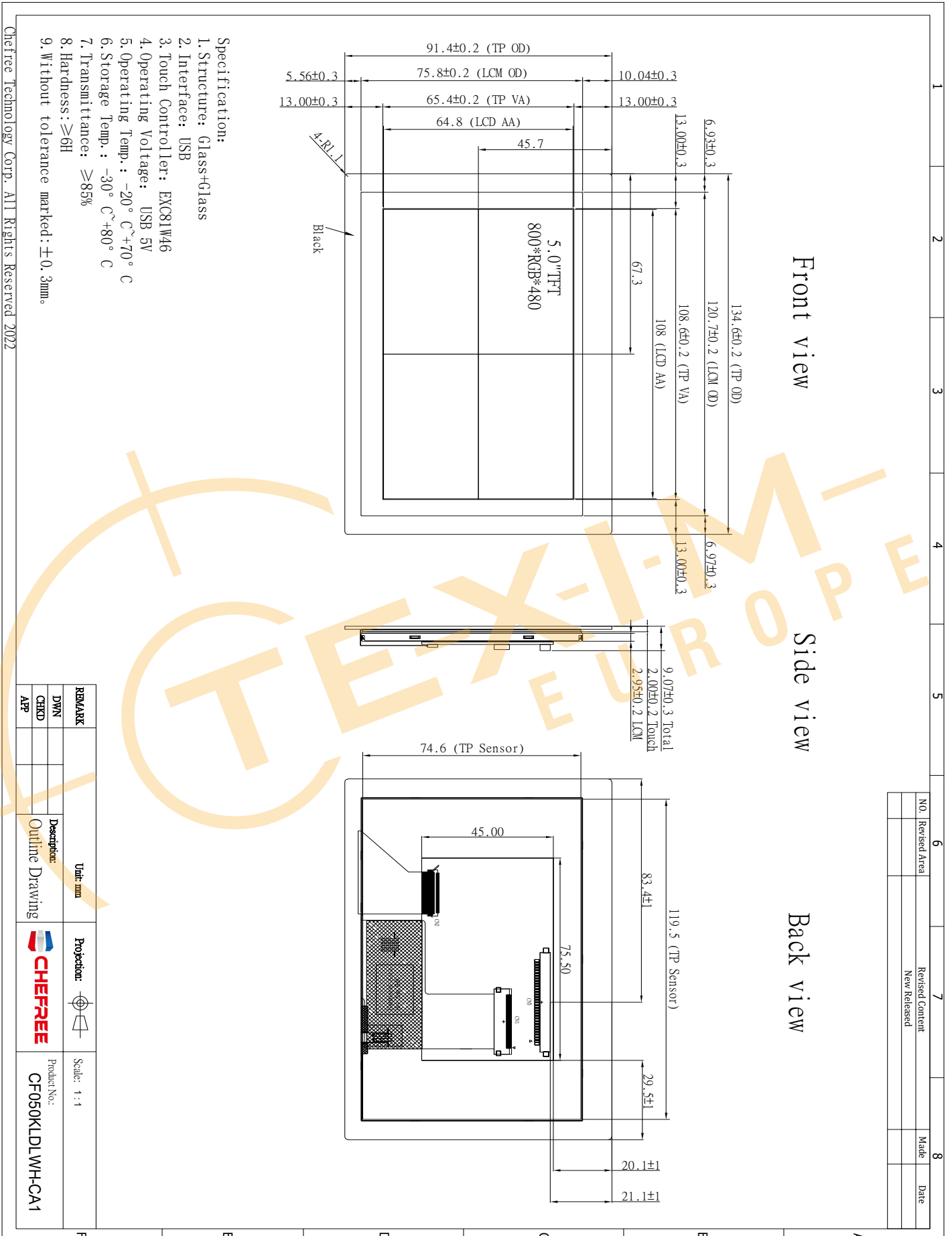

Chefree Technology Corp. All Rights Reserved 2022

4. INTERFACE PIN CONNECTION

4.1 TFT LCM PANEL PIN DEFINE

CN1 Connector : STM MSBK2407P30 RF:HB or Equivalent

PIN NO.	Definition	I/O	Description	Remark
1	GND	P	Ground	
2	GND	P	Ground	
3	EN	I	Enable Control for Backlight	
4	PWM	I	Brightness Control for Backlight	
5	VLED	P	Power Supply for LED Backlight	
6	VLED	P	Power Supply for LED Backlight	
7	VDD	P	Power Supply for Digital Circuit (3.3V)	
8	R/L	I	Horizontal inversion H:from left to right (default) L:from right to left	
9	U/D	I	Vertical inversion H:from up to down(default) L:from down to up	
10	GND	P	Ground	
11	RxIN0-	I	Negative LVDS Differential Data Input	
12	RxIN0+	I	Positive LVDS Differential Data Input	
13	GND	P	Ground	
14	RxIN1-	I	Negative LVDS Differential Data Input	
15	RxIN1+	I	Positive LVDS Differential Data Input	
16	GND	P	Ground	
17	RxIN2-	I	Negative LVDS Differential Data Input	
18	RxIN2+	I	Positive LVDS Differential Data Input	
19	GND	P	Ground	
20	RxCLK-	I	Negative LVDS Differential Clock Input	
21	RxCLK+	I	Positive LVDS Differential Clock Input	
22	GND	P	Ground	
23	RxIN3-	I	Negative LVDS Differential Data Input	
24	RxIN3+	I	Positive LVDS Differential Data Input	
25	NC	-	No connection	
26	NC	-	No connection	
27	VCC	P	Power Supply for PCAP(5V)	
28	D-	I	Data-	
29	D+	I	Data+	
30	GND	P	Ground	

Note : 'P' stand for Power, 'I' stand for Input

5. BLOCK DIAGRAM

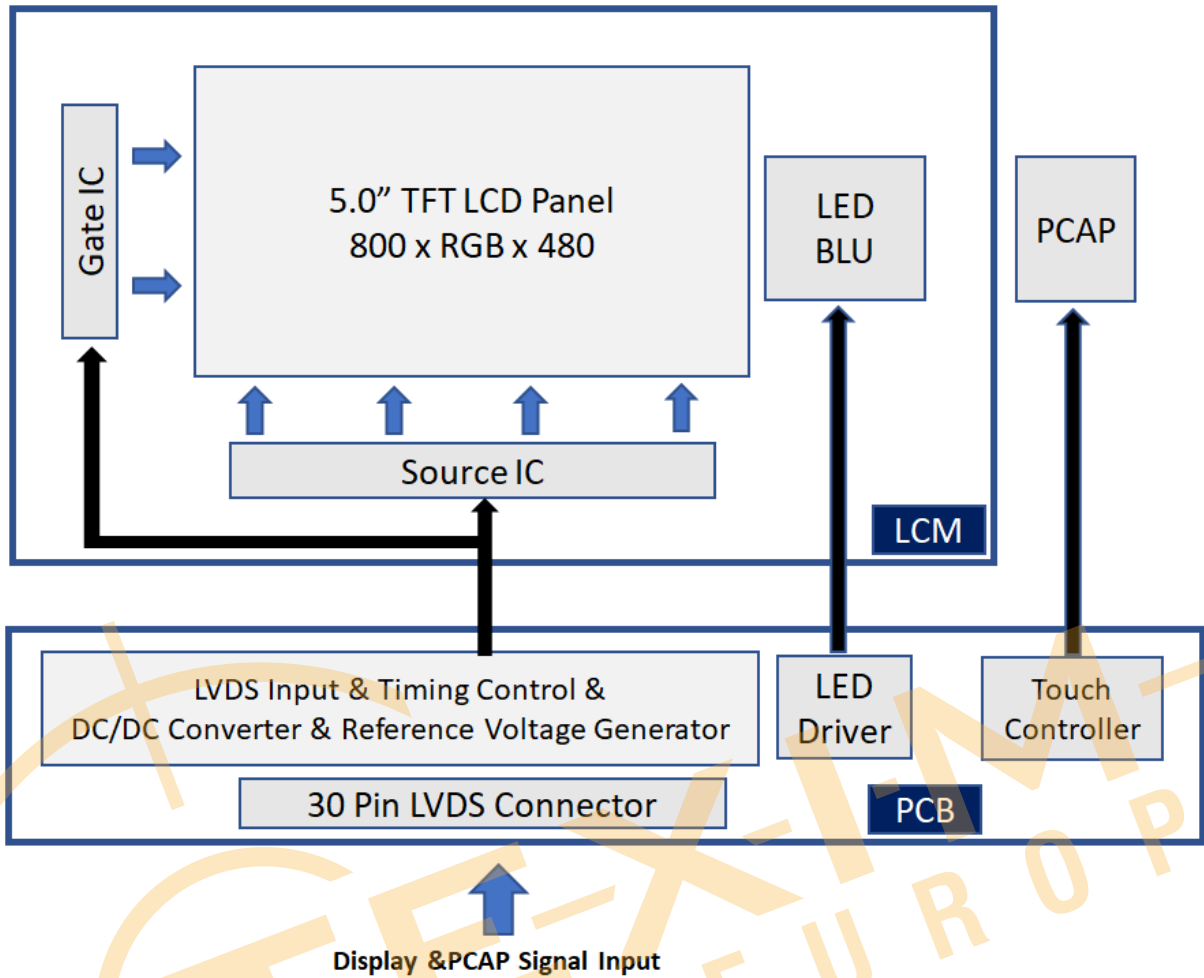

6. ABSOLUTE MAXIMUM RATINGS

6.1 ELECTRICAL ABSOLUTE MAXIMUM RATINGS

ITEM	SYMBOL	MIN.	MAX.	UNIT	REMARK
Power Supply Voltage	VDD	-0.5	5	V	
Power Voltage For CTP	VCC	-	-	V	

Note : The absolute maximum rating values of this product not allowed to be exceeded at any times. Should be module be used with any of absolute maximum ratings exceeded. The characteristics of the module may not be recovered, or in an extreme case, the module may be permanently destroyed.

6.2 ENVIRONMENTAL ABSOLUTE MAXIMUM RATINGS

ITEM	OPERATING		STORAGE		REMARK
	MIN.	MAX.	MIN.	MAX.	
Ambient Temperature(°C)	-20	70	-30	80	Note 1,2
Humidity(% RH)	10~90(Note3)		10~90(Note 3)		-

Note 1 : The response time will become lower when operated at low temperature.

Note 2 : Background color changes slightly depending on ambient temperature.

Note 3 : Storage Ta=40°C & RH=90% ≤ 96Hrs



7. ELECTRICAL CHARACTERISTICS

7.1 ELECTRICAL CHARACTERISTICS

Ta=25°C

ITEM	SYMBOL	MIN.	TYP.	MAX.	UNIT	REMARK
Supply Voltage	VDD	3.0	3.3	3.6	V	
Supply Current	IDD	-	100	-	mA	Note 1

Note1: Test Condition: VDD=3.3V ; Test Pattern: White



7.2 BACKLIGHT UNITS

Ta=25°C

ITEM	SYMBOL	MIN.	TYP.	MAX.	UNIT	REMARK
Backlight Supply Voltage	VLED	-	5	-	V	
Backlight Supply Current	ILED	-	0.45	-	A	
LED Life Time	-	-	30,000	-	Hrs	

Note 1: Optical performance should be evaluated at Ta=25°C only.

Note 2: If LED is driven by high current, high ambient temperature & humidity condition. The life Time of LED will be reduced. Operating life means brightness goes down to 50% initial brightness. Typical operating life time is estimated data.

7.3 CTP ELECTRICAL CHARACTERISTICS

ITEM	SYMBOL	MIN.	TYP.	MAX.	UNIT	REMARK
Power Voltage For PCAP	VCC	-	5.0	-	V	



8. OPTICAL CHARACTERISTICS

Ta=25°C

ITEM	SYMBOL	CONDITIONS	MIN.	TYP.	MAX.	UNIT	REMARK
Contrast Ratio	CR	-	800	1000	-	-	Note 1
Response Time	TR+TF	-	-	30	40	ms	Note 4
Chromaticity	White	Wx	0.290	0.340	0.390	-	Note 5
		Wy	0.311	0.361	0.411	-	
	Red	Rx	0.565	0.615	0.665	-	
		Ry	0.286	0.336	0.386	-	
	Green	Gx	0.342	0.392	0.442	-	
		Gy	0.502	0.552	0.602	-	
	Blue	Bx	0.090	0.140	0.190	-	
		By	0.075	0.125	0.175	-	
Viewing Angle	Hor.	θ_T	-	80	-	Deg.	Note 6
		θ_B	-	80	-		
	Ver.	θ_L	-	80	-		
		θ_R	-	80	-		
NTSC	-	$\theta_x=\theta_y=0^\circ$	45	50	-	%	Note 5
Luminance	LV	$\theta_x=\theta_y=0^\circ$	800	900	-	cd/m ²	Note 2
Luminance Uniformity	YU	$\theta_x=\theta_y=0^\circ$	-	70	-	%	Note 3

Note 1 : Definition of Contrast Ratio (CR) :

Contrast ratio is defined mathematically by the following formula. For more information see FIG.2.

$$\text{Contrast ratio (CR)} = \frac{\text{Luminance with all pixels white}}{\text{Luminance with all pixels black}}$$

For contrast ratio, Surface Luminance, Luminance uniformity and CIE, the testing data is based on TOPCON's BM-5 or BM-7 photo detector or compatible.

Note 2 : Definition of surface luminance

Surface luminance is the luminance with pixels displaying white. For more information see FIG.2.

$$L_v = \text{Average Surface Luminance with all white pixels}(P_1, P_2, P_3, \dots, P_n)$$

Note 3 : Definition of luminance uniformity

The luminance uniformity in surface luminance is determined by measuring luminance at each test position 1 through n, and then dividing the maximum luminance of n points luminance by minimum luminance of n points luminance. For more information see FIG.2.

$$YU = \frac{\text{Minimum surface luminance with all white pixels}(P_1, P_2, P_3, \dots, P_n)}{\text{Maximum surface luminance with all white pixels}(P_1, P_2, P_3, \dots, P_n)}$$

Note 4 : Definition of response time

The response time is defined as the LCD optical switching time interval between “white” state and “Black” state. Rise time(T_r) is the time between photo detector output intensity changed from 90% to 10%. And fall time (T_f) is the time between photo detector output intensity changed from 10% to 90%. For additional information see FIG.1.

Note 5 : Definition of color chromaticity (CIE1931)

CIE (x,y) chromaticity, The x,y value is determined by screen active area center position P5. For more information see FIG.2.

Note 6 : Definition of viewing angle

Viewing angle is the angle at which the contrast ratio is greater than 10. Angles are determined for the horizontal or x axis and the vertical or y axis with respect to the z axis which is normal to the LCD surface. For more information see FIG.3.

For viewing angle and response time testing, the testing data is base on Autronic-Melchers’s ConoScope or DMS series instruments or compatible.

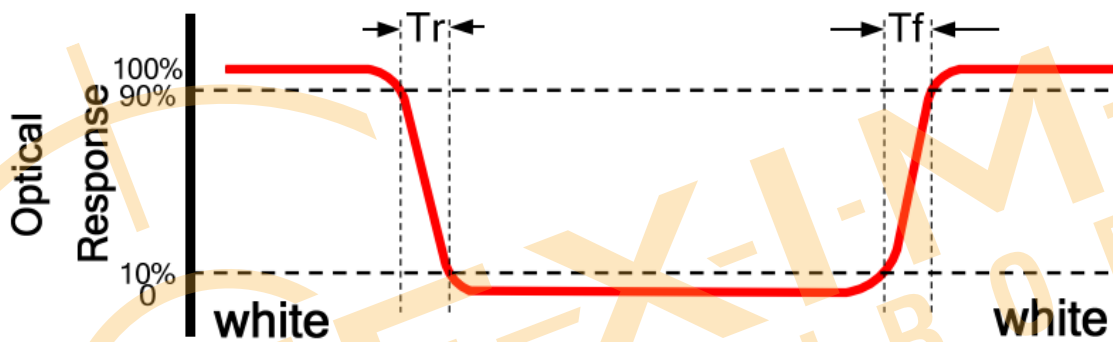

FIG.2 Measuring method for contrast ratio, surface luminance, luminance uniformity, CIE (x,y) chromaticity
 Size : $S \leq 5"$ (See Figure a) A: 5 mm B: 5mm
 H,V : Active area
 Light spot size $\Phi = 5\text{mm}$ (BM-5) or $\Phi = 7.7\text{mm}$ (BM-7) 50cm distance or compatible distance from the LCD surface to detector lens.
 Test spot position : see Figure a.
 Measurement instrument : TOPCON’ s luminance meter BM-5 or BM7 or compatible (see Figure c).

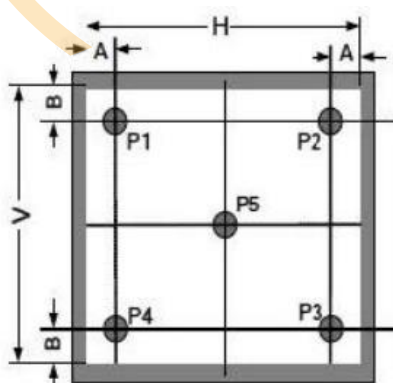

Figure a

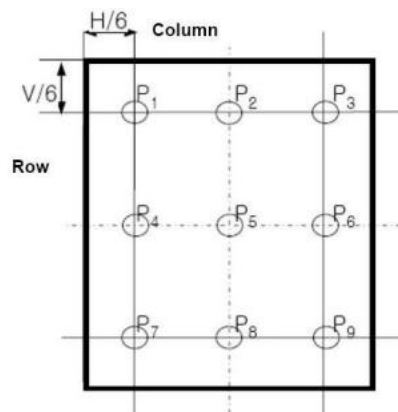

Figure b

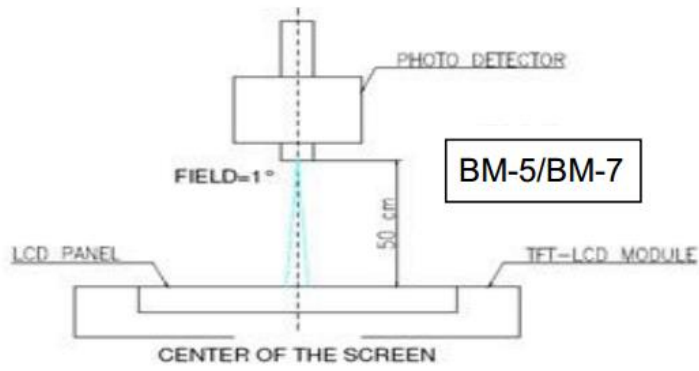
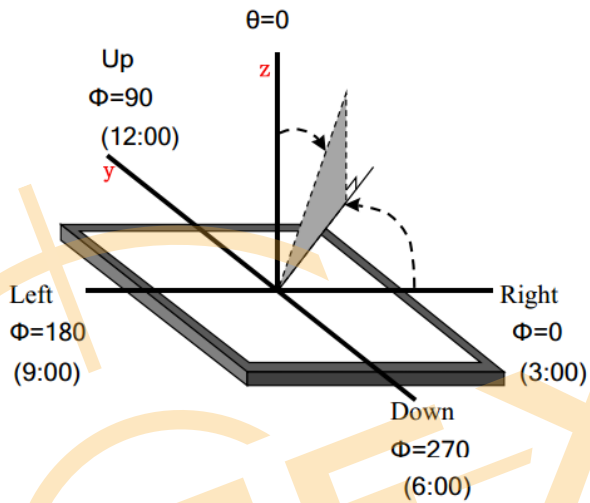

Figure c

FIG.3 The definition of viewing angle



9. TOUCH PANEL SPECIFICATIONS

9.1 Type :

9.1.1 Glass+Glass

9.2 STRUCTURE :

9.2.1 Thickness : 2.0±0.2mm

9.2.2 Thickness : 2.0mm (Cover 1.1t / Sensor 0.7t / COF 0.2)

9.3 IC MODEL :

9.3.1 IC manufacture : EETI

9.3.2 IC part number : EXC81W46

9.3.3 Interface : USB

9.4 ELECTRICAL CHARACTERISTICS :

9.4.1 Operating Voltage : +5V

9.5 MECHANICAL CHARACTERISTICS :

9.5.1 Surface hardness : 6H

9.6 OPTICAL CHARACTERISTICS :

9.6.1 Transparency : $\geq 85\%$

9.6.2 Haze:TBD

10. TIMING SPECIFICATIONS

10.1 Interface Timing

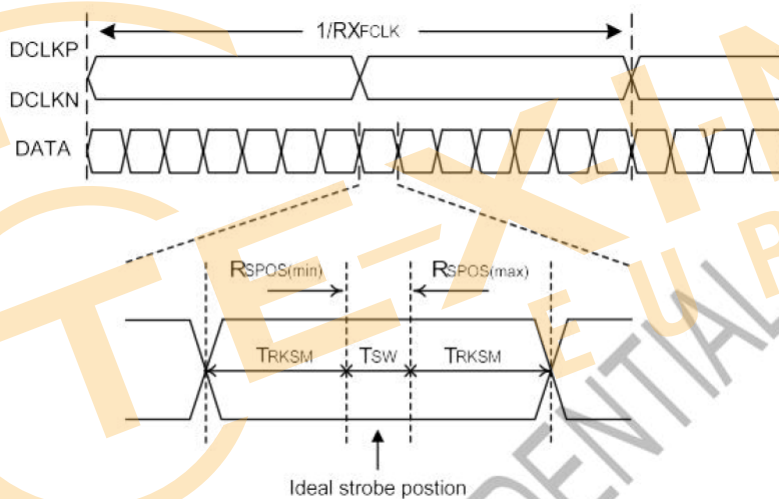
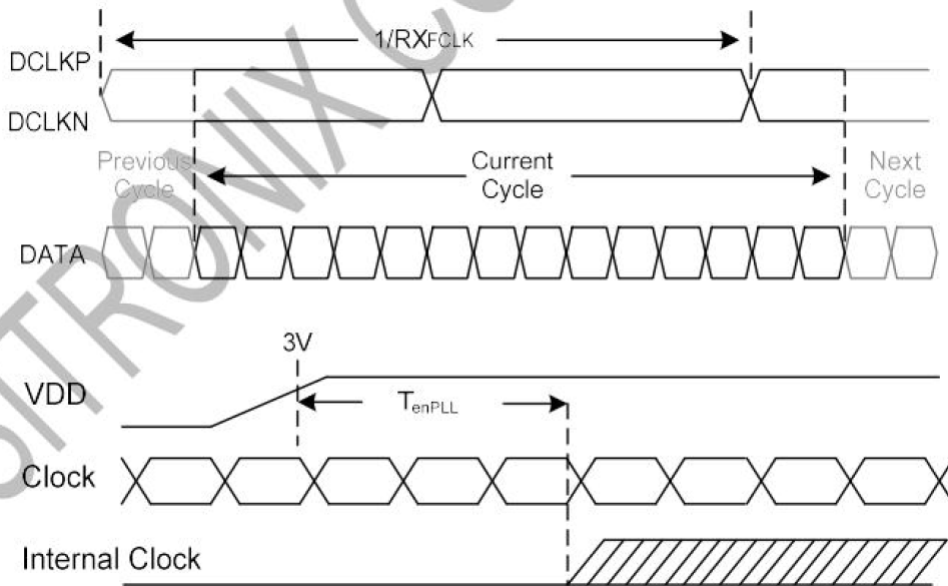

RRKSM: Receiver strobe margin
 RSPOS: Receiver strobe position
 Tsw: Strobe width (internal DATA sampling window)

Item	Symbol	Min.	Typ.	Max.	Unit	Note
Clock Frequency	RXFCLK	23	25	27	MHz	
Input Data Skew Margin	TRSKM	400	-	-	ps	
Clock High Time	TLVCH	4/(7 x RXFCLK)			ns	
Clock Low Time	TLVCL	3/(7 x RXFCLK)			ns	
PLL Wake-up Time	TenPLL	-	-	150	us	
LVDS Spread Spectrum Clocking (SSC) Tolerance of LVDS Receiver						
Modulation Frequency	SSCMF	-	-	100	KHz	
Modulation Rate	SSCMR	-	-	+/-3	%	

10.2 Power On Sequence

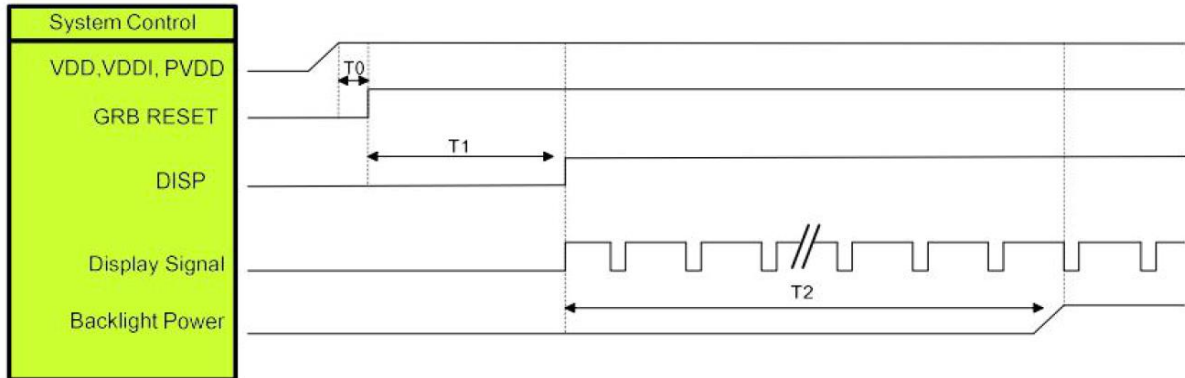

SYMBOL	DESCRIPTION	MIN. Time	UNIT
T0	System power stability to GRB RESET signal	0	ms
T1	GRB RESET="High" to DISP="High"	10	ms
T2	Display Signal output to Backlight Power on	250	ms

10.3 Power Off Sequence

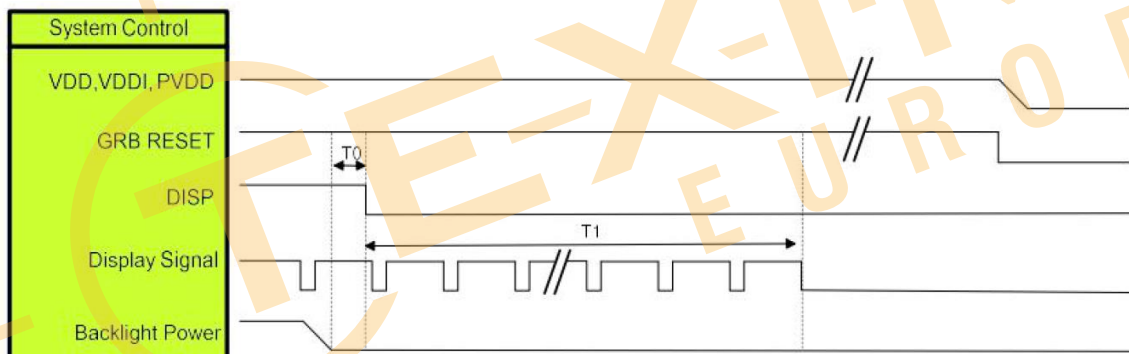

SYMBOL	DESCRIPTION	MIN. Time	UNIT
T0	Backlight Power off to DISP="Low"	5	ms
T1	DISP="Low" to IC internal voltage discharge complete	80	ms

10.4 LVDS Input Pin Mapping Table

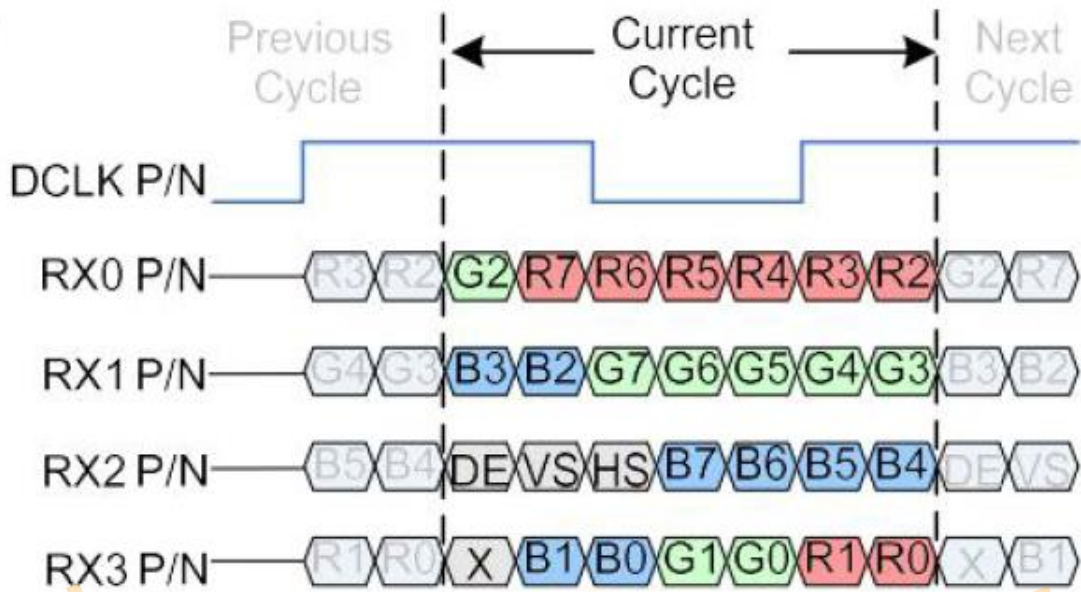

4 Lane JEIDA Data Format Color Bit Map

11. RELIABILITY TEST

ENVIRONMENTAL TEST				
NO.	ITEM	CONDITIONS	TIME PERIOD	REMARK
1	High Temperature Storage	Ta= 80°C	96Hours	Note 1,3
2	Low Temperature Storage	Ta= -30°C	96Hours	Note 1,3
3	High Temperature Humidity Storage	60°C,90%RH	96Hours	Note 1,3
4	High Temperature Operation	Ts= 70°C	96Hours	Note 2,3
5	Low Temperature Operation	Ta= -20°C	96Hours	Note 1,3
6	Temperature Cycle	-20°C~+60°C	1H/cycle 30CYCLE	Note 2,4

In the standard condition, there shall be no practical problem that may affect the display function. After the reliability test, the product only guarantees operation, but don't guarantee all of the cosmetic specification.

Note 1 : Ta is the ambient temperature of samples.

Note 2 : Ts is the temperature of panel's surface.

Note 3 : Before cosmetic and function test, the product must have enough recovery time, at least 2 hours at room temperature.

Note 4 : Star with cold temperature and end with high temperature.

12. PRECAUTIONS FOR USE

12.1 SAFETY

- (1) Do not swallow any liquid crystal, even if there is no proof that liquid crystal is poisonous.
- (2) If the LCD panel breaks, be careful not to get liquid crystal to touch your skin.
- (3) If skin is exposed to liquid crystal, wash the area thoroughly with alcohol or soap.

12.2 STORAGE CONDITIONS

- (1) Store the panel or module in a dark place where the temperature is $23\pm 5^{\circ}\text{C}$ and the humidity is below $50\pm 20\%\text{RH}$.
- (2) Store in anti-static electricity container.
- (3) Store in clean environment, free from dust, active gas, and solvent.
- (4) Do not place the module near organics solvents or corrosive gases.
- (5) Do not crush, shake, or jolt the module.

12.3 HANDLING PRECAUTIONS

- (1) Avoid static electricity which can damage the CMOS LSI.
- (2) The polarizing plate of the display is very fragile. So, please handle it very carefully.
- (3) Do not give external shock.
- (4) Do not apply excessive force on the surface.
- (5) Do not wipe the polarizing plate with a dry cloth, as it may easily scratch the Surface of plate.
- (6) Do not use ketonic solvent & Aromatic solvent, use with a soft cloth soaked with a cleaning naphtha solvent.
- (7) Do not operate it above the absolute maximum rating.
- (8) Do not remove the panel or frame from the module.
- (9) When the module is assembled, it should be attached to the system firmly, Be careful not to twist and bend the module.
- (10) Wipe off water droplets or oil immediately . If you leave the droplets for a long time, staining and discoloration may occur.
- (11) If the liquid crystal material leaks from the panel, it should be kept away from the eyes or mouth. In case of contact with hands, legs or clothes, it must be washed away thoroughly with soap.

12.4 WARRANTY

- (1) Acceptance inspection period. The period is within one month after the arrival of contracted commodity at the buyer's factory site.
- (2) Applicable warrant period. The period is within 12 months since the date of shipping out under normal using and storage conditions.

Disclaimer

ALL PRODUCTS, PRODUCT SPECIFICATIONS AND DATA ARE SUBJECT TO CHANGE WITHOUT NOTICE TO IMPROVE RELIABILITY, FUNCTION OR DESIGN OR OTHERWISE.

Texim Europe B.V. its affiliates, agents, and employees, and all persons acting on its or their behalf (collectively, "Texim"), disclaim any and all liability for any errors, inaccuracies or incompleteness contained in any datasheet or in any other disclosure relating to any product.

Texim makes no warranty, representation or guarantee regarding the suitability of the products for any particular purpose or the continuing production of any product.

It is the customer's responsibility to validate that a particular product with the properties described in the product specification is suitable for use in a particular application.

Parameters provided in datasheets and / or specifications may vary in different applications and performance may vary over time.

All operating parameters, including typical parameters, must be validated for each customer application by the customer's technical experts.

Please contact us if you have any questions about the contents of the datasheet.

This may not be the latest version of the datasheet. Please check with us if a later version is available.

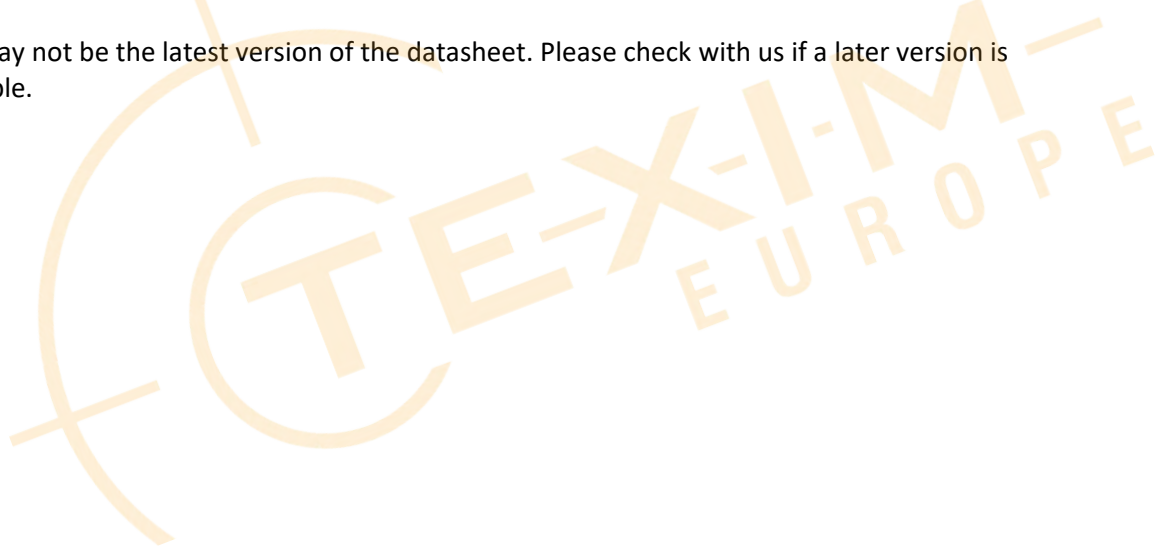



Headquarters & Warehouse

Elektrostraat 17
 NL-7483 PG Haaksbergen
 The Netherlands

T: +31 (0)53 573 33 33
 E: info@texim-europe.com
 Homepage: www.texim-europe.com



The Netherlands

Elektrostraat 17
 NL-7483 PG Haaksbergen

T: +31 (0)53 573 33 33
 E: nl@texim-europe.com



Belgium

Zuiderlaan 14, box 10
 B-1731 Zellik

T: +32 (0)2 462 01 00
 E: belgium@texim-europe.com



UK & Ireland

St Mary's House, Church Lane
 Carlton Le Moorland
 Lincoln LN5 9HS

T: +44 (0)1522 789 555
 E: uk@texim-europe.com



Germany

Bahnhofstrasse 92
 D-25451 Quickborn

T: +49 (0)4106 627 07-0
 E: germany@texim-europe.com



Germany

Martin-Kollar-Strasse 9
 D-81829 München

T: +49 (0)89 436 086-0
 E: muenchen@texim-europe.com



Austria

Martin-Kollar-Strasse 9
 D-81829 München

T: +49 (0)89 436 086-0
 E: austria@texim-europe.com



Nordic

Stockholmsgade 45
 2100 Copenhagen

T: +45 88 20 26 30
 E: nordic@texim-europe.com



Italy

Martin-Kollar-Strasse 9
 D-81829 München

T: +49 (0)89 436 086-0
 E: italy@texim-europe.com