

TFT DISPLAY SPECIFICATION

Distributed by:



www.texim-europe.com



WINSTAR Display Co.,Ltd.
華凌光電股份有限公司



Winstar Display Co., LTD

華凌光電股份有限公司



WEB: <https://www.winstar.com.tw> E-mail: sales@winstar.com.tw

SPECIFICATION

CUSTOMER : _____

MODULE NO.: WFN0286A2SOWADNA000

APPROVED BY: (FOR CUSTOMER USE ONLY)	PCB VERSION:	DATA:
	<input type="checkbox"/> TFT Display Inspection Specification: https://www.winstar.com.tw/technology/download.html	<input type="checkbox"/> Precaution in use of TFT module: https://www.winstar.com.tw/technology/download/declaration.html

SALES BY	APPROVED BY	CHECKED BY	PREPARED BY
			葉虹蘭
ISSUED DATE:	2026/04/07		



Winstar Display Co., LTD
 華凌光電股份有限公司

MODLE NO :

RECORDS OF REVISION

DOC. FIRST ISSUE

VERSION	DATE	REVISED PAGE NO.	SUMMARY
0	2025/12/15		First issue
A	2026/01/22		Modify Match connector
B	2026/03/09		Add soldering tape
C	2026/04/07		Add item (With /Without TP)



Contents

1. Module Classification Information
2. Summary
3. General Specifications
4. Absolute Maximum Ratings
5. Electrical Characteristics
6. AC Characteristics
7. Reset Timing
8. Function Description
9. Optical Characteristics
10. Interface
11. Block Diagram
12. Reliability
13. Contour Drawing
14. Initial Code For Reference
15. Other

1. Module Classification Information

W	F	N	0286	A2	S	0W	A	D	N	A	0	00
①	②	③	④	⑤	⑥	⑦	⑧	⑨	⑩	⑪	⑫	⑬

①	Brand : WINSTAR DISPLAY CORPORATION															
②	Display Type : F→TFT Type, J→Custom TFT															
③	N: Normal E : EFD M : MIP															
④	Display Size : 2.86" TFT															
⑤	Model serials no.															
⑥	Backlight Type :	F :	CCFL, White					T :	LED, White							
		S :	LED, High Light White					Z :	Nichia LED, White							
		N :	With out Backlight					A :	Front Light							
⑦	LCD Polarize Type/ Temperature range/ Gray Scale Inversion Direction	Operating Temperature		Normal temperature				Super Wide temperature								
		LCD tape		TN		IPS	VA	TN				IPS	VA			
		View angle		6H	12H	3H		6H	12H	O-Film	OD-Film					
		Reflective		AA	-	-	-	AT	AN	-	-	-	AW	AV		
		Transflective		0B	0E	BN	AC	02	0M	0P	-	-	08	04		
		Transmissive		0C	0F	-	0A	0T	0N	0Q	0R	0S	0W	0V		
		Operating Temperature		Wide temperature												
		LCD tape		TN												
		View angle		6H	12H	2H	3H	9H	O-Film	OD-Film	All View	IPS	VA			
		Reflective		AG	AJ	AB	-	AW	-	-	05	AY	AX			
		Transflective		0H	0K	-	0G	-	0U	-	-	07	03			
		Transmissive		0I	0L	-	-	0W	0Z	0J	-	0Y	0X			
⑧	A :	TFT LCD						G :	TFT+ Screw holes							
	B :	TFT+ Screw holes+ Control board						H :	TFT+ D/V board							
	C :	TFT+ Screw holes + A/D board						I :	TFT+ Screw holes +D/V board							
	D :	TFT+ Screw holes + A/D board + Control board						J :	TFT+ Power board							
	E :	TFT+ Screw holes + Power board						Z :	TFT+ Power board (Embedded)							
	F :	TFT+ Control board														
⑨	A :	Analog			B :	6-bits parallel			D :	Digital			E :	eDP		
	L :	LVDS			M :	MIPI			S :	SPI						
⑩	Interface:															
	A :	8Bit			B :	16Bit			E :	eDP			H :	HDMI		
	M :	MIPI			N :	Without Control board			P :	DP			R :	RS232		
								S :	SPI			U :	USB			
⑪	TS:															
	A :	CTP + Optical bonding				B :	CTP + USB				C :	CTP				
	D :	CTP + USB + Optical bonding				E :	RTP + Optical bonding				F :	CG + Optical bonding				
	H :	CTP + Only G-sensor				J :	CTP + Only G-sensor + USB				L :	CTP+ Hover Touch				
	N :	Without TS				Q :	in-cell				R :	on-cell				
	T :	RTP				U :	CG				V :	in-cell + CG				
	W :	on-cell + CG														
⑫	Version:															
⑬	Serial No.: Serial number (00~99)															

2.Summary

TFT 2.86" is a color active matrix thin film transistor (TFT) liquid crystal display (LCD) that uses amorphous silicon TFT as a switching device. This TFT LCD has a 2.86 inch diagonally measured active display area with 376x960 (376 horizontal by 960 vertical pixel) resolution.



3. General Specifications

Item	Dimension	Unit
Size	2.86"	inch
Dot Matrix	376 x RGB x 960 (TFT)	dots
Module dimension	40.2 (W) x 84.3 (H) x 3.85 (D)	mm
Active area	26.508 x 67.68	mm
Pixel Pitch	0.0705 x 0.0705	mm
LCD type	TFT, Normally Black, Transmissive	
Viewing angle	85/85/85/85	
Aspect Ratio	1 : 2.5	
TFT Interface	3W SPI+RGB24bit	
TFT Driver IC	ST7701P or Equivalent	
CTP Driver IC	ST1633i or equivalent	
CTP Interface	I2C	
CTP FW Version	0x02	
CTP Resolution	376x960	
Backlight Type	LED ,Normally White	
With /Without TP	With CTP	
Surface	Glare	

*Color tone slight changed by temperature and driving voltage.

4. Absolute Maximum Ratings

Item	Symbol	Min	Typ	Max	Unit
Operating Temperature	TOP	-30	—	+85	°C
Storage Temperature	TST	-30	—	+85	°C

Note: Device is subject to be damaged permanently if stresses beyond those absolute maximum ratings listed above

1. Temp. $\leq 60^{\circ}\text{C}$, 90% RH MAX. Temp. $> 60^{\circ}\text{C}$, Absolute humidity shall be less than 90% RH at 60°C



5. Electrical Characteristics

5.1. Operating conditions

Item	Symbol	Min	Typ	Max	Unit
Interface Supply Voltage	VCC	2.5	2.8	3.3	V
Current for Drive	IVCC	—	25	40	mA
Input voltage 'H' level	VIH	0.7*VCC	—	VCC	V
Input voltage 'L' level	VIL	GND	—	0.3*VCC	V
Output voltage 'H' level	VOH	0.8* VCC	—	VCC	V
Output voltage 'L' level	VOL	GND	—	0.2* VCC	V
Supply CTP	TP_VDDT	3.0	3.3	3.6	V
	TP_IDDT	—	2.6	4.0	mA

Note: to avoid power supply noise, please avoid using driving conditions close to min, or max value

5.2. LED driving conditions

Parameter	Symbol	Min.	Typ.	Max.	Unit	Remark
LED current	—	—	30	—	mA	—
LED voltage	VLED+	15.5	17.0	18.5	V	Note 1
LED Life Time	—	50,000	—	—	Hr	Note 2,3,4

Note 1 : There are 1 Groups LED

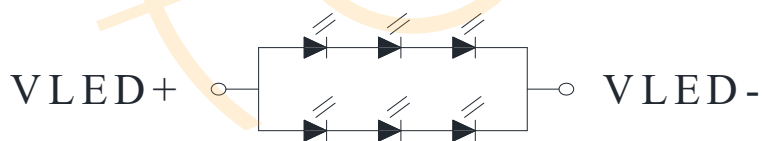

Backlight LED Circuit

Note 2 : $T_a = 25\text{ }^\circ\text{C}$

Note 3 : Brightness to be decreased to 50% of the initial value

Note 4 : The single LED lamp case

6.AC Characteristics

6.1. Serial Interface Characteristics (3-line serial):

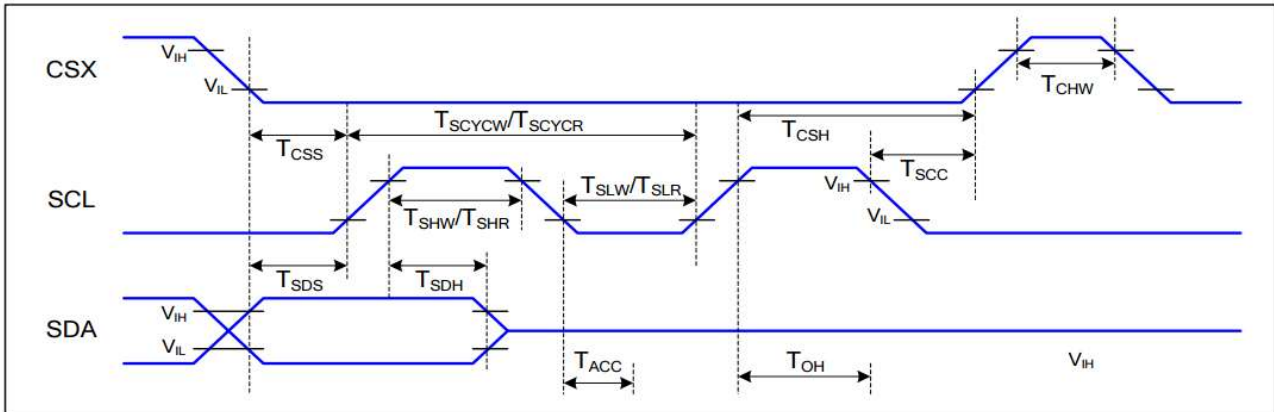

Figure 1 3-line serial Interface Timing Characteristics

Signal	Symbol	Parameter	Min	Max	Unit	Description
CSX	T_{CSS}	Chip select setup time (write)	15		ns	
	T_{CCH}	Chip select hold time (write)	15		ns	
	T_{CSS}	Chip select setup time (read)	60		ns	
	T_{SCC}	Chip select hold time (read)	60		ns	
	T_{CHW}	Chip select "H" pulse width	40		ns	
SCL	T_{SCYCW}	Serial clock cycle (Write)	66		ns	
	T_{SHW}	SCL "H" pulse width (Write)	15		ns	
	T_{SLW}	SCL "L" pulse width (Write)	15		ns	
	T_{SCYCR}	Serial clock cycle (Read)	150		ns	
	T_{SHR}	SCL "H" pulse width (Read)	60		ns	
	T_{SLR}	SCL "L" pulse width (Read)	60		ns	
SDA (DIN)	T_{SDS}	Data setup time	10		ns	
	T_{SDH}	Data hold time	10		ns	

6.2. RGB Interface Characteristics :

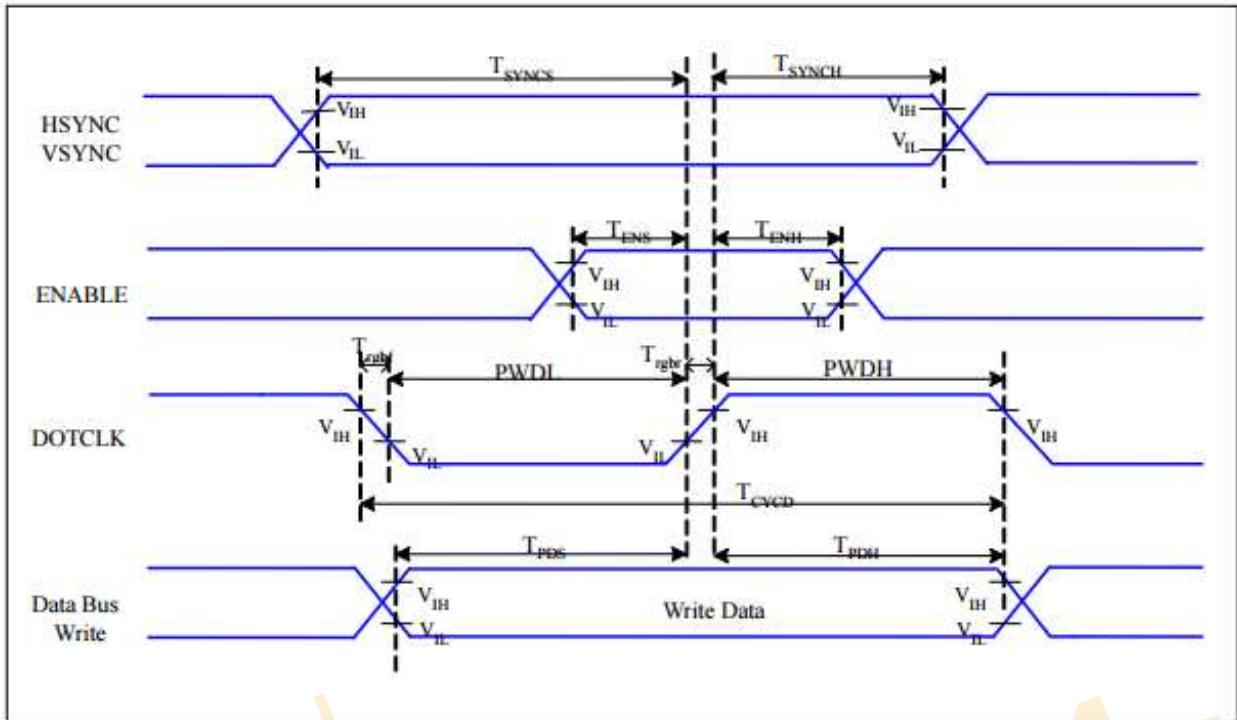

Figure 2 RGB Interface Timing Characteristics

VCC=2.8V, DGND=0V, Ta=25 °C

Signal	Symbol	Parameter	MIN	MAX	Unit	Description
HSYNC, VSYNC	T_{SYNCS}	VSYNC. HSYNC Setup Time	5	-	ns	
ENABLE	T_{ENS}	Enable Setup Time	5	-	ns	
	T_{ENH}	Enable Hold Time	5	-	ns	
DOTCLK	PWDH	DOTCLK High-level Pulse Width	15	-	ns	
	PWDL	DOTCLK Low-level Pulse Width	15	-	ns	
	T_{CYCD}	DOTCLK Cycle Time	33	-	ns	
	Trghr. Trghf	DOTCLK Rise/Fall time	-	15	ns	
DB	T_{PDS}	PD Data Setup Time	5	-	ns	
	T_{PDH}	PD Data Hold Time	5	-	ns	

Table 1 18/16 Bits RGB Interface Timing Characteristics

7.Reset Timing

7.1. Reset Timing

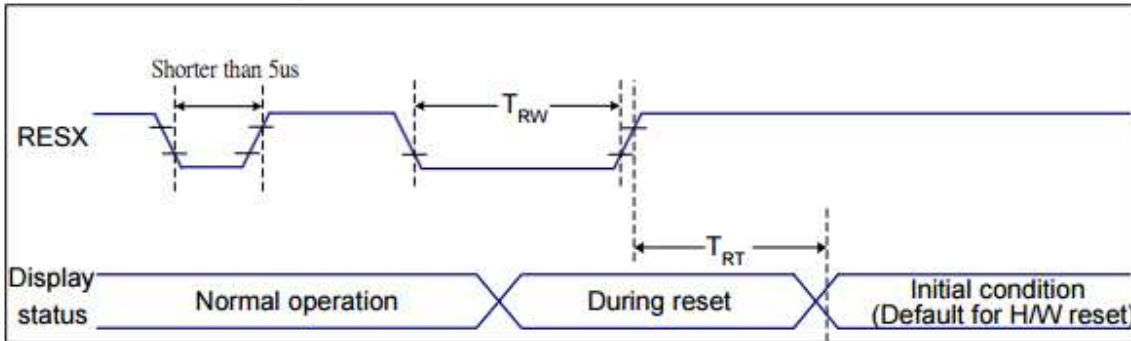

Table 2 Reset Timing

Signal	Symbol	Parameter	Min	Max	Unit
RESX	t_{RW}	Reset pulse duration	10		μ S
	t_{RT}	Reset cancel		5 (note 1,5)	mS
				120 (note 1,6,7)	mS

Notes:

1. The reset cancel also includes required time for loading ID bytes, VCOM setting and other settings from EEPROM (or similar device) to registers.

This loading is done every time when there is HW reset cancel time (t_{RT}) within 10 ms after a rising edge of RESX.

2. Spike due to an electrostatic discharge on RESX line does not cause irregular system reset according to the table below:

RESX Pulse	Action
Shorter than 5 μ s	Reset Rejected
Longer than 9 μ s	Reset
Between 5 μ s and 9 μ s	Reset starts

3. During the Resetting period, the display will be blanked (The display is entering blanking sequence, which maximum time is 120 ms, when Reset Starts at Sleep-Out status. The display remains the blank state in Sleep-In mode). Then return to Default condition for Hardware Reset

4. Spike Rejection also applies during a valid reset pulse as shown below :

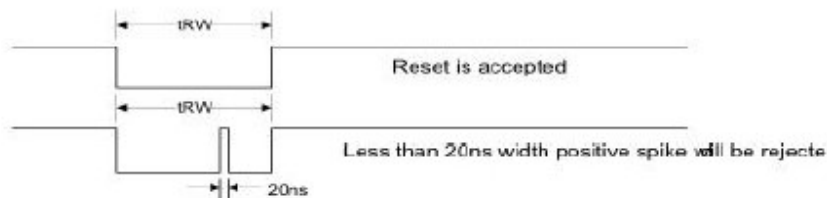

5. When Reset applied during Sleep-In Mode.

6. When Reset applied during Sleep-Out Mode

7. It is necessary to wait 10ms after releasing RESX before sending commands. Also Sleep Out command cannot be sent for 120 ms.

8. Function Description

8.1. Serial Interface (only command)

The serial interface is either 3-lines/9-bits for communication between the micro controller and the LCD driver. The 3-lines serial interface use: CSX (chip enable), SCL (serial clock) and SDA (serial data input/output) is used for interface with MCU only, so it can be stopped when no communication is necessary

Pin description

3-line serial interface (9 bits)

Pin Name	Description
CSX	Chip selection signal
SCL	Serial input CLK
SDA	Serial input data

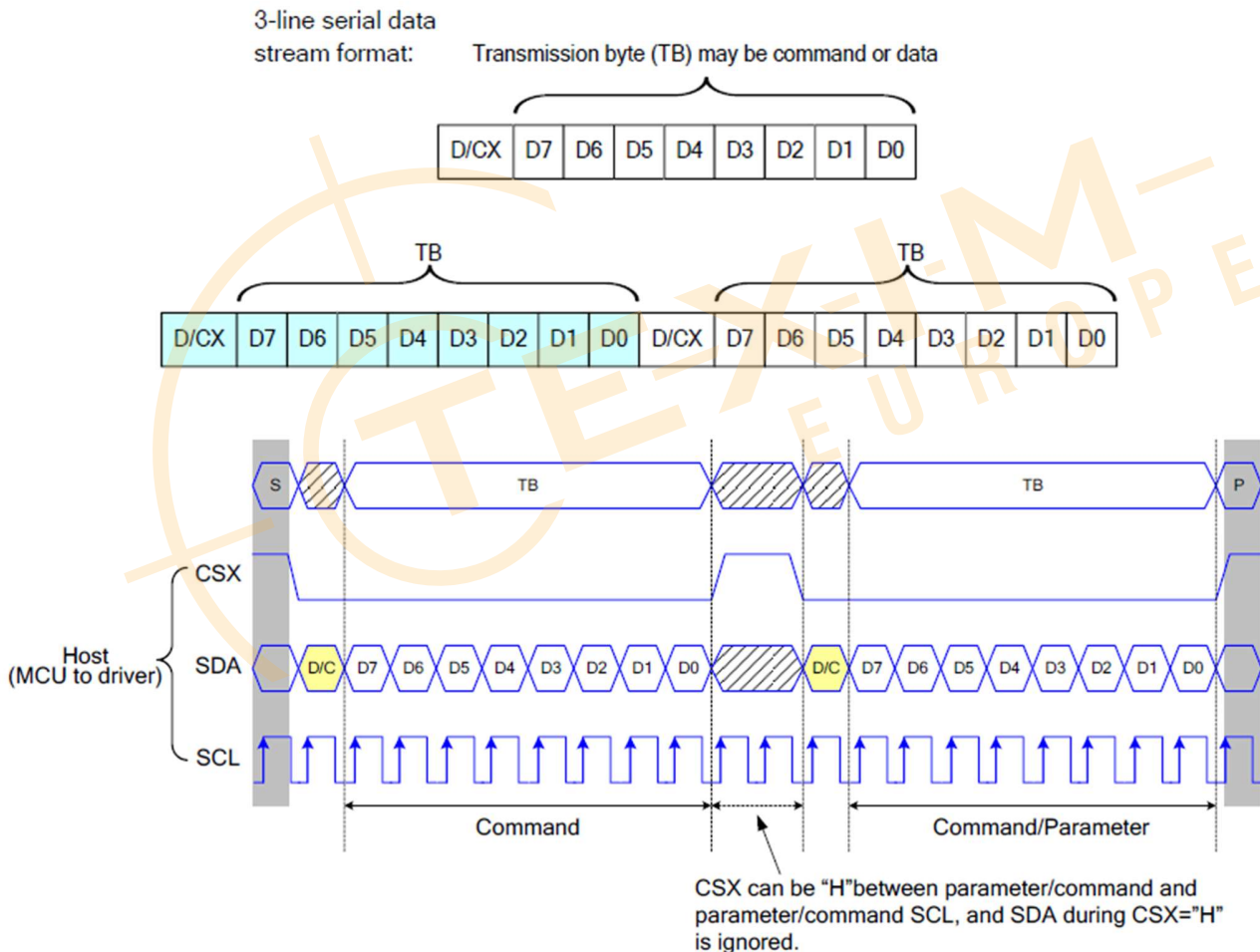

Figure 3 3-line serial interface write protocol (write to register with control bit in transmission)

8.2. RGB Interface

The ST7701P support RGB interface Mode 1 and Mode 2..

The Mode 1 and Mode 2 function is select by setting in the Command 2, please reference application note.

In RGB Mode 1, writing data to line buffer is done by PCLK and Video Data Bus (D[23:0]), when DE is high state.

The external clocks (PCLK, VS and HS) are used for internal displaying clock. So, controller must always transfer PCLK, VS and HS signal to ST7701P.

In RGB Mode 2, back porch of Vsync is defined by VBP_HVRGB [7:0] of RGBCTR command. And back porch of Hsync is defined by HBP_HVRGB [7:0] of RGBCTR command. Front porch of Vsync are not setting by this mode.

RGB I/F Mode	PCLK	DE	VS	HS	DB[23:0]	Register for Blanking Porch setting
RGB Mode 1	Used	Used	Used	Used	Used	Not Used
RGB Mode 2	Used	Not Used	Used	Used	Used	Used

Symbol	Name	Description
PCLK	Pixel clock	Pixel clock for capturing pixels at display interface
HS	Horizontal sync	Horizontal synchronization timing signal
VS	Vertical sync	Vertical synchronization timing signal
DE	Data enable	Data enable signal (assertion indicates valid pixels)
DB[23:0]	Pixel data	Pixel data in 16-bit, 18-bit and 24-bit format

Table 3 The interface signals of RGB interface

1.RGB Color Format

ST7701P supports two kinds of RGB interface, DE mode (mode 1) and HV mode (mode 2), and 16bit/18bit and 24bit data format. When DE mode is selected and the VSYNC, HSYNC, DOTCLK, DE, D[23:0] pins can be used; when HV mode is selected and the VSYNC, HSYNC, DOTCLK, D[23:0] pins can be used. When using RGB interface, only serial interface can be selected.

Pad name	24 bits configuration VIPF[3:0]=0111	18 bits configuration VIPF[3:0]=0110		16 bits configuration VIPF[3:0]=0101
		MDT=0	MDT=1	
DB[23]	R7	Not used	Not used	Not used
DB[22]	R6	Not used	Not used	Not used
DB[21]	R5	R5	Not used	Not used
DB[20]	R4	R4	Not used	R4
DB[19]	R3	R3	Not used	R3
DB[18]	R2	R2	Not used	R2
DB[17]	R1	R1	R5	R1
DB[16]	R0	R0	R4	R0
DB[15]	G7	Not used	R3	Not used
DB[14]	G6	Not used	R2	Not used
DB[13]	G5	G5	R1	G5
DB[12]	G4	G4	R0	G4
DB[11]	G3	G3	G5	G3
DB[10]	G2	G2	G4	G2
DB[09]	G1	G1	G3	G1
DB[08]	G0	G0	G2	G0
DB[07]	B7	Not used	G1	Not used
DB[06]	B6	Not used	G0	Not used
DB[05]	B5	B5	B5	Not used
DB[04]	B4	B4	B4	B4
DB[03]	B3	B3	B3	B3
DB[02]	B2	B2	B2	B2
DB[01]	B1	B1	B1	B1
DB[00]	B0	B0	B0	B0

Table 4 The interface color mapping of RGB interface

2.RGB Interface Definition

The display operation via the RGB interface is synchronized with the VSYNC, HSYNC, and DOTCLK signals. The data can be written only within the specified area with low power consumption by using window address function. The back porch and front porch are used to set the RGB interface timing.

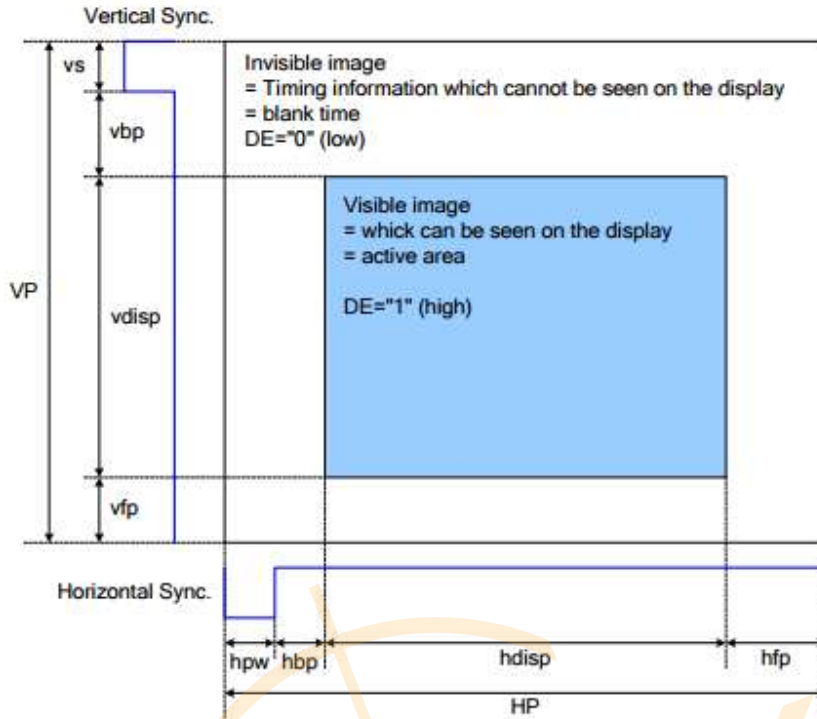

Figure 4 Access Area by RGB Interface

Timing Characteristics

Horizontal input timing

Parameter	Symbol	Values			Unit
		Min.	Typ.	Max.	
DCLK frequency	fclk	-	20	-	MHz
Horizontal Total	HP	-	432	-	DCLK
Hsync Pulse width	hpw	-	10	-	
Horizontal Back Porch	hbp	-	16	-	
Horizontal Valid Data	hdisp	376			
Horizontal Front Porch	hfp	-	30	-	

Vertical input timing

Item	Symbol	Values			Unit
		Min	Typ.	Max.	
Vertical Total	VP	-	1016	-	THT
Vsync Pulse Width	vs	-	10	-	THT
Vertical Back Porch	vbp	-	16	-	THT
Vertical Valid Data	vdisp	960			THT
Vertical Front Porch	vfp	-	30	-	THT

Note:

1. Typical value are related to the setting frame rate is 60Hz.
2. $VS+VBP \leq 254$, $HPW+HBP \leq 255$

3. RGB Interface Mode Selection

ST7701P supports two kinds of RGB interface, DE mode and HV mode. The table shown below uses command C3h to select RGB interface mode.

DE/Sync	RGB Mode
0	DE mode
1	HV mode

4. RGB Interface Timing

The timing chart of RGB interface DE mode is shown as follows.

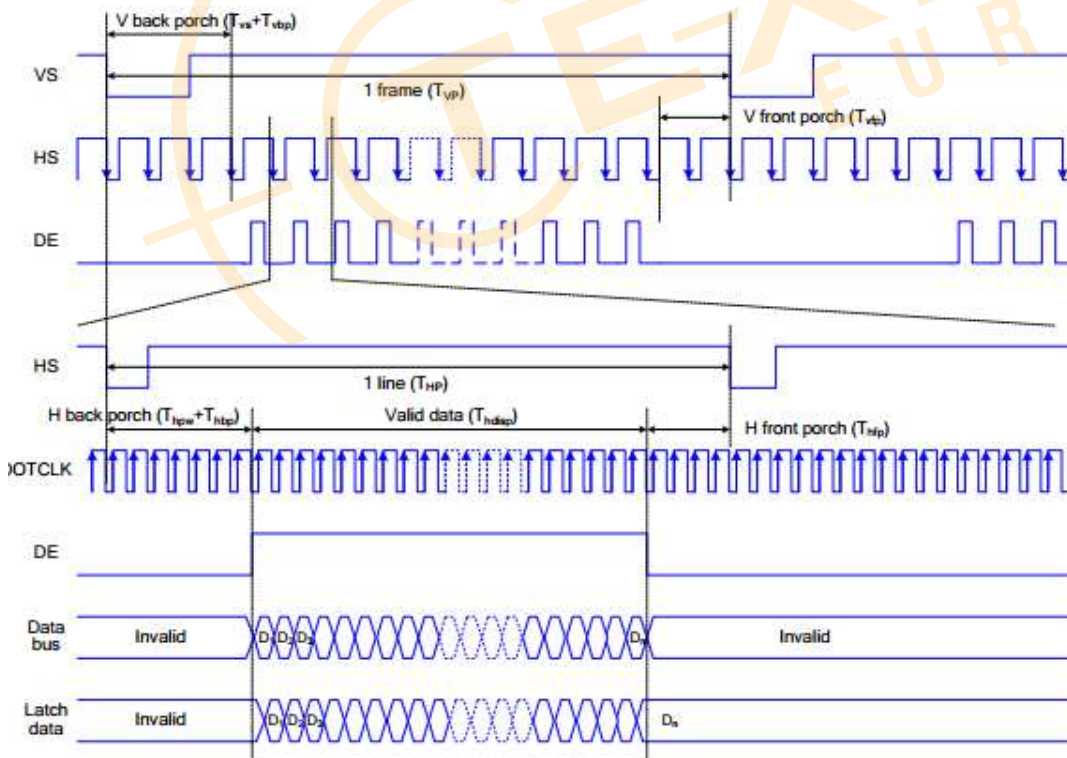

Note: The setting of front porch and back porch in host must match that in IC as this mode.

Figure 5 Timing Chart of Signals in RGB Interface DE Mod

The timing chart of RGB interface HV mode is shown as follows.

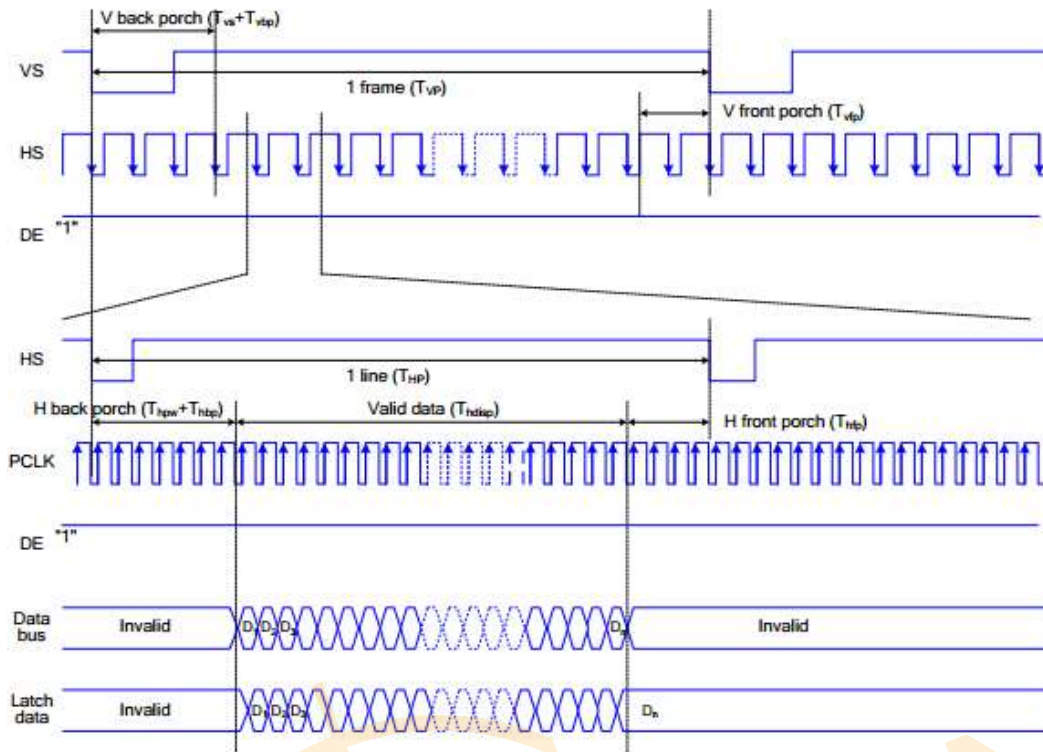
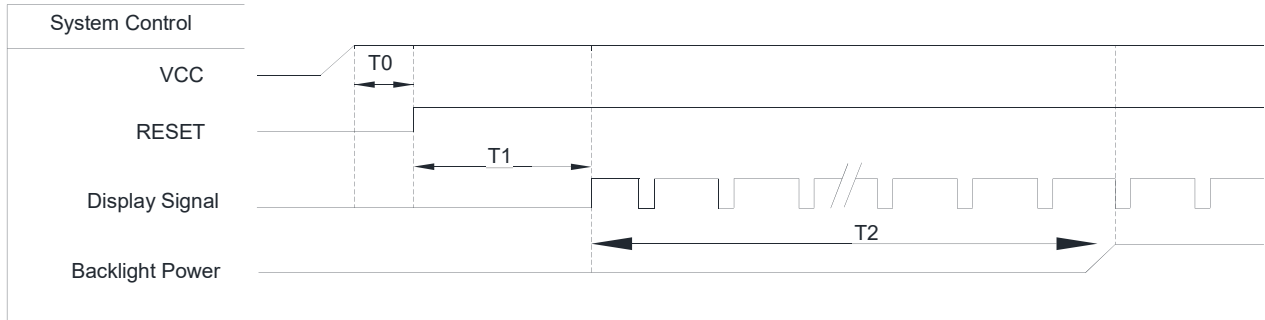

Figure 6 Timing chart of RGB interface HV mode

8.3. Power ON/OFF Sequence

1.Power - On Timing Sequence



Symbol	Description	Min. Time	Unit
T0	System power stability to RESET signal	0	ms
T1	GRB RESET="High to Display Signal output	10	ms
T2	Display signal output to Backlight Power on	250	ms

2.Power - off Timing Sequence

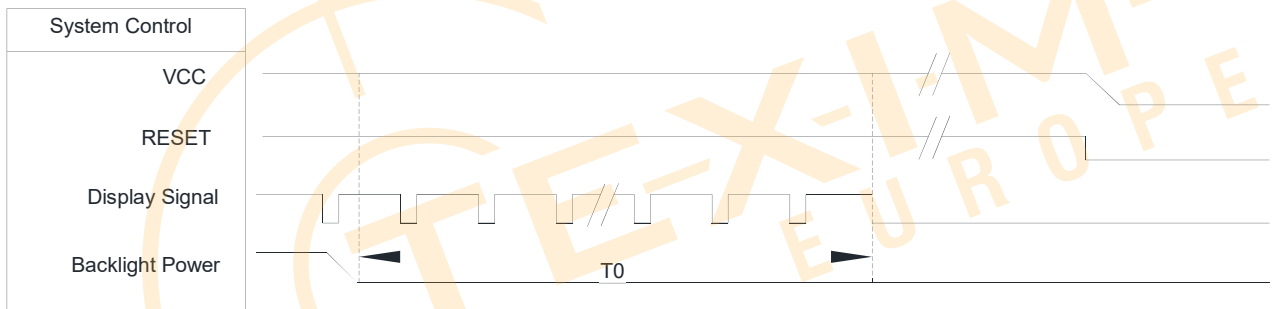

Symbol	Description	Min. Time	Unit
T0	Backlight Power off to IC internal voltage discharge complete	85	ms

9. Optical Characteristics

Item	Symbol	Condition.	Min	Typ.	Max.	Unit	Remark	
Response time	Tr+ Tf	$\theta=0^\circ$ 、 $\Phi=0^\circ$	-	30	35	ms	Note 3	
Contrast ratio	CR	At optimized viewing angle	1000	1200	-	-	Note 4	
Color Chromaticity	White	Wx	$\theta=0^\circ$ 、 $\Phi=0$	0.258	0.308	0.358	Note 2,6,7	
		Wy		0.295	0.345	0.395		
Viewing angle	Hor.	Θ_R	CR \geq 10	75	85	-	Deg.	Note 1
		Θ_L		75	85	-		
	Ver.	Φ_T		75	85	-		
		Φ_B		75	85	-		
Brightness	-	-	700	900	-	cd/m ²	Center of display	
Uniformity	(U)	-	70	-	-	%	Note5	

Ta=25±2°C

Note 1: Definition of viewing angle range

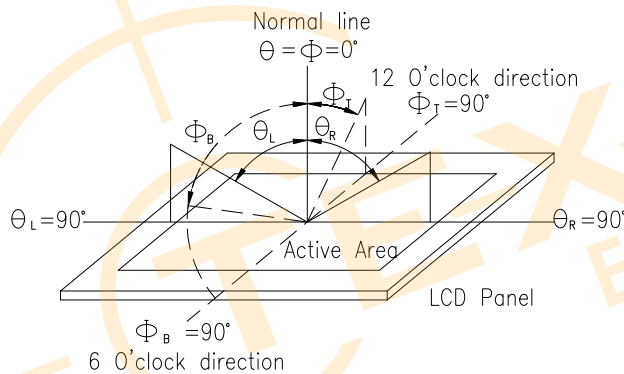

Fig. 9.1. Definition of viewing angle

Note 2: Test equipment setup:

After stabilizing and leaving the panel alone at a driven temperature for 10 minutes, the measurement should be executed. Measurement should be executed in a stable, windless, and dark room. Optical specifications are measured by Topcon BM-7 or BM-5 luminance meter 1.0° field of view at a distance of 50cm and normal direction.

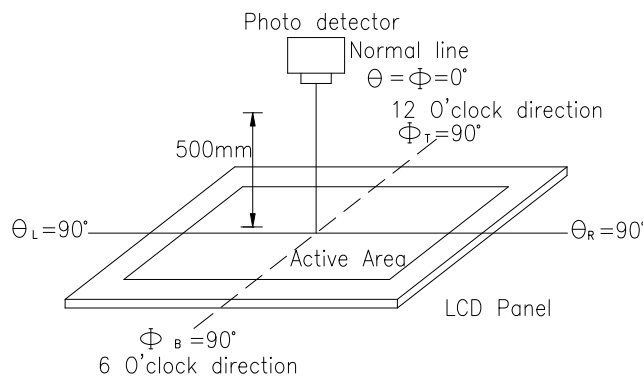
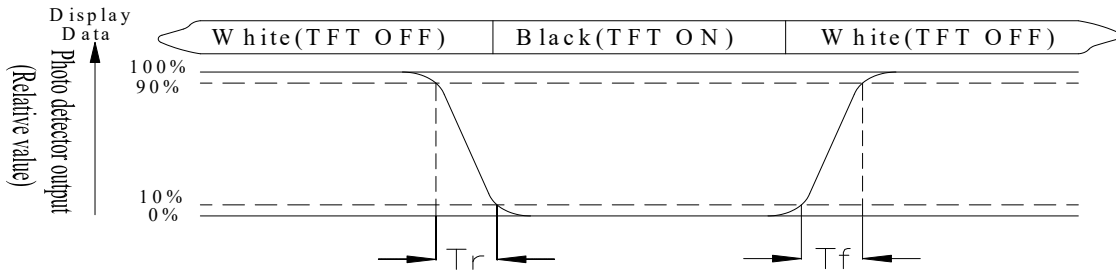

Fig. 9.2. Optical measurement system setup

Note 3: Definition of Response time:

The response time is defined as the LCD optical switching time interval between "White" state and "Black" state. Rise time, T_r , is the time between photo detector output intensity changed from 90% to 10%. And fall time, T_f , is the time between photo detector output intensity changed from 10% to 90%



Note 4: Definition of contrast ratio:

The contrast ratio is defined as the following expression.

$$\text{Contrast ratio (CR)} = \frac{\text{Luminance measured when LCD on the "White" state}}{\text{Luminance measured when LCD on the "Black" state}}$$

Note 5: Definition of Luminance Uniformity

Active area is divided into 5 measuring areas (reference the picture in below). Every measuring point is placed at the center of each measuring area.

Luminance Uniformity (U) = $L_{\min}/L_{\max} \times 100\%$

L = Active area length

W = Active area width

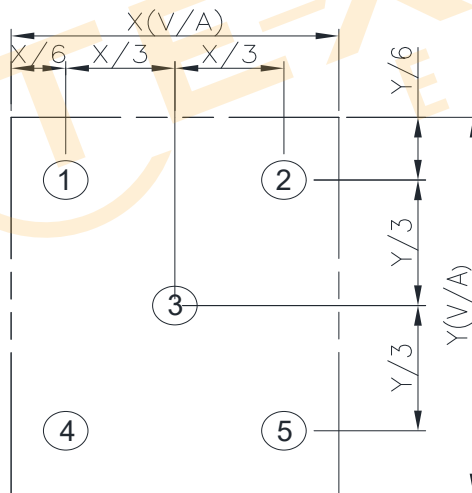

Fig9.3. Definition of uniformity

Note 6: Definition of color chromaticity (CIE 1931)

Color coordinates measured at the center point of LCD

Note 7: Measured at the center area of the panel when all the input terminals of LCD panel are electrically opened.

10.Interface

10.1. LCM PIN Definition

Match connector: Molex 5025984593 or equivalent.

Pin No.	Symbol	Description
1	VLED-	LED backlight cathode
2	VLED+	LED backlight anode
3	GND	Power ground
4	VCC	Power Supply for Digital Circuit
5	SDA	SDA: Serial data input/output bidirectional pin for SPI Interface.
6	SCL	SCL: Serial clock input for SPI interface.
7	CSX	- A chip select signal Low: the chip is selected and accessible High: the chip is not selected and not accessible
8	RESET	Reset signal(low active)
9	GND	Power ground
10~17	R7~R0	Red Data 7~0
18	GND	Power ground
19~26	G7~G0	Green Data 7~0
27	GND	Power ground
28~35	B7~B0	Blue Data 7~0
36	DE	Data Enable (ENABLE)
37	PCLK	Clock Signals ; Latch Data at the Falling Edge (DOTCLK)
38	HS	Line synchronizing signal for RGB interface operation (HSYNC)
39	VS	Frame synchronizing signal for RGB interface operation (VSYNC)
40	TP_RST	CTP External Reset, Low is active
41	TP_INT	CTP External interrupt to the host
42	TP_SDA	CTP I2C data input and output
43	TP_SCL	CTP I2C clock input
44	TP_VDDT	CTP Power supply: +3.3V
45	TP_VSS	CTP Ground for analog circuit

11. Block Diagram

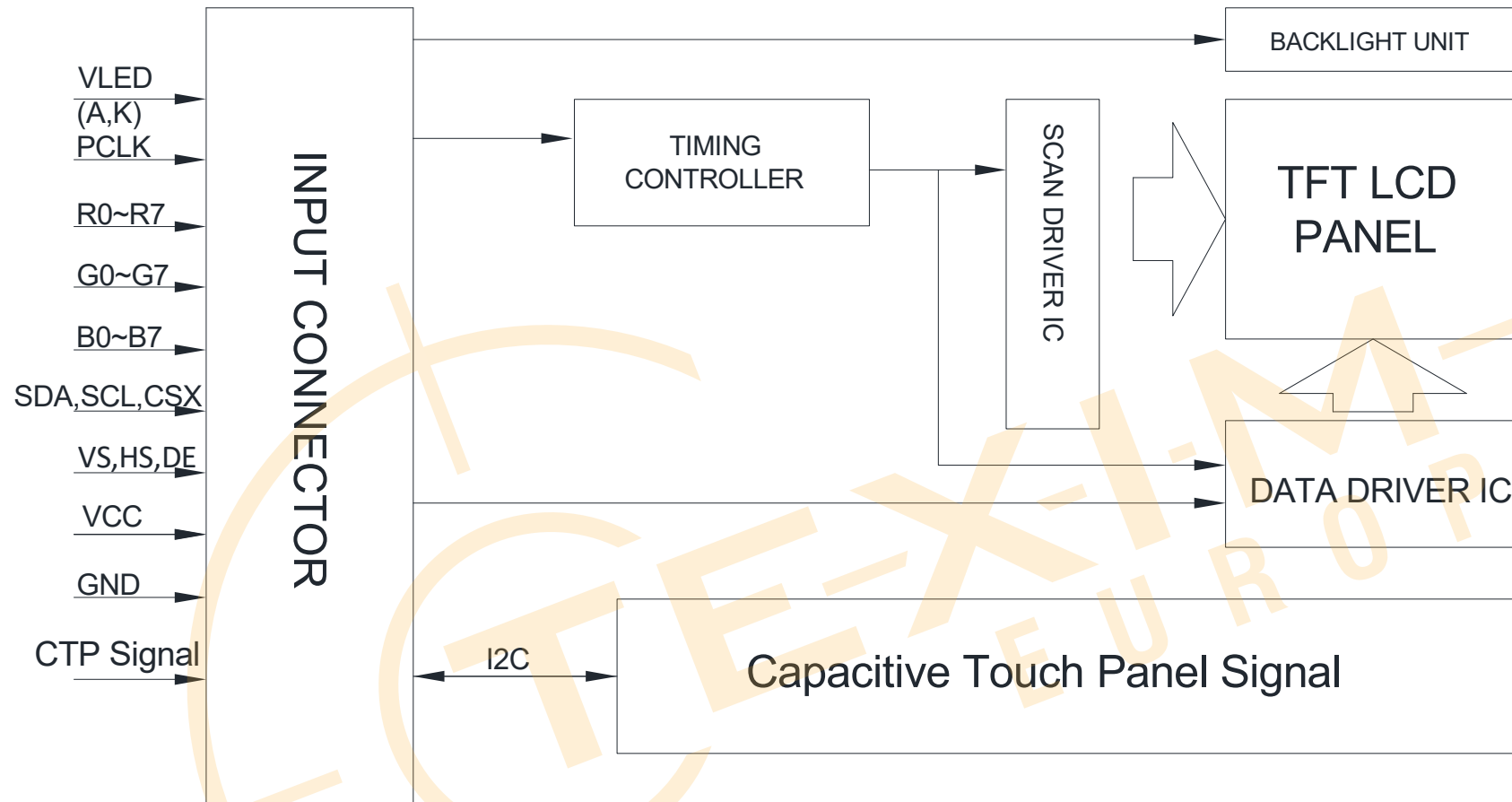

12. Reliability

Content of Reliability Test (Wide temperature, -30°C~85°C)

Environmental Test			
Test Item	Content of Test	Test Condition	Note
High Temperature storage	Endurance test applying the high storage temperature for a long time.	85°C 240hrs	2
Low Temperature storage	Endurance test applying the low storage temperature for a long time.	-30°C 240hrs	1,2
High Temperature Operation	Endurance test applying the electric stress (Voltage & Current) and the thermal stress to the element for a long time.	85°C 240hrs	2
Low Temperature Operation	Endurance test applying the electric stress under low temperature for a long time.	-30°C 240hrs	1,2
High Temperature/ Humidity storage	The module should be allowed to stand at 60°C,90%RH max	60°C,90%RH 240hrs	1,2
Thermal shock resistance	<p>The sample should be allowed stand the following 10 cycles of storage</p> <p style="text-align: center;">-30°C 25°C 85°C</p> <p style="text-align: center;">30min 5min 30min</p> <p style="text-align: center;">1 cycle</p>	-30°C/85°C 10 cycles	2
Vibration test	Endurance test applying the vibration during transportation and using.	Total fixed amplitude : 1.5mm Vibration Frequency : 10~55Hz One cycle 60 seconds to 3 directions of X,Y,Z for Each 15 minutes	3
Static electricity test	Endurance test applying the electric stress to the terminal.	VS=±TBD(contact), ±TBD(air), RS=330Ω CS=150pF 5 times	4

Note1: No dew condensation to be observed.

Note2: The function test shall be conducted after 4 hours storage at the normal Temperature and humidity after remove from the test chamber.

Note3: The packing have to including into the vibration testing.

Note4: Endurance test applying the electric stress to the finished product housing

13. Contour Drawing

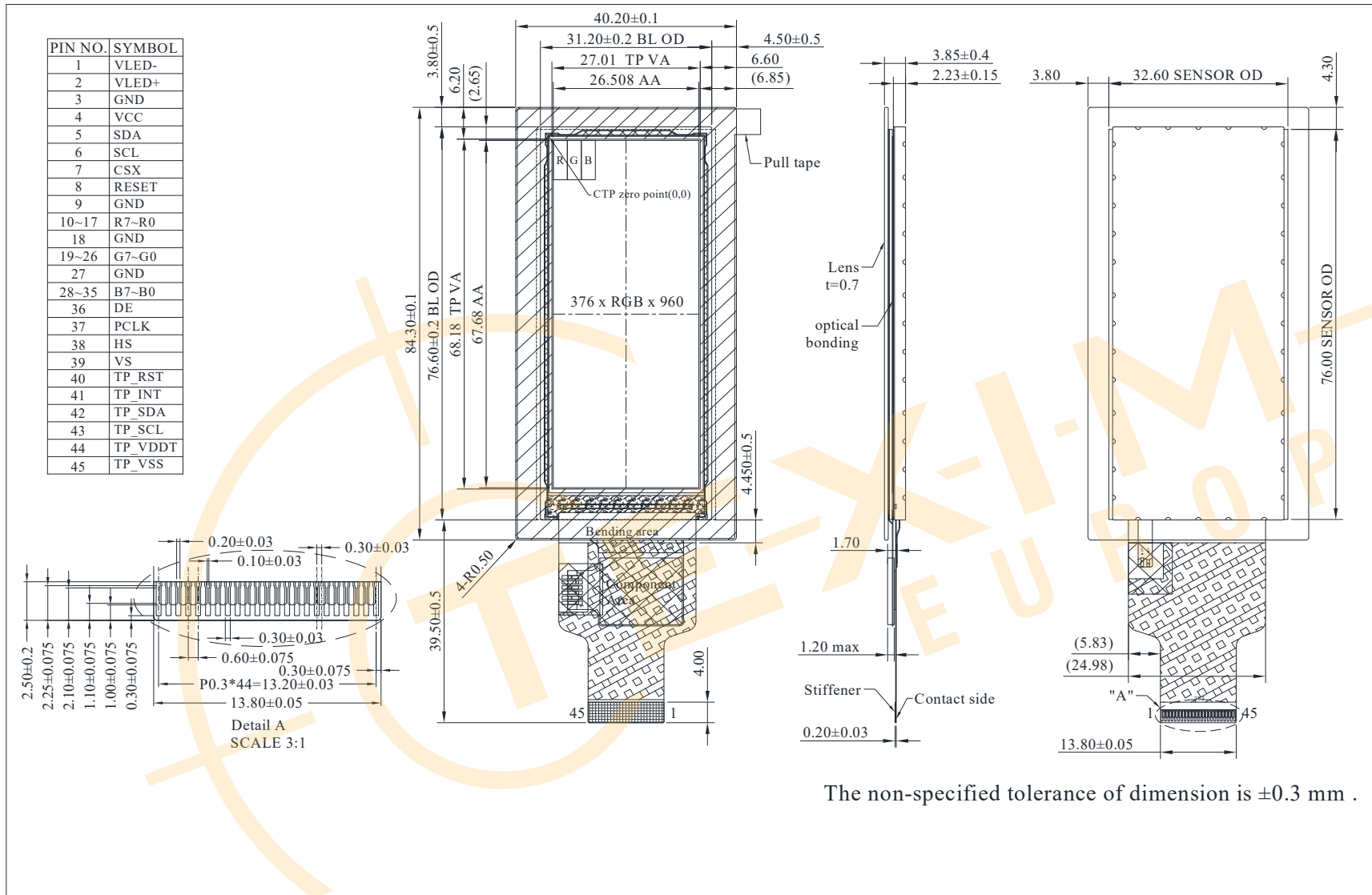

14.Initial Code for Reference

```
void ST7701P_SPI+RGB_0286A2(void)
{
    GATE = 960;
    SOURCE = 376;

    IC_RST = 1;
    asm("nop");
    asm("nop");
    asm("nop");
    delay(100);
    IC_RST = 0;
    delay(200);
    asm("nop");
    asm("nop");
    asm("nop");
    IC_RST = 1;
    asm("nop");
    asm("nop");
    asm("nop");
    delay(100);

    //-----ST7701P initial-----

    Write_Command(0x11);
    Write_Data(0x00);

    Write_Command(0xFF);
    Write_Data(0x77);
    Write_Data(0x01);
    Write_Data(0x00);
    Write_Data(0x00);
    Write_Data(0x13);

    Write_Command(0xEF);
    Write_Data(0x08);

    Write_Command(0xFF);
    Write_Data(0x77);
    Write_Data(0x01);
    Write_Data(0x00);
    Write_Data(0x00);
    Write_Data(0x10);

    Write_Command(0xC0);
    Write_Data(0x77);
    Write_Data(0x00);
}
```

```
Write_Command(0xC1);  
Write_Data(0x0C);  
Write_Data(0x0C);
```

```
Write_Command(0xC2);  
Write_Data(0x07);  
Write_Data(0x02);
```

```
Write_Command(0xCC);  
Write_Data(0x10);
```

```
Write_Command(0xB0);  
Write_Data(0x00);  
Write_Data(0x0C);  
Write_Data(0x19);  
Write_Data(0x0B);  
Write_Data(0x0F);  
Write_Data(0x06);  
Write_Data(0x05);  
Write_Data(0x08);  
Write_Data(0x08);  
Write_Data(0x1F);  
Write_Data(0x04);  
Write_Data(0x11);  
Write_Data(0x0F);  
Write_Data(0x26);  
Write_Data(0x2F);  
Write_Data(0x1D);
```

```
Write_Command(0xB1);  
Write_Data(0x00);  
Write_Data(0x17);  
Write_Data(0x19);  
Write_Data(0x0F);  
Write_Data(0x12);  
Write_Data(0x05);  
Write_Data(0x05);  
Write_Data(0x08);  
Write_Data(0x07);  
Write_Data(0x1F);  
Write_Data(0x03);  
Write_Data(0x10);  
Write_Data(0x10);  
Write_Data(0x27);  
Write_Data(0x2F);  
Write_Data(0x1D);
```

```
Write_Command(0xFF);  
Write_Data(0x77);  
Write_Data(0x01);
```

```
Write_Data(0x00);  
Write_Data(0x00);  
Write_Data(0x11);
```

```
Write_Command(0xB0);  
Write_Data(0x25);
```

```
Write_Command(0xB1);  
Write_Data(0x76);
```

```
Write_Command(0xB2);  
Write_Data(0x81);
```

```
Write_Command(0xB3);  
Write_Data(0x80);
```

```
Write_Command(0xB5);  
Write_Data(0x4E);
```

```
Write_Command(0xB7);  
Write_Data(0x85);
```

```
Write_Command(0xB8);  
Write_Data(0x20);
```

```
Write_Command(0xC1);  
Write_Data(0x78);
```

```
Write_Command(0xC2);  
Write_Data(0x78);
```

```
Write_Command(0xD0);  
Write_Data(0x88);
```

```
Write_Command(0xE0);  
Write_Data(0x00);  
Write_Data(0x00);  
Write_Data(0x02);  
Write_Data(0x00);  
Write_Data(0x00);  
Write_Data(0x0C);
```

```
Write_Command(0xE1);  
Write_Data(0x02);  
Write_Data(0x8C);  
Write_Data(0x04);  
Write_Data(0x8C);  
Write_Data(0x01);  
Write_Data(0x8C);  
Write_Data(0x03);  
Write_Data(0x8C);
```

```
Write_Data(0x00);  
Write_Data(0x44);  
Write_Data(0x44);
```

```
Write_Command(0xE2);  
Write_Data(0x03);  
Write_Data(0x03);  
Write_Data(0x03);  
Write_Data(0x03);  
Write_Data(0x00);  
Write_Data(0x00);  
Write_Data(0xD4);  
Write_Data(0x00);  
Write_Data(0x00);  
Write_Data(0x00);  
Write_Data(0x00);  
Write_Data(0xD4);  
Write_Data(0x00);
```

```
Write_Command(0xE3);  
Write_Data(0x00);  
Write_Data(0x00);  
Write_Data(0x33);  
Write_Data(0x33);
```

```
Write_Command(0xE4);  
Write_Data(0x44);  
Write_Data(0x44);
```

```
Write_Command(0xE5);  
Write_Data(0x09);  
Write_Data(0xD2);  
Write_Data(0x35);  
Write_Data(0x8C);  
Write_Data(0x0B);  
Write_Data(0xD4);  
Write_Data(0x35);  
Write_Data(0x8C);  
Write_Data(0x05);  
Write_Data(0xCE);  
Write_Data(0x35);  
Write_Data(0x8C);  
Write_Data(0x07);  
Write_Data(0xD0);  
Write_Data(0x35);  
Write_Data(0x8C);
```

```
Write_Command(0xE6);  
Write_Data(0x00);  
Write_Data(0x00);  
Write_Data(0x33);  
Write_Data(0x33);
```

```
Write_Command(0xE7);  
Write_Data(0x44);  
Write_Data(0x44);
```

```
Write_Command(0xE8);  
Write_Data(0x08);  
Write_Data(0xD1);  
Write_Data(0x35);  
Write_Data(0x8C);  
Write_Data(0x0A);  
Write_Data(0xD3);  
Write_Data(0x35);  
Write_Data(0x8C);  
Write_Data(0x04);  
Write_Data(0xCD);  
Write_Data(0x35);  
Write_Data(0x8C);  
Write_Data(0x06);  
Write_Data(0xCF);  
Write_Data(0x35);  
Write_Data(0x8C);
```

```
Write_Command(0xEB);  
Write_Data(0x00);  
Write_Data(0x01);  
Write_Data(0xE4);  
Write_Data(0xE4);  
Write_Data(0x44);  
Write_Data(0x33);
```

```
Write_Command(0xED);  
Write_Data(0x77);  
Write_Data(0x66);  
Write_Data(0x55);  
Write_Data(0x44);  
Write_Data(0xCA);  
Write_Data(0xF1);  
Write_Data(0x03);  
Write_Data(0xBF);  
Write_Data(0xFB);  
Write_Data(0x30);  
Write_Data(0x1F);  
Write_Data(0xAC);  
Write_Data(0x44);  
Write_Data(0x55);  
Write_Data(0x66);  
Write_Data(0x77);
```

```
Write_Command(0xEF);  
Write_Data(0x10);
```

```
Write_Data(0x0D);  
Write_Data(0x04);  
Write_Data(0x08);  
Write_Data(0x3F);  
Write_Data(0x1F);
```

```
Write_Command(0xFF);  
Write_Data(0x77);  
Write_Data(0x01);  
Write_Data(0x00);  
Write_Data(0x00);  
Write_Data(0x13);
```

```
Write_Command(0xE8);  
Write_Data(0x00);  
Write_Data(0x0E);
```

```
Write_Command(0x11);  
Write_Data(0x00);  
delay(120);
```

```
Write_Command(0xE8);  
Write_Data(0x00);  
Write_Data(0x0C);  
delay(20);
```

```
Write_Command(0xE8);  
Write_Data(0x00);  
Write_Data(0x00);
```

```
Write_Command(0xFF);  
Write_Data(0x77);  
Write_Data(0x01);  
Write_Data(0x00);  
Write_Data(0x00);  
Write_Data(0x00);
```

```
Write_Command(0x29);  
Write_Data(0x00);
```

```
Write_Command(0x35);  
Write_Data(0x00);
```

```
Write_Command(0x36);  
Write_Data(0x00);
```

```
}
```



winstar

LCM Sample Estimate Feedback Sheet

Module Number : _____

Page: 1

1、Panel Specification :

- 1. Panel Type : Pass NG , _____
- 2. View Direction : Pass NG , _____
- 3. Numbers of Dots : Pass NG , _____
- 4. View Area : Pass NG , _____
- 5. Active Area : Pass NG , _____
- 6. Operating Temperature : Pass NG , _____
- 7. Storage Temperature : Pass NG , _____
- 8. Others : _____

2、Mechanical

- 1. PCB Size : Pass NG , _____
- 2. Frame Size : Pass NG , _____
- 3. Material of Frame : Pass NG , _____
- 4. Connector Position : Pass NG , _____
- 5. Fix Hole Position : Pass NG , _____
- 6. Backlight Position : Pass NG , _____
- 7. Thickness of PCB : Pass NG , _____
- 8. Height of Frame to PCB : Pass NG , _____
- 9. Height of Module : Pass NG , _____
- 10. Others : Pass NG , _____

3、Relative Hole Size :

- 1. Pitch of Connector : Pass NG , _____
- 2. Hole size of Connector : Pass NG , _____
- 3. Mounting Hole size : Pass NG , _____
- 4. Mounting Hole Type : Pass NG , _____
- 5. Others : Pass NG , _____

4、Backlight Specification :

- 1. B/L Type : Pass NG , _____
- 2. B/L Color : Pass NG , _____
- 3. B/L Driving Voltage (Reference for LED) : Pass NG , _____
- 4. B/L Driving Current : Pass NG , _____
- 5. Brightness of B/L : Pass NG , _____
- 6. B/L Solder Method : Pass NG , _____
- 7. Others : Pass NG , _____

>> **Go to page 2** <<



Winstar Module Number : _____

Page: 2

5、Electronic Characteristics of Module :

- | | | | |
|------------------------------|-------------------------------|-------------------------------|-------|
| 1. Input Voltage : | <input type="checkbox"/> Pass | <input type="checkbox"/> NG , | _____ |
| 2. Supply Current : | <input type="checkbox"/> Pass | <input type="checkbox"/> NG , | _____ |
| 3. Driving Voltage for LCD : | <input type="checkbox"/> Pass | <input type="checkbox"/> NG , | _____ |
| 4. Contrast for LCD : | <input type="checkbox"/> Pass | <input type="checkbox"/> NG , | _____ |
| 5. B/L Driving Method : | <input type="checkbox"/> Pass | <input type="checkbox"/> NG , | _____ |
| 6. Negative Voltage Output : | <input type="checkbox"/> Pass | <input type="checkbox"/> NG , | _____ |
| 7. Interface Function : | <input type="checkbox"/> Pass | <input type="checkbox"/> NG , | _____ |
| 8. LCD Uniformity : | <input type="checkbox"/> Pass | <input type="checkbox"/> NG , | _____ |
| 9. ESD test : | <input type="checkbox"/> Pass | <input type="checkbox"/> NG , | _____ |
| 10. Others : | <input type="checkbox"/> Pass | <input type="checkbox"/> NG , | _____ |

6、Summary :

Sales signature : _____

Customer Signature : _____

Date : / / _____

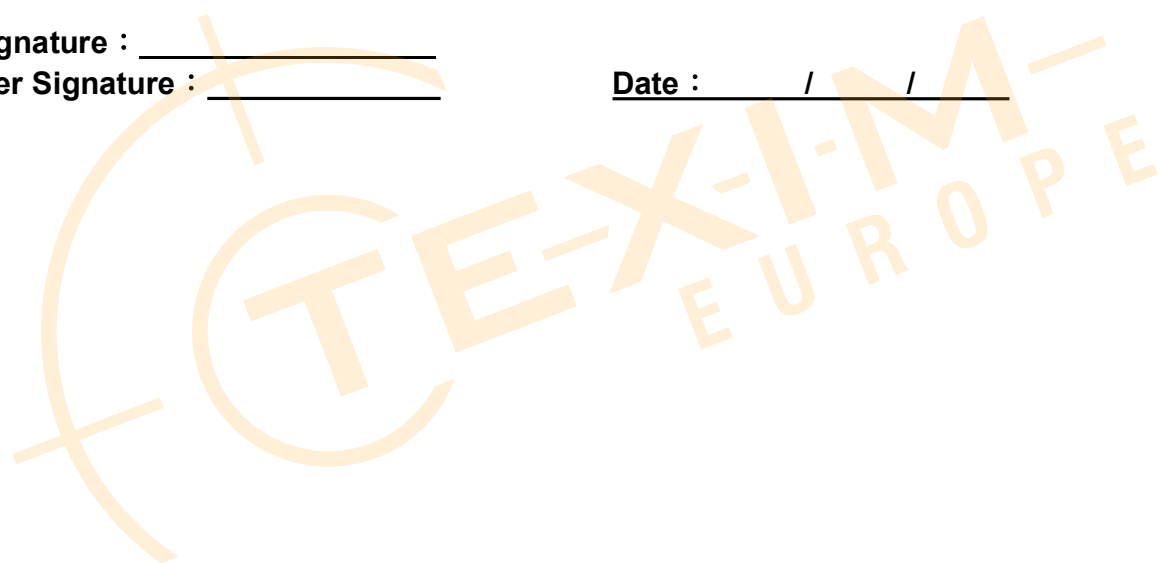

Disclaimer

ALL PRODUCTS, PRODUCT SPECIFICATIONS AND DATA ARE SUBJECT TO CHANGE WITHOUT NOTICE TO IMPROVE RELIABILITY, FUNCTION OR DESIGN OR OTHERWISE.

Texim Europe B.V. its affiliates, agents, and employees, and all persons acting on its or their behalf (collectively, "Texim"), disclaim any and all liability for any errors, inaccuracies or incompleteness contained in any datasheet or in any other disclosure relating to any product.

Texim makes no warranty, representation or guarantee regarding the suitability of the products for any particular purpose or the continuing production of any product.

It is the customer's responsibility to validate that a particular product with the properties described in the product specification is suitable for use in a particular application.

Parameters provided in datasheets and / or specifications may vary in different applications and performance may vary over time.

All operating parameters, including typical parameters, must be validated for each customer application by the customer's technical experts.

Please contact us if you have any questions about the contents of the datasheet.

This may not be the latest version of the datasheet. Please check with us if a later version is available.

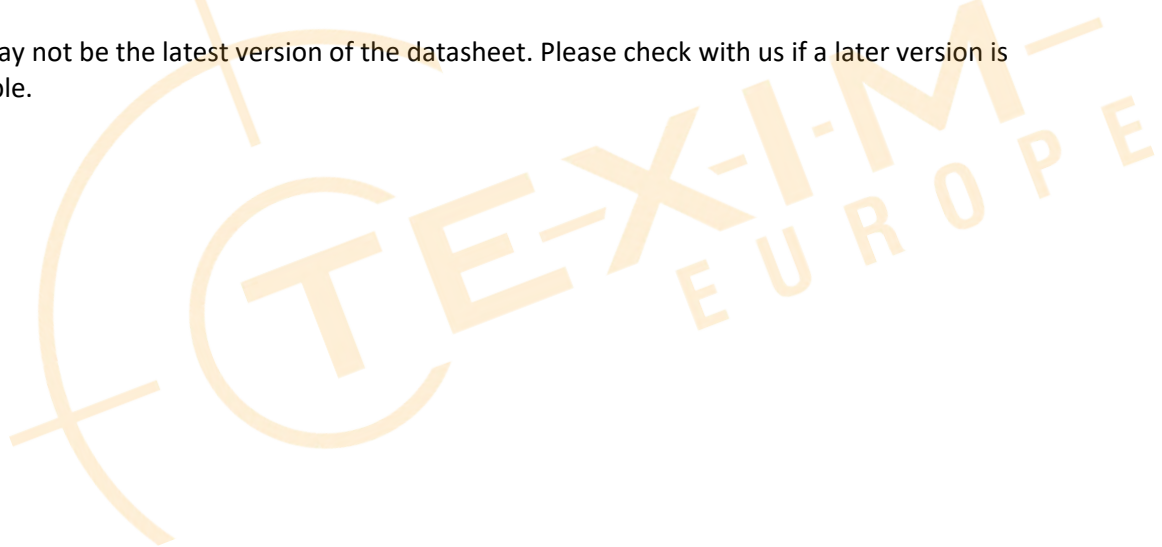



Headquarters & Warehouse

Elektrostraat 17
 NL-7483 PG Haaksbergen
 The Netherlands

T: +31 (0)53 573 33 33
 E: info@texim-europe.com
 Homepage: www.texim-europe.com



The Netherlands

Elektrostraat 17
 NL-7483 PG Haaksbergen

T: +31 (0)53 573 33 33
 E: nl@texim-europe.com



Belgium

Zuiderlaan 14, box 10
 B-1731 Zellik

T: +32 (0)2 462 01 00
 E: belgium@texim-europe.com



UK & Ireland

St Mary's House, Church Lane
 Carlton Le Moorland
 Lincoln LN5 9HS

T: +44 (0)1522 789 555
 E: uk@texim-europe.com



Germany

Bahnhofstrasse 92
 D-25451 Quickborn

T: +49 (0)4106 627 07-0
 E: germany@texim-europe.com



Germany

Martin-Kollar-Strasse 9
 D-81829 München

T: +49 (0)89 436 086-0
 E: muenchen@texim-europe.com



Austria

Martin-Kollar-Strasse 9
 D-81829 München

T: +49 (0)89 436 086-0
 E: austria@texim-europe.com



Nordic

Stockholmsgade 45
 2100 Copenhagen

T: +45 88 20 26 30
 E: nordic@texim-europe.com



Italy

Martin-Kollar-Strasse 9
 D-81829 München

T: +49 (0)89 436 086-0
 E: italy@texim-europe.com