

# TFT DISPLAY SPECIFICATION

Distributed by:



**WINSTAR Display Co.,Ltd.**  
**華凌光電股份有限公司**



# Winstar Display Co., LTD

## 華凌光電股份有限公司



WEB: <https://www.winstar.com.tw> E-mail: [sales@winstar.com.tw](mailto:sales@winstar.com.tw)

### SPECIFICATION

**CUSTOMER :** \_\_\_\_\_

**MODULE NO.:** WF1560ATYFA5LHB0#

<b>APPROVED BY:</b>  ( FOR CUSTOMER USE ONLY )	<b>PCB VERSION:</b>	<b>DATA:</b>
	<input type="checkbox"/> Precaution in use of TFT module: <a href="https://www.winstar.com.tw/technology/download/declaration.html">https://www.winstar.com.tw/technology/download/declaration.html</a>	

SALES BY	APPROVED BY	CHECKED BY	PREPARED BY
			葉虹蘭
<b>ISSUED DATE: 2026/05/12</b>			



**Winstar Display Co., LTD**  
華凌光電股份有限公司

MODLE NO :

**RECORDS OF REVISION**

**DOC. FIRST ISSUE**

VERSION	DATE	REVISED PAGE NO.	SUMMARY
0	2025/12/03		First issue
A	2026/05/12		Modify General Specifications



# Contents

1. Module Classification Information
2. General Specifications
3. Absolute Maximum Ratings
4. Electrical Characteristics
5. Optical Characteristics
6. Interface
7. Reliability
8. Contour Drawing
9. Inspection Specification
10. Other



# 1. Module Classification Information

W F 1560 A T Y F A5 L H B 0 #  
 ① ② ③ ④ ⑤ ⑥ ⑦ ⑧ ⑨ ⑩ ⑪ ⑫ ⑬

①	Brand : WINSTAR DISPLAY CORPORATION												
②	Display Type : F→TFT Type, J→Custom TFT												
③	Display Size : 15.6" TFT												
④	Model serials no.												
⑤	Backlight Type :	F→CCFL, White S→LED, High Light White						T→LED, White Z→Nichia LED, White					
⑥	LCD Polarize Type/ Temperature range/ Gray Scale Inversion Direction	A→Transmissive, N.T, IPS TFT C→Transmissive, N. T, 6:00 ; F→Transmissive, N.T,12:00 ; I→Transmissive, W. T, 6:00 K→Transflective, W.T,12:00 L→Transmissive, W.T,12:00 N→Transmissive, Super W.T, 6:00						Q→Transmissive, Super W.T, 12:00 R→Transmissive, Super W.T, O-TFT V→Transmissive, Super W.T, VA TFT W→Transmissive, Super W.T, IPS TFT X→Transmissive, W.T, VA TFT Y→Transmissive, W.T, IPS TFT Z→Transmissive, W.T, O-TFT					
⑦	A : TFT LCD B : TFT+SCREW HOLES+CONTROL BOARD C : TFT+ SCREW HOLES +A/D BOARD D : TFT+ SCREW HOLES +A/D BOARD+CONTROL BOARD E : TFT+ SCREW HOLES +POWER BOARD						F : TFT+CONTROL BOARD G : TFT+ SCREW HOLES H : TFT+D/V BOARD I : TFT+ SCREW HOLES +D/V BOARD J : TFT+POWER BD						
⑧	Resolution:												
	M	1024768	N	128128	P	1280800	Q	480800	R	640320	S	480128	
	T	800320	U	8001280	V	176220	W	1280398	X	1024250	Y	1920720	
	A5	19201080	A6	480480	A7	10801920	A8	135240	A9	480640	B2	122250	
	B3	340800	B4	2801424	B5	12001920	B6	4801280	B7	800800	B8	40160	
⑨	D: Digital		L:LVDS			M:MIPI			E:eDP				
⑩	Interface:												
	N	Without control board			A	8Bit	B	16Bit		E	eDP	H	HDMI
	I	I2C Interface			R	RS232	S	SPI Interface		U	USB		
⑪	TS:												
	N	Without TS				T	Resistive touch panel			C	Capacitive touch panel (G-F-F)		
	G	Capacitive touch panel (G-G)					C1	Capacitive touch panel (G-F-F)+OCA					
	C2	Capacitive touch panel (G-F-F)+OCR					G1	Capacitive touch panel (G-G)+OCA					
	G2	Capacitive touch panel (G-G)+OCR					B	CTP+GG+USB					
⑫	Version:	X:Raspberry pi				V: Raspberry pi 3B+							
⑬	Special Code	#:Fit in with ROHS directive regulations											

## 2. General Specifications

Item	Dimension	Unit
Size	15.6	inch
Dot Matrix	1920 x RGB x 1080	dots
Module dimension	393.8(W) x 245.9(H)x 30.0 (D)	mm
Active area	344.16 x 193.59	mm
Pixel pitch	0.17925 (H) x 0.17925 (V)	mm
LCD type	TFT, Normally Black, Transmissive	
Viewing Angle	89/89/89/89	
Backlight Type	LED, Normally White	
Controller IC	LT6911C	
Electrical Interface (Logic)	DVI	
CTP Driver IC	ILI2511 or equivalent	
CTP Interface	USB	
CTP FW Version	0x06.0x00.0x00.0x00.0xFF.0xFF.0xFF.0xFF	
CTP Resolution	16384 * 16384	
With /Without TP	With CTP	
Surface	Glare	

\*Color tone slight changed by temperature and driving voltage.

### 3. Absolute Maximum Ratings

Item	Symbol	Min	Typ	Max	Unit
Operating Temperature	TOP	-20	—	+70	°C
Storage Temperature	TST	-30	—	+80	°C

Note: Device is subject to be damaged permanently if stresses beyond those absolute maximum ratings listed above

1. Temp.  $\leq 60^{\circ}\text{C}$ , 90% RH MAX. Temp.  $> 60^{\circ}\text{C}$ , Absolute humidity shall be less than 90% RH at  $60^{\circ}\text{C}$



## 4. Electrical Characteristics

### 4.1. Operating conditions:

Item	Symbol	Min	Typ	Max	Unit	Remark
Supply Voltage For LCM	VDD	11.5	12.0	12.5	V	—
Supply Current For LCM	IDD	—	1290	1935	mA	Note 1
LED Life Time	—	50,000	—	—	Hr	—

Note 1 : This value is test for VDD =12.0V , Ta=25°C only

Note 2 : Please make sure to support enough current

Note3 : CTP driver is base on the mouse driver program and through USB port connect to PC or embedded board.Can only support the single touch.

Note 4: The “LED life time” is defined as the module brightness decrease to 50% original brightness at Ta=25°C and IL =1000mA. The LED lifetime could be decreased if operating IL is larger than 1000mA.

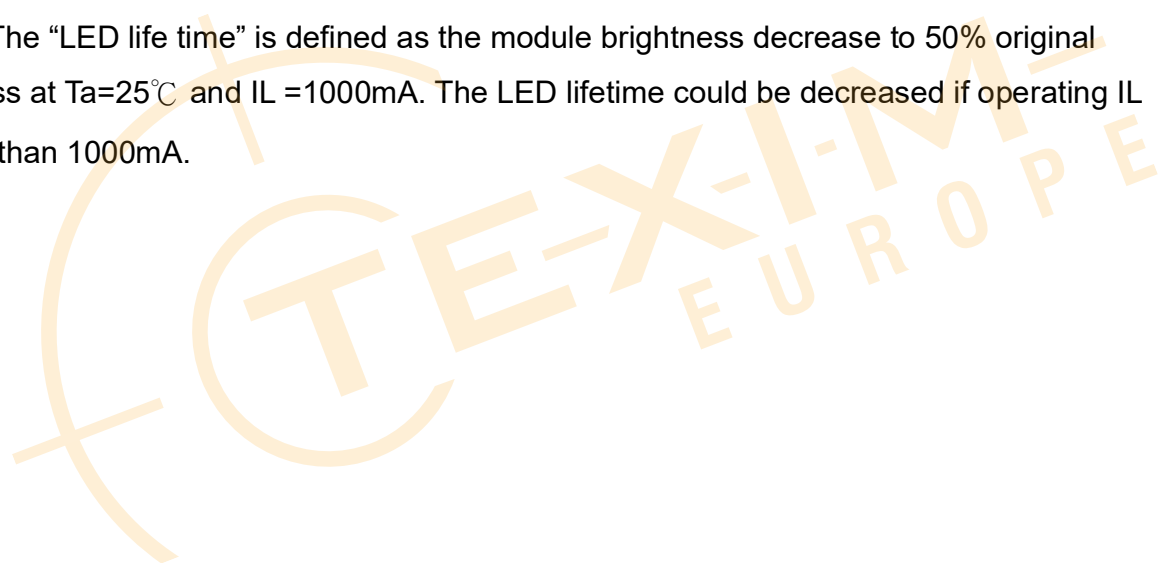

## 5. Optical Characteristics

Item	Symbol	Condition.	Min	Typ.	Max.	Unit	Remark	
Response time	Tr+ Tf	$\theta=0^\circ \cdot \Phi=0^\circ$	-	25	35	.ms	Note 3	
Contrast ratio	CR	At optimized viewing angle	600	800	-	-	Note 4,	
Color Chromaticity	White	Wx	$\theta=0^\circ \cdot \Phi=0$	0.263	0.313	0.363	Note 2,6,7	
		Wy		0.279	0.329	0.379		
Viewing angle	Hor.	$\Theta_R$	CR $\geq$ 10	85	89	-	Deg.	Note 1
		$\Theta_L$		85	89	-		
	Ver.	$\Phi_T$		85	89	-		
		$\Phi_B$		85	89	-		
Brightness	-	-	250	350	-	cd/m <sup>2</sup>	Center of display	
Uniformity	(U)	-	70	-	-	%	Note 5	

Ta=25±2°C

Note 1: Definition of viewing angle range

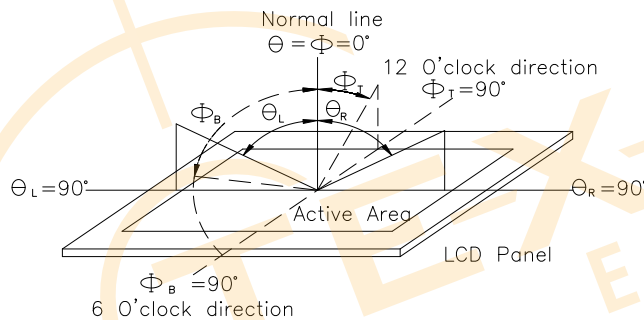

Fig 5.1. Definition of viewing angle

Note 2: Test equipment setup:

After stabilizing and leaving the panel alone at a driven temperature for 10 minutes, the measurement should be executed. Measurement should be executed in a stable, windless, and dark room. Optical specifications are measured by Topcon BM-7 or BM-5 luminance meter 1.0° field of view at a distance of 50cm and normal direction.

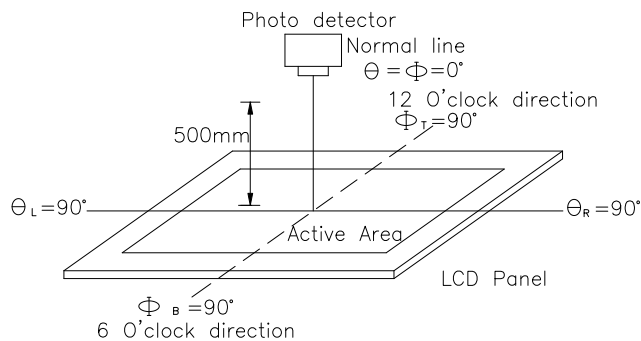
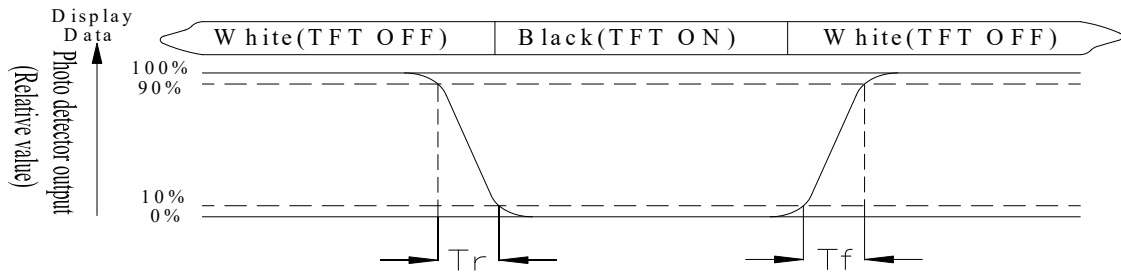

Fig 5.2. Optical measurement system setup

Note 3: Definition of Response time:

The response time is defined as the LCD optical switching time interval between “White” state and “Black” state. Rise time, Tr, is the time between photo detector output intensity changed

from 90% to 10%. And fall time,  $T_f$ , is the time between photo detector output intensity changed from 10% to 90%



Note 4: Definition of contrast ratio:

The contrast ratio is defined as the following expression.

$$\text{Contrast ratio (CR)} = \frac{\text{Luminance measured when LCD on the "White" state}}{\text{Luminance measured when LCD on the "Black" state}}$$

Note 5: Definition of Luminance Uniformity

Active area is divided into 9 measuring areas (reference the picture in below). Every measuring point is placed at the center of each measuring area.

$$\text{Luminance Uniformity (U)} = \text{Lmin/Lmax} \times 100\%$$

L = Active area length

W = Active area width

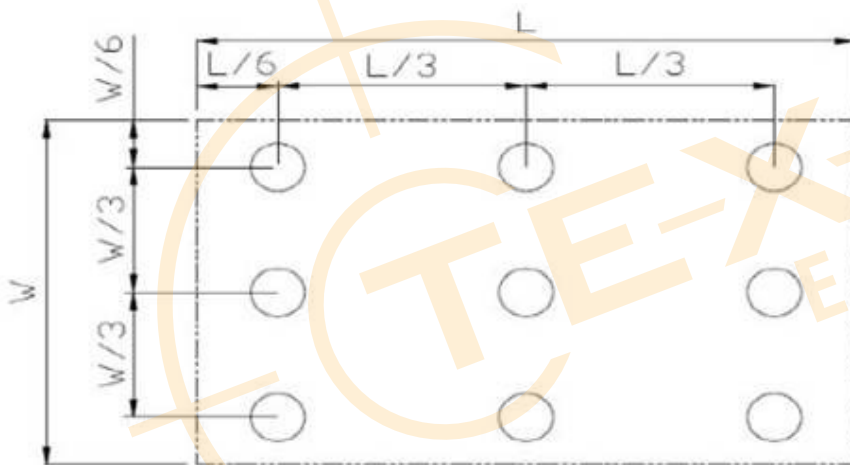

Fig 5.3. Definition of uniformity

Note 6: Definition of color chromaticity (CIE 1931)

Color coordinates measured at the center point of LCD

Note 7: Measured at the center area of the panel when all the input terminals of LCD panel are electrically opened.

## 6.Interface

### 6.1. LCM PIN Definition(CON3)

Pin No.	Symbol	Function	Remark
1	NC	No connection	
2	5V	Raspberry Pi:Power 5V	
3	GPIO02	Raspberry Pi:GPIO02	
4	5V	Raspberry Pi:Power 5V	
5	GPIO03	Raspberry Pi:GPIO03	
6	GND	Raspberry Pi:GND	
7	GPIO04	Raspberry Pi:GPIO04	
8	GPIO14	Raspberry Pi:GPIO14	
9	GND	Raspberry Pi:GND	
10	GPIO15	Raspberry Pi:GPIO15	
11	GPIO17	Raspberry Pi:GPIO17	
12	BL-PWM GPIO18	Raspberry Pi:GPIO18 (Backlight Enable)	Note 1 Note 2
13	GPIO27	Raspberry Pi:GPIO27	
14	GND	Raspberry Pi:GND	
15	GPIO22	Raspberry Pi:GPIO22	
16	GPIO23	Raspberry Pi:GPIO23	
17	NC	No connection	
18	GPIO24	Raspberry Pi:GPIO24	
19	GPIO10	Raspberry Pi:GPIO10	
20	GND	Raspberry Pi:GND	
21	GPIO09	Raspberry Pi:GPIO09	
22	GPIO25	Raspberry Pi:GPIO25	
23	GPIO11	Raspberry Pi:GPIO11	
24	GPIO08	Raspberry Pi:GPIO08	
25	GND	Raspberry Pi:GND	
26	GPIO07	Raspberry Pi:GPIO07	
27	ID_SD	Raspberry Pi:ID_SD	
28	ID_SC	Raspberry Pi:ID_SC	
29	GPIO05	Raspberry Pi:GPIO05	
30	GND	Raspberry Pi:GND	

31	GPIO06	Raspberry Pi:GPIO06	
32	GPIO12	Raspberry Pi:GPIO12	
33	GPIO13	Raspberry Pi:GPIO13	
34	GND	Raspberry Pi:GND	
35	GPIO19	Raspberry Pi:GPIO19	
36	GPIO16	Raspberry Pi:GPIO16	
37	GPIO26	Raspberry Pi:GPIO26	
38	GPIO20	Raspberry Pi:GPIO20	
39	GND	Raspberry Pi:GND	
40	GPIO21	Raspberry Pi:GPIO21	

Note 1: Adjust the PWM signal in order to control LED Backlight's brightness. The higher the duty cycle, the lower the brightness.

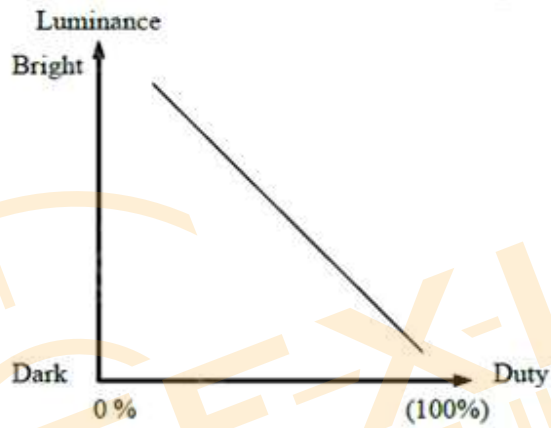

Note 2: PWM signal operation frequency is 190Hz

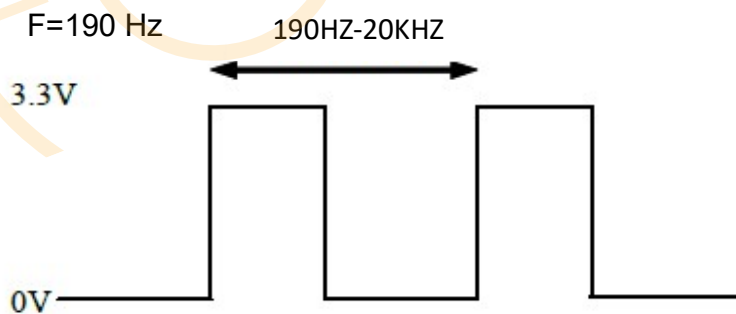

6.2. (CON4)

Pin No.	Symbol	Function	Remark
1	3.3V	TFT Module Power limit can only output 3.3V,100mA	Note3
2	5V	Raspberry Pi:Power 5V	
3	GPIO02	Raspberry Pi:GPIO02	
4	5V	Raspberry Pi:Power 5V	
5	GPIO03	Raspberry Pi:GPIO03	
6	GND	Raspberry Pi:GND	
7	GPIO04	Raspberry Pi:GPIO04	
8	GPIO14	Raspberry Pi:GPIO14	
9	GND	Raspberry Pi:GND	
10	GPIO15	Raspberry Pi:GPIO15	
11	GPIO17	Raspberry Pi:GPIO17	
12	BL-PWM GPIO18	Raspberry Pi:GPIO18 (Backlight Enable)	
13	GPIO27	Raspberry Pi:GPIO27	
14	GND	Raspberry Pi:GND	
15	GPIO22	Raspberry Pi:GPIO22	
16	GPIO23	Raspberry Pi:GPIO23	
17	3.3V	TFT Module Power limit can only output 3.3V,100mA	Note3
18	GPIO24	Raspberry Pi:GPIO24	
19	GPIO10	Raspberry Pi:GPIO10	
20	GND	Raspberry Pi:GND	
21	GPIO09	Raspberry Pi:GPIO09	
22	GPIO25	Raspberry Pi:GPIO25	
23	GPIO11	Raspberry Pi:GPIO11	
24	GPIO08	Raspberry Pi:GPIO08	
25	GND	Raspberry Pi:GND	
26	GPIO07	Raspberry Pi:GPIO07	
27	ID_SD	Raspberry Pi:ID_SD	
28	ID_SC	Raspberry Pi:ID_SC	
29	GPIO05	Raspberry Pi:GPIO05	
30	GND	Raspberry Pi:GND	
31	GPIO06	Raspberry Pi:GPIO06	
32	GPIO12	Raspberry Pi:GPIO12	

33	GPIO13	Raspberry Pi:GPIO13	
34	GND	Raspberry Pi:GND	
35	GPIO19	Raspberry Pi:GPIO19	
36	GPIO16	Raspberry Pi:GPIO16	
37	GPIO26	Raspberry Pi:GPIO26	
38	GPIO20	Raspberry Pi:GPIO20	
39	GND	Raspberry Pi:GND	
40	GPIO21	Raspberry Pi:GPIO21	

Note3: The 3.3V supply current is limited; please pay special attention to use

### 6.3. DVI

Pin No.	Symbol	I/O	Function	Remark
1	Rx2+	I	Channel-2 positive receiver input; low-voltage signal differential- input pair.	
2	GND	P	Ground	
3	Rx2-	I	Channel-2 negative receiver input; low-voltage signal differential- input pair.	
4	Rx1+	I	Channel-1 positive receiver input; low-voltage signal differential- input pair.	
5	GND	P	Ground	
6	Rx1-	I	Channel-1 negative receiver input; low-voltage signal differential- input pair.	
7	Rx0+	I	Channel-0 positive receiver input; low-voltage signal differential- input pair.	
8	GND	P	Ground	
9	Rx0-	I	Channel-0 negative receiver input; low-voltage signal differential- input pair.	
10	RxC+	I	Clock positive receiver input; low-voltage signal differential- input pair.	
11	GND	P	Ground	
12	RxC-	I	Clock negative receiver input; low-voltage signal differential- input pair.	
13-14	NC	-	No connection	
15	SCL	I/O	DDC(Data Display Channel) Clock	
16	SDA	I/O	DDC(Data Display Channel) Data	
17	GND	P	Ground	
18	HDMI_5V	P	Power Supply	
19	Detect	I/O	Hot plug detect	

I: input, O: output, P: Power

#### 6.4. USB

Pin No	Symbol	Function	Remark
A1	GND	Power Ground	
A4	NC	No connection	
A5	NC	No connection	
A6	D+	Data line +	
A7	D-	Data line -	
A8	NC	No connection	
A9	NC	No connection	
A12	GND	Power Ground	
B12	GND	Power Ground	
B9	NC	No connection	
B8	NC	No connection	
B7	D-	Data line -	
B6	D+	Data line +	
B5	NC	No connection	
B4	NC	No connection	
B1	GND	Power Ground	

### 6.5. PW\_12V

Pin No	Symbol	Function	Remark
A1	GND	Power Ground	
A4	VBUS	Power 12V	
A5	CC1	Configuration channel	
A6	NC	No connection	
A7	NC	No connection	
A8	NC	No connection	
A9	VBUS	Power 12V	
A12	GND	Power Ground	
B12	GND	Power Ground	
B9	VBUS	Power 12V	
B8	NC	No connection	
B7	NC	No connection	
B6	NC	No connection	
B5	CC2	Configuration channel	
B4	VBUS	Power 12V	
B1	GND	Power Ground	

# 7. Reliability

## Content of Reliability Test (Wide temperature, -20°C~70°C)

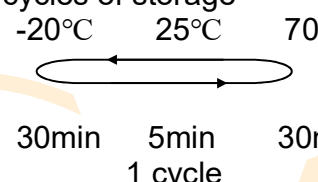
Environmental Test			
Test Item	Content of Test	Test Condition	Note
High Temperature storage	Endurance test applying the high storage temperature for a long time.	80°C 200hrs	2
Low Temperature storage	Endurance test applying the low storage temperature for a long time.	-30°C 200hrs	1,2
High Temperature Operation	Endurance test applying the electric stress (Voltage & Current) and the thermal stress to the element for a long time.	70°C 200hrs	2
Low Temperature Operation	Endurance test applying the electric stress under low temperature for a long time.	-20°C 200hrs	1,2
High Temperature/ Humidity Operation	The module should be allowed to stand at 60°C,90%RH max	60°C,90%RH 96hrs	1,2
Thermal shock resistance	The sample should be allowed stand the following 10 cycles of storage  -20°C    25°C    70°C 30min    5min    30min 1 cycle	-20°C/70°C 10 cycles	2
Vibration test	Endurance test applying the vibration during transportation and using.	Total fixed amplitude : 1.5mm Vibration Frequency : 10~55Hz One cycle 60 seconds to 3 directions of X,Y,Z for Each 15 minutes	3
Static electricity test	Endurance test applying the electric stress to the terminal.	VS=±6KV(contact), ±8KV(air), RS=330Ω CS=150pF 10 times	4

Note1: No dew condensation to be observed.

Note2: The function test shall be conducted after 4 hours storage at the normal Temperature and humidity after remove from the test chamber.

Note3: The packing have to including into the vibration testing.

Note4: Endurance test applying the electric stress to the finished product housing

# 8. Contour Drawing

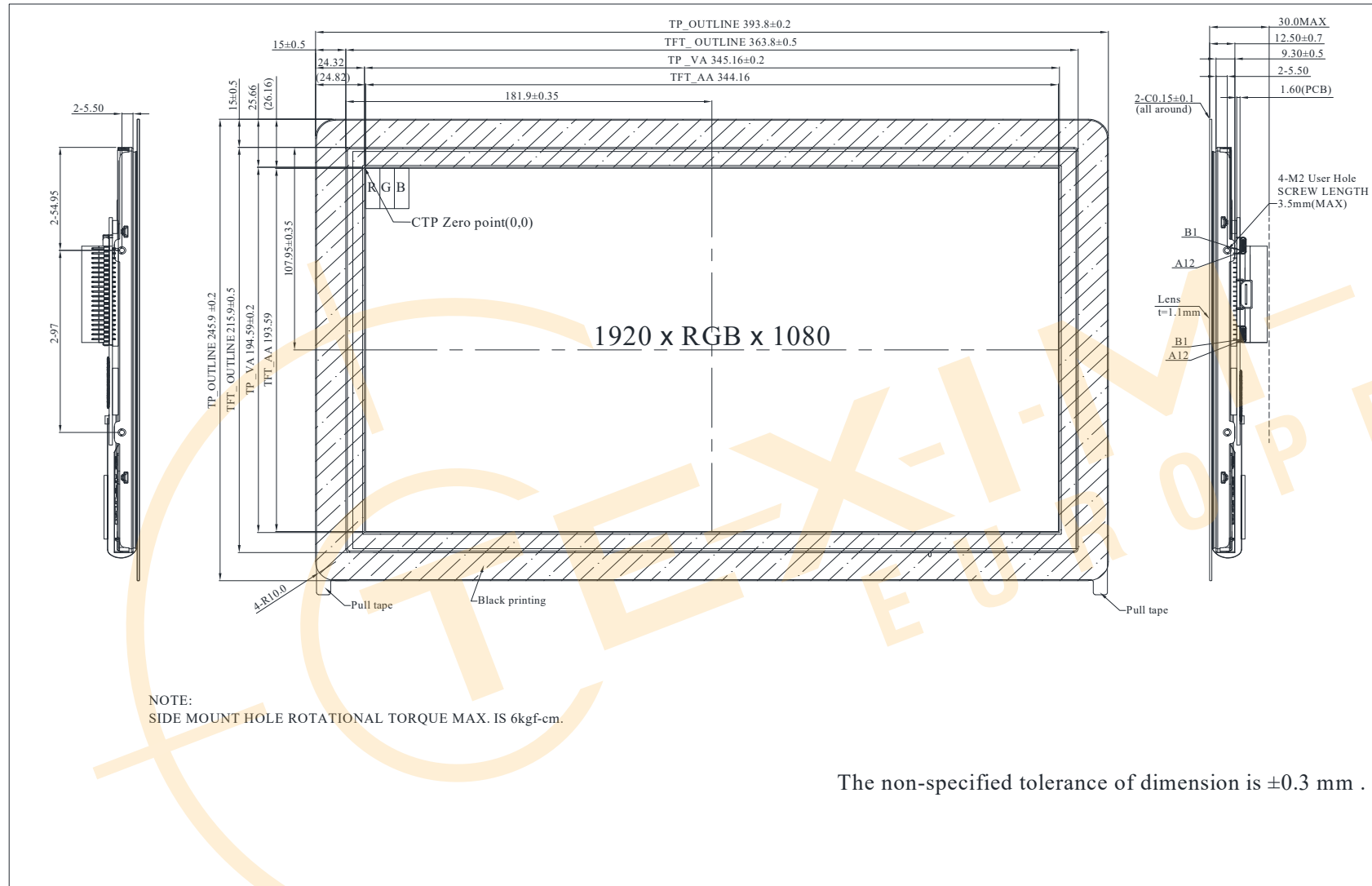

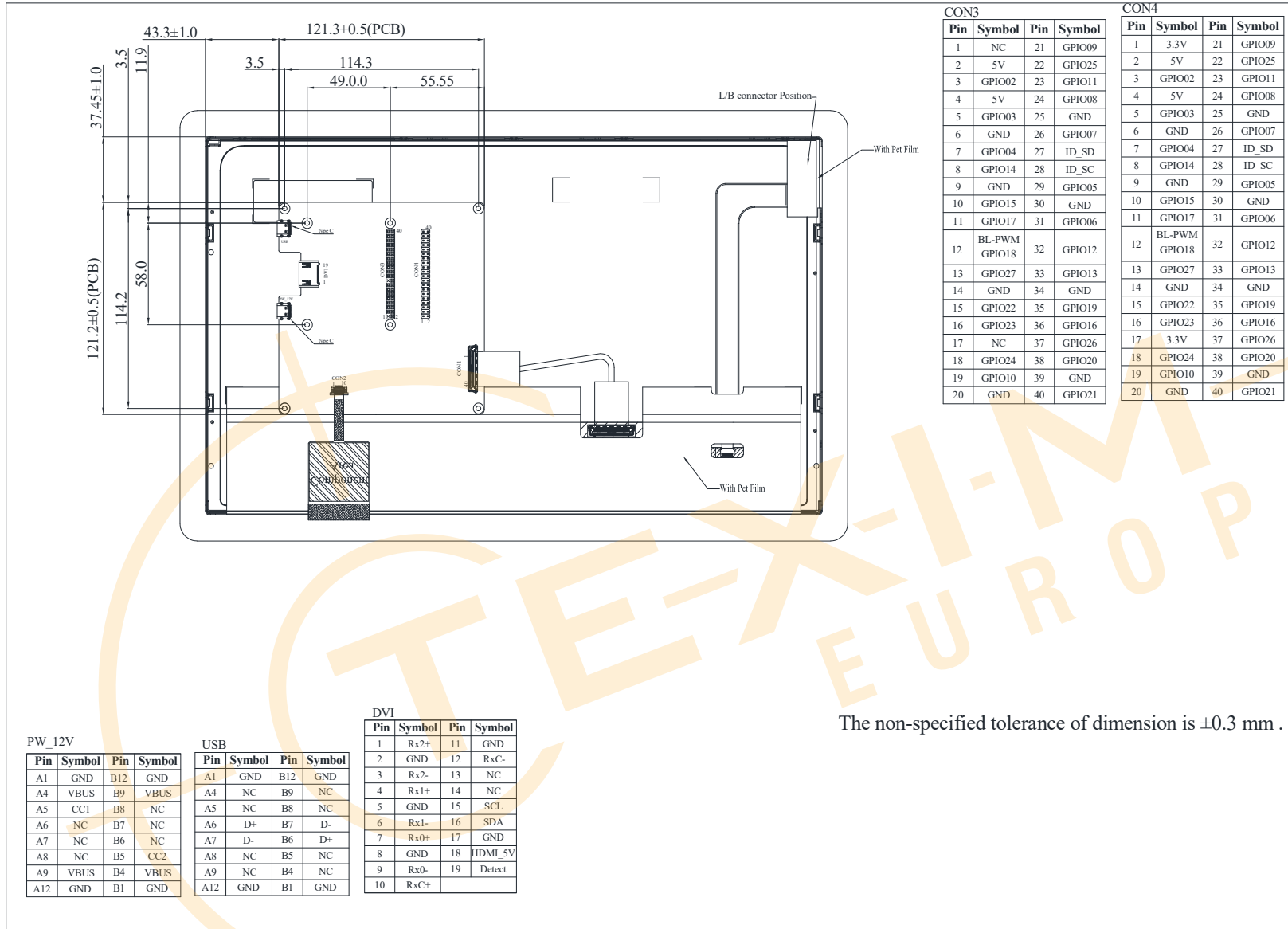

CON3				CON4			
Pin	Symbol	Pin	Symbol	Pin	Symbol	Pin	Symbol
1	NC	21	GPIO09	1	3.3V	21	GPIO09
2	5V	22	GPIO25	2	5V	22	GPIO25
3	GPIO02	23	GPIO11	3	GPIO02	23	GPIO11
4	5V	24	GPIO08	4	5V	24	GPIO08
5	GPIO03	25	GND	5	GPIO03	25	GND
6	GND	26	GPIO07	6	GND	26	GPIO07
7	GPIO04	27	ID_SD	7	GPIO04	27	ID_SD
8	GPIO14	28	ID_SC	8	GPIO14	28	ID_SC
9	GND	29	GPIO05	9	GND	29	GPIO05
10	GPIO15	30	GND	10	GPIO15	30	GND
11	GPIO17	31	GPIO06	11	GPIO17	31	GPIO06
12	BL-PWM GPIO18	32	GPIO12	12	BL-PWM GPIO18	32	GPIO12
13	GPIO27	33	GPIO13	13	GPIO27	33	GPIO13
14	GND	34	GND	14	GND	34	GND
15	GPIO22	35	GPIO19	15	GPIO22	35	GPIO19
16	GPIO23	36	GPIO16	16	GPIO23	36	GPIO16
17	NC	37	GPIO26	17	3.3V	37	GPIO26
18	GPIO24	38	GPIO20	18	GPIO24	38	GPIO20
19	GPIO10	39	GND	19	GPIO10	39	GND
20	GND	40	GPIO21	20	GND	40	GPIO21

PW\_12V

Pin	Symbol	Pin	Symbol
A1	GND	B12	GND
A4	VBUS	B9	VBUS
A5	CC1	B8	NC
A6	NC	B7	NC
A7	NC	B6	NC
A8	NC	B5	CC2
A9	VBUS	B4	VBUS
A12	GND	B1	GND

USB

Pin	Symbol	Pin	Symbol
A1	GND	B12	GND
A4	NC	B9	NC
A5	NC	B8	NC
A6	D+	B7	D-
A7	D-	B6	D+
A8	NC	B5	NC
A9	NC	B4	NC
A12	GND	B1	GND

DVI

Pin	Symbol	Pin	Symbol
1	Rx2+	11	GND
2	GND	12	RxC-
3	Rx2-	13	NC
4	Rx1+	14	NC
5	GND	15	SCL
6	Rx1-	16	SDA
7	Rx0+	17	GND
8	GND	18	HDML_5V
9	Rx0-	19	Detect
10	RxC+		

The non-specified tolerance of dimension is  $\pm 0.3$  mm .

## **9. Inspection Specification**

### **9.1. Description**

These inspection standards shall be applied to LCD Module supplied by Winstar. This model is only used for Industry product. If there are any other product applications such as handwriting recognition, Medical use, Automobile, Aerospace use and so on, the specification should be negotiated separately.

### **9.2. The environmental condition of inspection**

The environmental condition and visual inspection shall be conducted as below.

- (1) Ambient temperature : 15~25°C
- (2) Humidity : 25~75 %RH
- (3) External appearance inspection shall be conducted by using a single 20W fluorescent lamp or equivalent illumination.
- (4) Panel visual inspection on the operation condition for cosmetic shall be conducted at the distance 35cm or more between the LCD module and eyes of inspector.  
Ambient Illumination : 300 ~ 500 Lux for external appearance inspection  
Ambient Illumination : 100 ~ 200 Lux for light on inspection
- (5) The viewing angle :
  - a) 15 degree to the front surface of display panel in vertical direction.
  - b) 45 degree to the front surface of display panel in horizontal direction.
- (6) ND filter shall be conducted at the dist

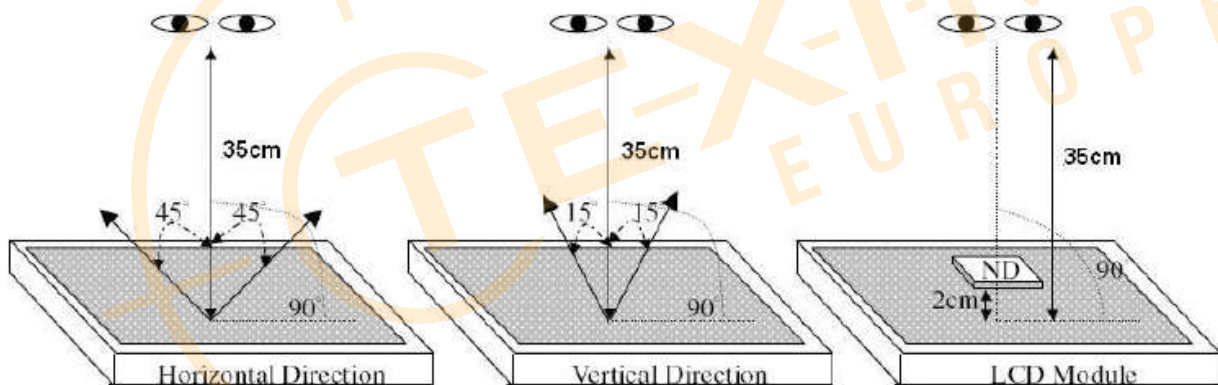

### 9.3. Classification of defects

Defects are classified two types, major defect and minor defect according to the defect. And, the definition of defects is classified as below.

(1) Major defect

Any defect may result in functional failure, or reduce the usability of product for its purpose. For example, electrical failure, deformation and etc..

(2) Minor defect

A defect that is not to reduce the usability of product for its intended purpose and un-uniformity, dot defect and etc..

The criteria on major or minor judgment will be according with the classification of defects, and any defects out of active area, are not considered as a defect or counted.

### 9.4. Inspection Criteria

(1) Definition of dot defect induced from the panel inside

- a. Bright dot :Dots appear bright and unchanged in size in which module is displaying under black pattern.
- b. Dark dot :Dots appear dark and unchanged in size in which module is displaying under pure red,green, blue, white picture.
- c. 2 Full dot adjacent = 1pair.
- d. Picture :

(a) Full dot



(b) 2 Full dot adjacent



(c) Spot defect

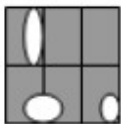

(2) Display Inspection standards when power on.

Items		Acceptable count
Full Bright dot	Random	$N \leq 2$
	2 dots adjacent	$N \leq 1$
	3 dots adjacent or more	$N \leq 0$
Full Dark dot	Random	$N \leq 3$
	2 dots adjacent	$N \leq 1$
	3 dots adjacent or more	$N \leq 0$
Total full bright and full dark dot		$N \leq 5$
Foreign Black/White/Bright Spot		$D \leq 0.15\text{mm}$ , Ignore $0.15 < D \leq 0.5\text{ mm}$ , $N \leq 4$
Foreign Black/White/Bright Line		$W \leq 0.05\text{mm}$ , Ignore $0.05 < W \leq 0.1\text{ mm}$ , $0.3 < L \leq 2.0\text{ mm}$ , $N \leq 4$
Polarizer	Scratches	$W \leq 0.05\text{mm}$ , Ignore $0.05 < W \leq 0.1\text{ mm}$ , $0.3 < L \leq 2.0\text{ mm}$ , $N \leq 4$
	Dent /Bubble	Avg. $0.15 < D \leq 0.5\text{ mm}$ , $N \leq 4$
Distance	Minimum Distance Between Full Bright dots	$L \geq 10\text{mm}$
	Minimum Distance Between Full Dark dots	$L \geq 10\text{mm}$
Display failure (V-line/H-line/Cross line etc.)		Not allowable
Mura	Not visible through 6% ND filter in 50% gray or judge by limit sample if necessary	

**9.5. External Appearance Inspection Criteria (Power off)**

Item	Contents	
Screw	Parts mounting, incomplete assembly, deformation, oxidized, crooked or rusty is not permitted.	
CCFL cable (For CCFL Model)	Cable not continuous · Break-off · Connector Burn-off /Break-off	
Metal frame (Bezel)	Scratch	*Noticeable scratch and exfoliation coating are not permitted. *The oxidized metal is not permitted.
	Incomplete assembly is not permitted.	
Backlight	Scratch	The scratch which may causes a problem in practical use is not permitted.
	Break-off	Breaking off is not permitted.
	Crack	The crack is not permitted.
Polarizer	Scratches	$W \leq 0.05\text{mm}$ , Ignore $0.05 < W \leq 0.1 \text{ mm}$ , $0.3 < L \leq 10.0 \text{ mm}$ , $N \leq 4$
	Dent/Bubble	Avg. $0.15 < D \leq 0.5 \text{ mm}$ , $N \leq 4$
	Stain	The stain on polarizer, which can't be wiped off, is not permitted.
Tape/Label	Incorrect position, missed label is not permitted.	
Connector	Oxidized/rusty connector is not permitted.	
Outline size	Spec. out is not permitted.	

\*Note: If any specific defect is not included in the above defect table, this defect should be judged by INX/ODM/Brand customer discussion.

Note.1

$$D = (a+b)/2$$

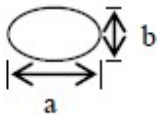

Note.2

W: width, L : length

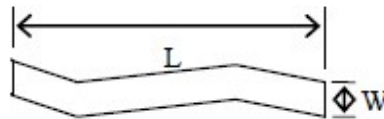

### 9.6. Classification of defects

Inspection Item	Criteria and Description	Defect type
Vertical line	Signal input, vertical line off or irregular V-line appears	major
Horizontal line	Signal input, horizontal line off or irregular H-line appears	major
Cross line	Pattern signal input, a correct display is not obtained	major
No display	Signal input, display is dead	major
Irregular display	Pattern signal input, a correct display is not obtained	major
Dots defect	Exceed specified standards	minor
Scratch and Dent on polarizer	Exceed specified standards	minor
Foreign material	Exceed specified standards	minor
Mura	Non-uniformity is appeared in display	minor
Polarizer bubble	Exceed specified standards	minor





winstar

**LCM Sample Estimate Feedback Sheet**

Module Number : \_\_\_\_\_

Page: 1

**1、Panel Specification :**

- 1. Panel Type :  Pass  NG , \_\_\_\_\_
- 2. View Direction :  Pass  NG , \_\_\_\_\_
- 3. Numbers of Dots :  Pass  NG , \_\_\_\_\_
- 4. View Area :  Pass  NG , \_\_\_\_\_
- 5. Active Area :  Pass  NG , \_\_\_\_\_
- 6. Operating Temperature :  Pass  NG , \_\_\_\_\_
- 7. Storage Temperature :  Pass  NG , \_\_\_\_\_
- 8. Others : \_\_\_\_\_

**2、Mechanical**

- 1. PCB Size :  Pass  NG , \_\_\_\_\_
- 2. Frame Size :  Pass  NG , \_\_\_\_\_
- 3. Material of Frame :  Pass  NG , \_\_\_\_\_
- 4. Connector Position :  Pass  NG , \_\_\_\_\_
- 5. Fix Hole Position :  Pass  NG , \_\_\_\_\_
- 6. Backlight Position :  Pass  NG , \_\_\_\_\_
- 7. Thickness of PCB :  Pass  NG , \_\_\_\_\_
- 8. Height of Frame to PCB :  Pass  NG , \_\_\_\_\_
- 9. Height of Module :  Pass  NG , \_\_\_\_\_
- 10. Others :  Pass  NG , \_\_\_\_\_

**3、Relative Hole Size :**

- 1. Pitch of Connector :  Pass  NG , \_\_\_\_\_
- 2. Hole size of Connector :  Pass  NG , \_\_\_\_\_
- 3. Mounting Hole size :  Pass  NG , \_\_\_\_\_
- 4. Mounting Hole Type :  Pass  NG , \_\_\_\_\_
- 5. Others :  Pass  NG , \_\_\_\_\_

**4、Backlight Specification :**

- 1. B/L Type :  Pass  NG , \_\_\_\_\_
- 2. B/L Color :  Pass  NG , \_\_\_\_\_
- 3. B/L Driving Voltage (Reference for LED) :  Pass  NG , \_\_\_\_\_
- 4. B/L Driving Current :  Pass  NG , \_\_\_\_\_
- 5. Brightness of B/L :  Pass  NG , \_\_\_\_\_
- 6. B/L Solder Method :  Pass  NG , \_\_\_\_\_
- 7. Others :  Pass  NG , \_\_\_\_\_

>> **Go to page 2** <<



Winstar      Module Number : \_\_\_\_\_

Page: 2

**5、Electronic Characteristics of Module :**

- |                              |                               |                               |       |
|------------------------------|-------------------------------|-------------------------------|-------|
| 1. Input Voltage :           | <input type="checkbox"/> Pass | <input type="checkbox"/> NG , | _____ |
| 2. Supply Current :          | <input type="checkbox"/> Pass | <input type="checkbox"/> NG , | _____ |
| 3. Driving Voltage for LCD : | <input type="checkbox"/> Pass | <input type="checkbox"/> NG , | _____ |
| 4. Contrast for LCD :        | <input type="checkbox"/> Pass | <input type="checkbox"/> NG , | _____ |
| 5. B/L Driving Method :      | <input type="checkbox"/> Pass | <input type="checkbox"/> NG , | _____ |
| 6. Negative Voltage Output : | <input type="checkbox"/> Pass | <input type="checkbox"/> NG , | _____ |
| 7. Interface Function :      | <input type="checkbox"/> Pass | <input type="checkbox"/> NG , | _____ |
| 8. LCD Uniformity :          | <input type="checkbox"/> Pass | <input type="checkbox"/> NG , | _____ |
| 9. ESD test :                | <input type="checkbox"/> Pass | <input type="checkbox"/> NG , | _____ |
| 10. Others :                 | <input type="checkbox"/> Pass | <input type="checkbox"/> NG , | _____ |

**6、Summary :**

Sales signature : \_\_\_\_\_

Customer Signature : \_\_\_\_\_

Date :      /      /      \_\_\_\_\_

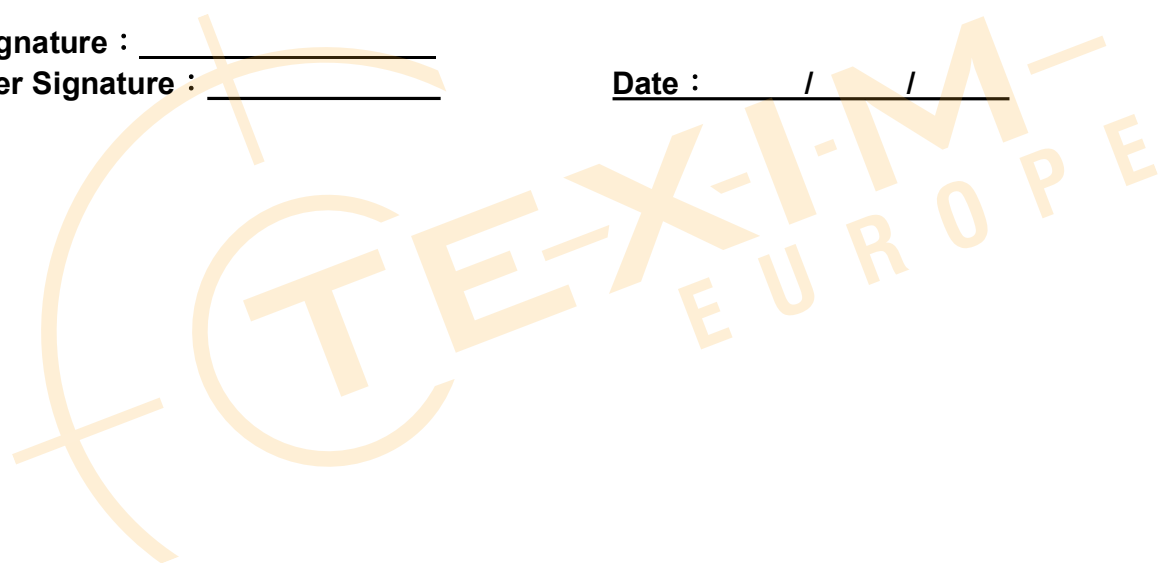

## **Disclaimer**

ALL PRODUCTS, PRODUCT SPECIFICATIONS AND DATA ARE SUBJECT TO CHANGE WITHOUT NOTICE TO IMPROVE RELIABILITY, FUNCTION OR DESIGN OR OTHERWISE.

Texim Europe B.V. its affiliates, agents, and employees, and all persons acting on its or their behalf (collectively, "Texim"), disclaim any and all liability for any errors, inaccuracies or incompleteness contained in any datasheet or in any other disclosure relating to any product.

Texim makes no warranty, representation or guarantee regarding the suitability of the products for any particular purpose or the continuing production of any product.

It is the customer's responsibility to validate that a particular product with the properties described in the product specification is suitable for use in a particular application.

Parameters provided in datasheets and / or specifications may vary in different applications and performance may vary over time.

All operating parameters, including typical parameters, must be validated for each customer application by the customer's technical experts.

Please contact us if you have any questions about the contents of the datasheet.

This may not be the latest version of the datasheet. Please check with us if a later version is available.

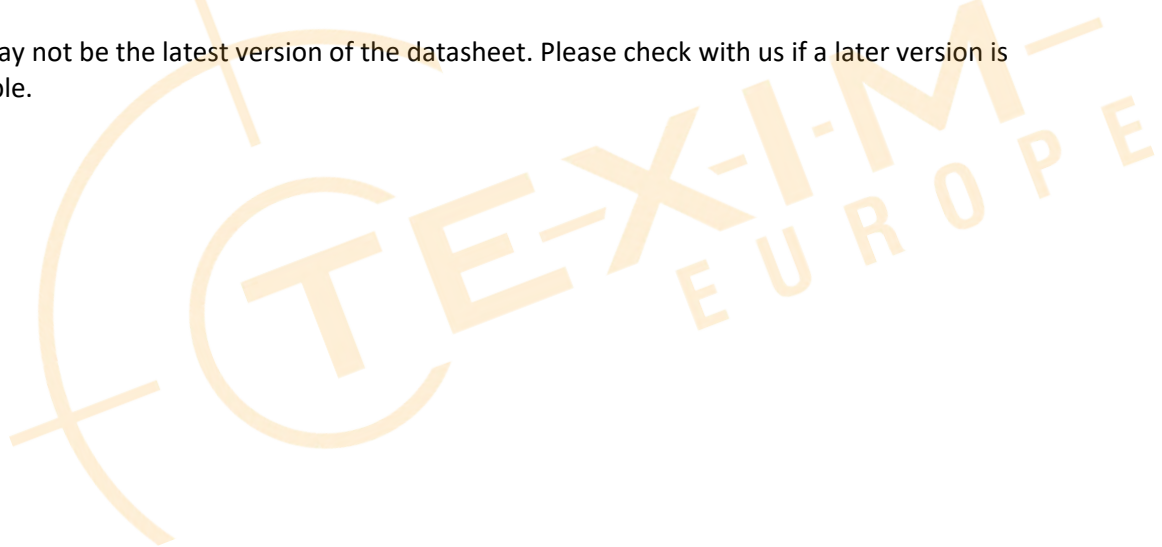



## Headquarters & Warehouse

Elektrostraat 17  
 NL-7483 PG Haaksbergen  
 The Netherlands

T: +31 (0)53 573 33 33  
 E: info@texim-europe.com  
 Homepage: www.texim-europe.com



### The Netherlands

Elektrostraat 17  
 NL-7483 PG Haaksbergen

T: +31 (0)53 573 33 33  
 E: nl@texim-europe.com



### Belgium

Zuiderlaan 14, box 10  
 B-1731 Zellik

T: +32 (0)2 462 01 00  
 E: belgium@texim-europe.com



### UK & Ireland

St Mary's House, Church Lane  
 Carlton Le Moorland  
 Lincoln LN5 9HS

T: +44 (0)1522 789 555  
 E: uk@texim-europe.com



### Germany

Bahnhofstrasse 92  
 D-25451 Quickborn

T: +49 (0)4106 627 07-0  
 E: germany@texim-europe.com



### Germany

Martin-Kollar-Strasse 9  
 D-81829 München

T: +49 (0)89 436 086-0  
 E: muenchen@texim-europe.com



### Austria

Martin-Kollar-Strasse 9  
 D-81829 München

T: +49 (0)89 436 086-0  
 E: austria@texim-europe.com



### Nordic

Stockholmsgade 45  
 2100 Copenhagen

T: +45 88 20 26 30  
 E: nordic@texim-europe.com



### Italy

Martin-Kollar-Strasse 9  
 D-81829 München

T: +49 (0)89 436 086-0  
 E: italy@texim-europe.com