

Chefree Technology Corp.

TFT COLOR LCD MODULE

MODEL: CF101ELHLWH-CA2-U

(Complied with RoHS)

**WXGA
LVDS interface**

Version: P01

Customer : _____	
Approved By : _____	Distributed by:  www.texim-europe.com
Date: _____	

CHEFREE		
APPROVAL	CHECKER	PREPARE
Tim	Mark	Benson

C O N T E N T S

1. RECORD OF REVISION	1
2. MECHANICAL SPECIFICATIONS	2
3. OUTLINE DIMENSIONS	3
4. INTERFACE PIN CONNECTION	4
5. BLOCK DIAGRAM	5
6. ABSOLUTE MAXIMUM RATINGS	6
7. ELECTRICAL CHARACTERISTICS	7
8. OPTICAL CHARACTERISTICS	9
9. TOUCH PANEL SPECIFICATIONS	12
10. TIMING SPECIFICATIONS	13
11. RELIABILITY TEST	16
12. PRECAUTIONS FOR USE	17



1. RECORD OF REVISION

Rev	DATE	PAGE	SUMMARY
P00	2024.12.10	ALL	Preliminary specification was issued
P01	2026.04.08	-	BIAS power chip changed to new part because EOL Original: ANX6623AAQ Alternative: HA5266DD

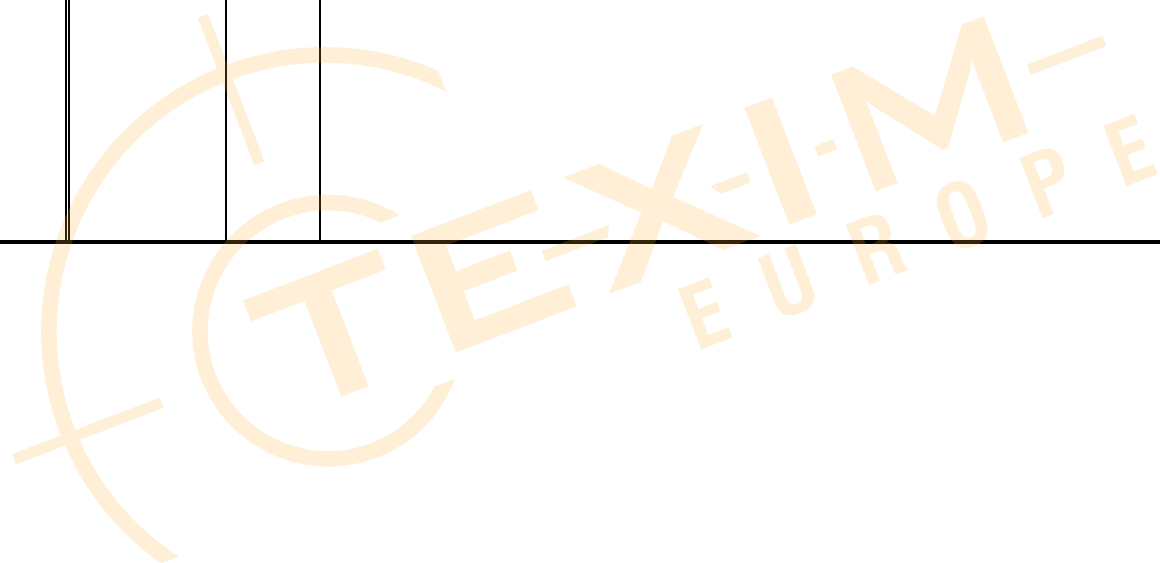

2. MECHANICAL SPECIFICATIONS

(1)	Number of Dots	1280(R.G.B) x 800
(2)	Module Size(mm)	253.96(H) x 172.6(V) x 10.3 (D)
(3)	Active Area(mm)	216.96(H) x 135.60(V)
(4)	Pixel Pitch(mm)	0.1695(H) x 0.1695(V)
(5)	LCD Model	TFT, Transmissive, Normally Black
(6)	Backlight Color	White
(7)	Viewing Direction	Wide View Angle
(8)	Electrical Interface	LVDS Interface
(9)	Color Configuration	R.G.B Vertical Stripe
(10)	Touch Panel Mode	Built in EETI 81W46 Controller
(11)	Module Weight(g)	470±5%



3. OUTLINE DIMENSIONS

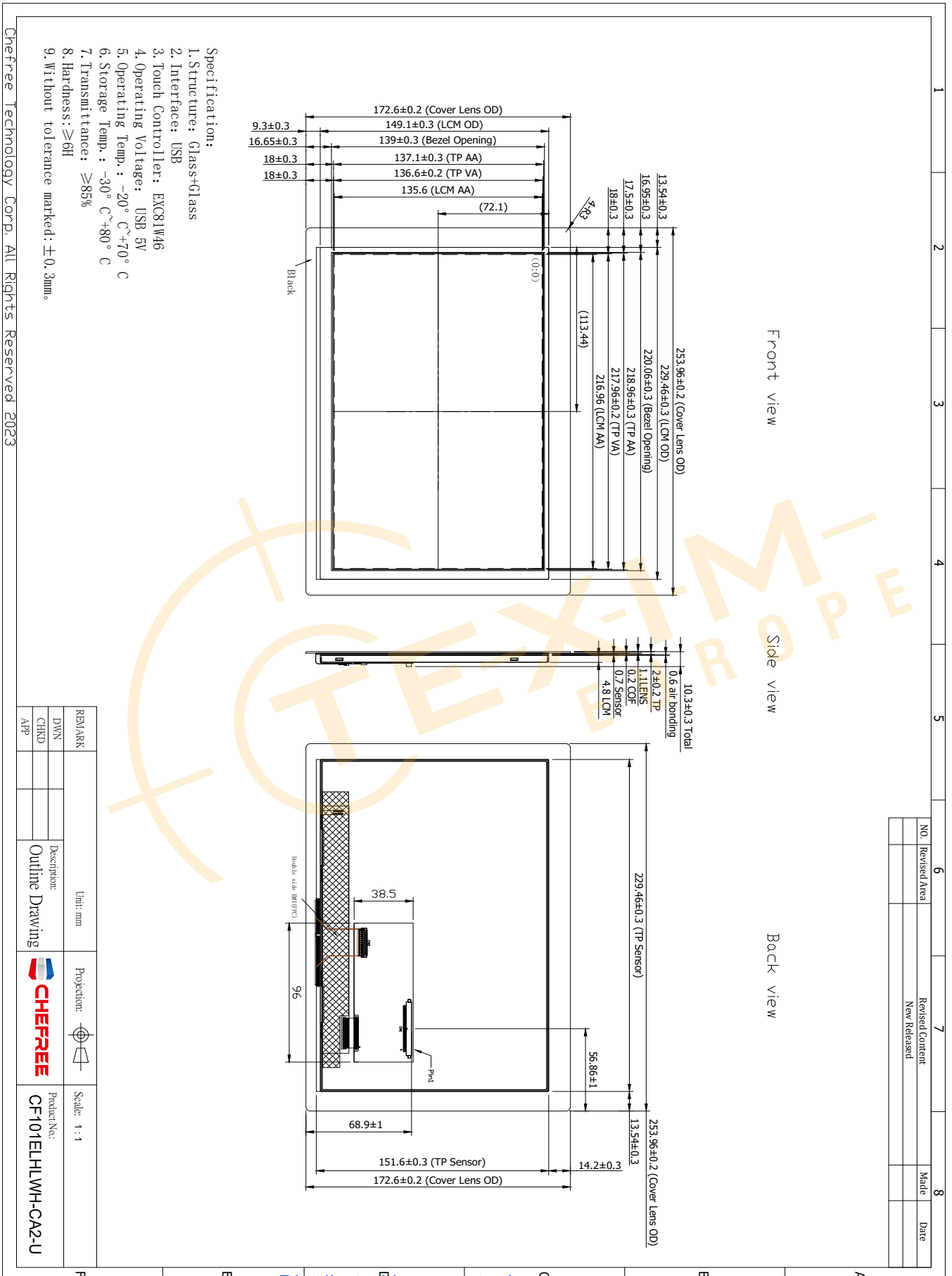

4. INTERFACE PIN CONNECTION

4.1 TFT LCM PANEL PIN DEFINE

CN1 Connector : STM MSBK2407P30 RF:HB or Equivalent

PIN No.	Symbol	I/O	Description	Remark
1	GND	P	Ground	
2	GND	P	Ground	
3	EN	I	Enable Control for Backlight	
4	PWM	I	Brightness Control for Backlight	
5	VLED	P	Power Supply for LED Backlight	
6	VLED	P	Power Supply for LED Backlight	
7	VDD	P	Power Supply for Digital Circuit (3.3V)	
8	NC	-	No connection	
9	NC	-	No connection	
10	GND	P	Ground	
11	RxIN0-	I	Negative LVDS Differential Data Input	
12	RxIN0+	I	Positive LVDS Differential Data Input	
13	GND	P	Ground	
14	RxIN1-	I	Negative LVDS Differential Data Input	
15	RxIN1+	I	Positive LVDS Differential Data Input	
16	GND	P	Ground	
17	RxIN2-	I	Negative LVDS Differential Data Input	
18	RxIN2+	I	Positive LVDS Differential Data Input	
19	GND	P	Ground	
20	RxCLK-	I	Negative LVDS Differential Clock Input	
21	RxCLK+	I	Positive LVDS Differential Clock Input	
22	GND	P	Ground	
23	RxIN3-	I	Negative LVDS Differential Data Input	
24	RxIN3+	I	Positive LVDS Differential Data Input	
25	NC	-	No connection	
26	NC	-	No connection	
27	VCC	P	Power Supply for PCAP(5V)	
28	D-	I	Data-	
29	D+	I	Data+	
30	GND	P	Ground	

Note : 'P' stand for Power, 'I' stand for Input

5. BLOCK DIAGRAM

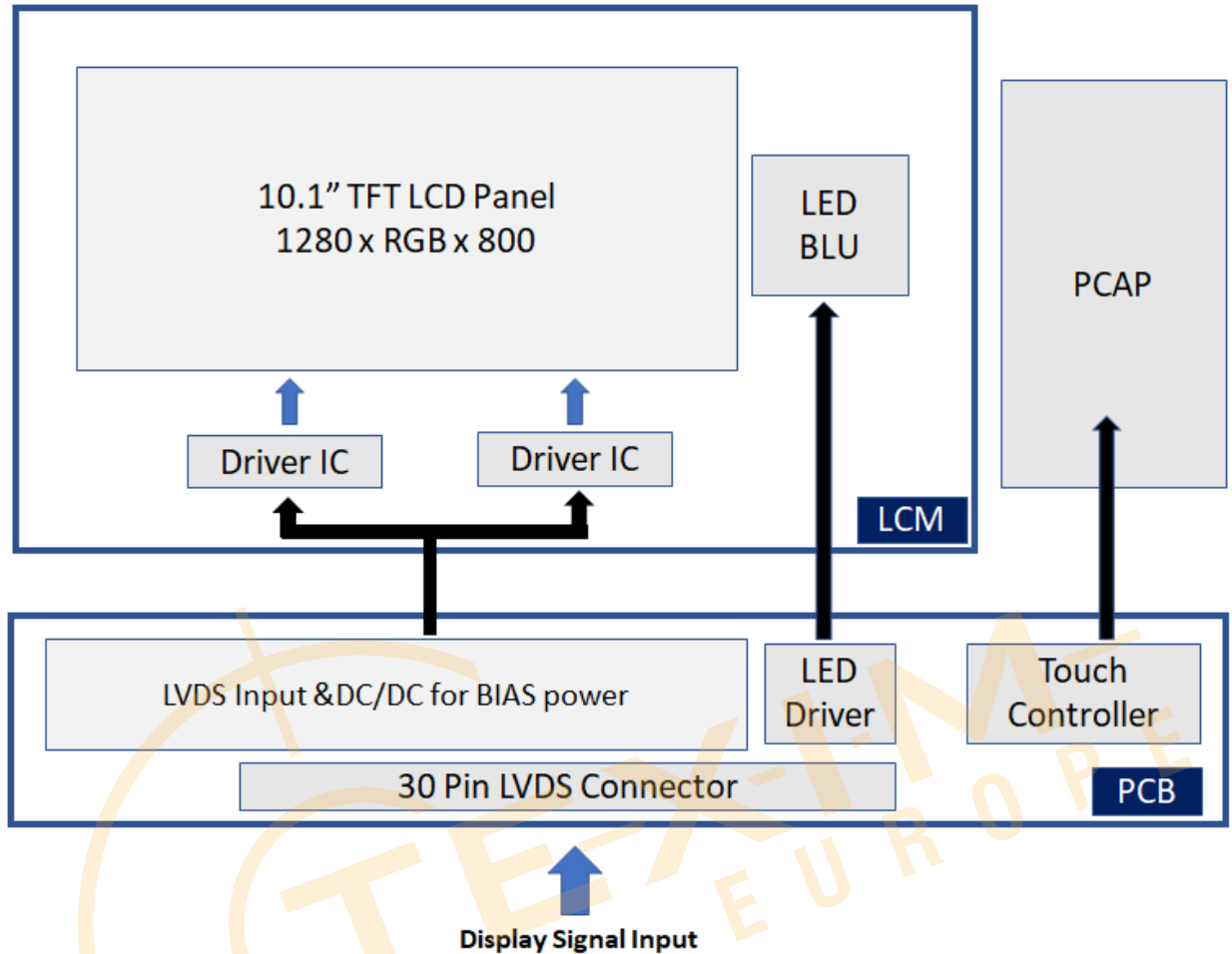

6. ABSOLUTE MAXIMUM RATINGS

6.1 ELECTRICAL ABSOLUTE MAXIMUM RATINGS

ITEM	SYMBOL	MIN.	MAX.	UNIT	REMARK
Power Supply Voltage	VDD	-0.3	4	V	
Backlight Supply Voltage	VLED	-	18	V	

Note : The absolute maximum rating values of this product not allowed to be Exceeded at any times. Should be module be used with any of absolute maximum ratings exceeded. The characteristics of the module may not be recovered, or in an extreme case, the module may be permanently destroyed.

6.2 ENVIRONMENTAL ABSOLUTE MAXIMUM RATINGS

ITEM	OPERATING		STORAGE		REMARK
	MIN.	MAX.	MIN.	MAX.	
Ambient Temperature(°C)	-20	70	-30	80	Note 1,2
Humidity(% RH)	10~90		10~90		-

Note 1 : The response time will become lower when operated at low temperature.

Note 2 : Background color changes slightly depending on ambient temperature.



7. ELECTRICAL CHARACTERISTICS

7.1 ELECTRICAL CHARACTERISTICS OF LCD

Ta=25°C

ITEM	SYMBOL	MIN.	TYP.	MAX.	UNIT	REMARK
Power Voltage For LCD	VDD	3.0	3.3	3.6	V	
	IDD	-	(300)	-	mA	Note1
Differential Input Threshold	VTH	-	-	+100	mV	Note2
	VTL	-100	-	-	mV	
Magnitude Differential Input	VID	100		600	mV	
Common Mode Voltage	V _{CM}	0.7	-	1.6	V	

Note 1 : Test Condition: VDD=3.3V ; Test Pattern: White.

Note 2 : VTH and VTL is defined in RxIN0+/- 、 RxIN1+/- 、 RxIN2+/- 、 RxIN3+/- 、 CLKIN+/- signal voltage level.

Single-end signals

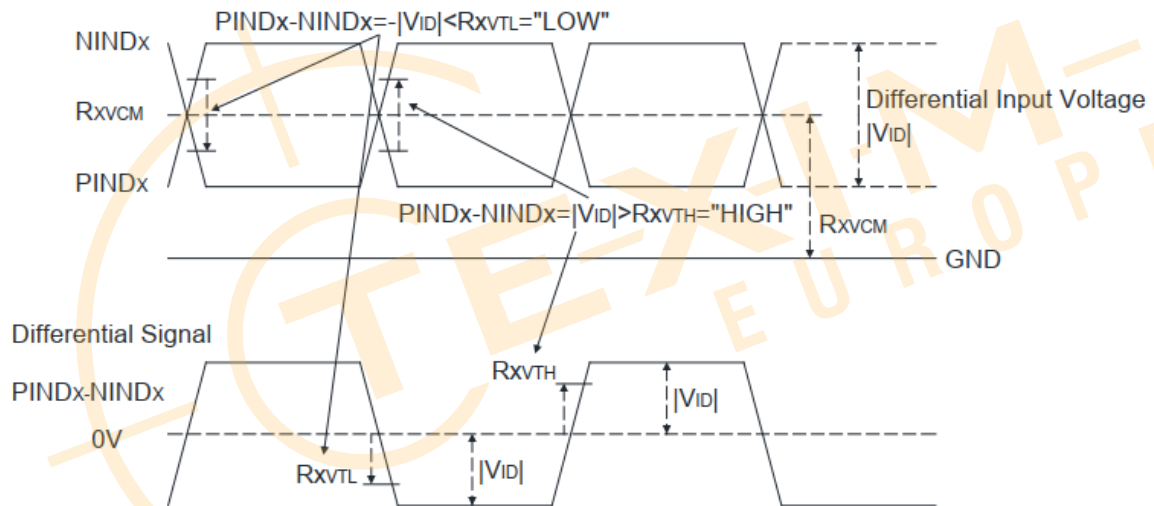

7.2 BACKLIGHT UNITS

Ta=25°C

ITEM	SYMBOL	MIN.	TYP.	MAX.	UNIT	REMARK
Forward Voltage	VLED	11.5	12	12.5	V	
Forward Current	ILED	-	450	-	mA	VLED=12V
Brightness Control	High	1.2	-	-	V	
	Low	0	-	0.4	V	
PWM Frequency	-	200		1000	Hz	
LED Life Time	Lf	30,000	50,000	-	Hrs	

Note 1 : The lifetime of LED is defined as the time when it continues to operate under the conditions at Ta= 25 ±2°C and PWM = 100% (LED forward current) until the brightness becomes ≤50% of its original value.
50,000 is only an estimate for reference.

7.3 CTP ELECTRICAL CHARACTERISTICS

ITEM	SYMBOL	MIN.	TYP.	MAX.	UNIT	REMARK
Power Voltage For PCAP	VCC	/	5.0	/	V	

8. OPTICAL CHARACTERISTICS

8.1 Optical specification

Ta=25°C

ITEM	SYMBOL	CONDITIONS	MIN.	TYP.	MAX.	UNIT	REMARK
Contrast Ratio	CR	Viewing Normal Angle $\Theta_x=\Theta_y=0^\circ$	600	800	-	-	Note 1
Response Time	Tr+Tf		-	25	50	ms	Note 2
Color Chromaticity	White	Wx	0.26	0.31	0.36		Note 4
		Wy	0.27	0.32	0.37		
Viewing Angle	Hor.	θ_L	75	85	-	Deg.	Note 4
		θ_R	75	85	-		
	Ver.	θ_U	75	85	-		
		θ_D	75	85	-		
Luminance(Center)	L	PWM=100%	800	900	-	cd/m ²	Center
Luminance Uniformity	YU		70	75	-	%	Note 5

Note 1 : Definition of Contrast Ratio (CR) :

The contrast ratio can be calculated by the following expression.

$$\text{Contrast Ratio (CR)} = L_{63}/L_0$$

L63 : Luminance of gray level 63

L0 : Luminance of gray level 0

$$\text{CR} = \text{CR}(5)$$

CR(X) is corresponding to the Contrast Ratio of the point X at Figure in Note 5

Note 2 : Definition of Response Time (TR.TF)

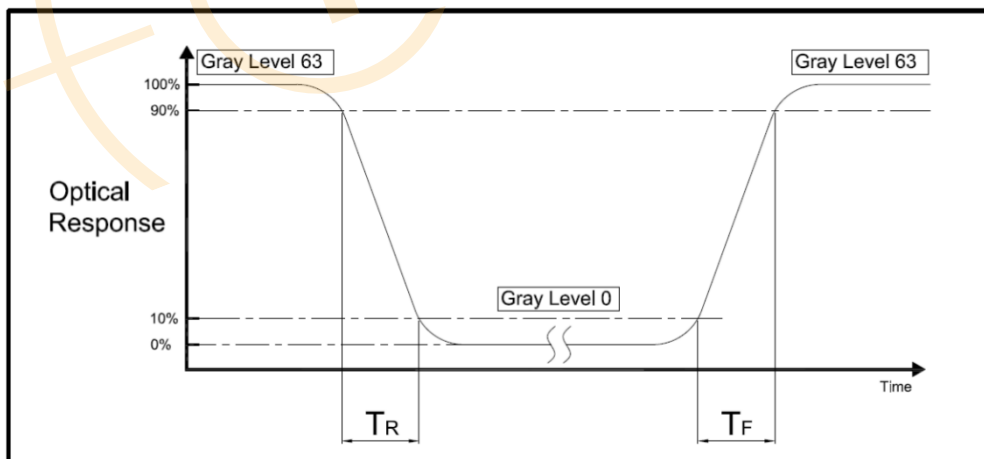

Note 3 : Definition of Viewing Angle

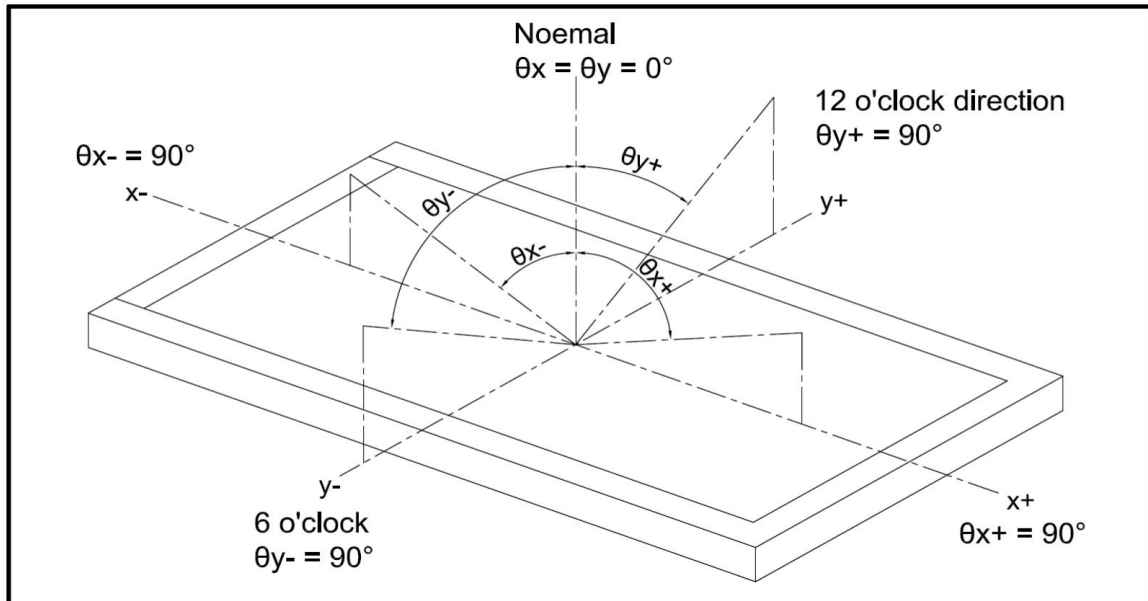

Note 4 : Measurement Set-Up:

The LCD module should be stabilized at a given temperature for 20 minutes to avoid abrupt temperature change during measuring. In order stabilize the luminance, the measurement should be executed after lighting Backlight for 20 minutes in a windless room.

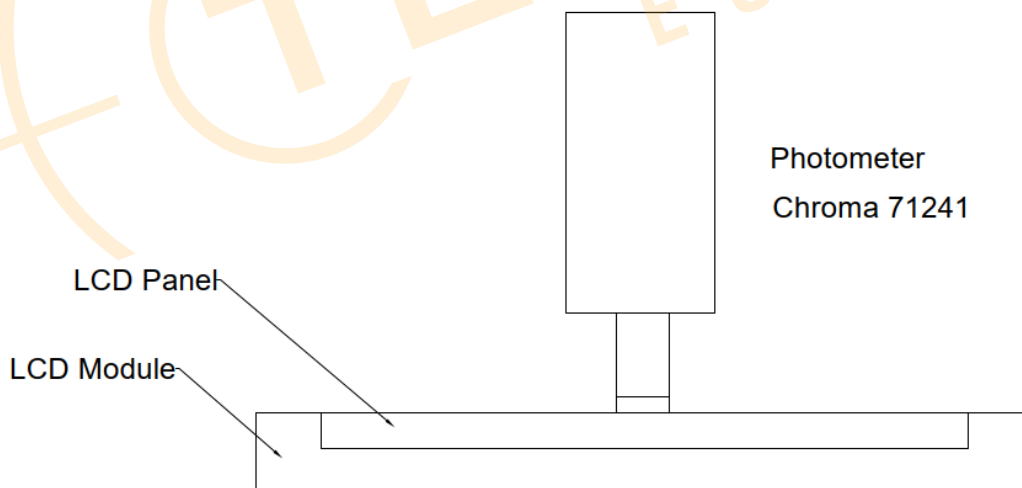

Note 5: Definition of uniformity

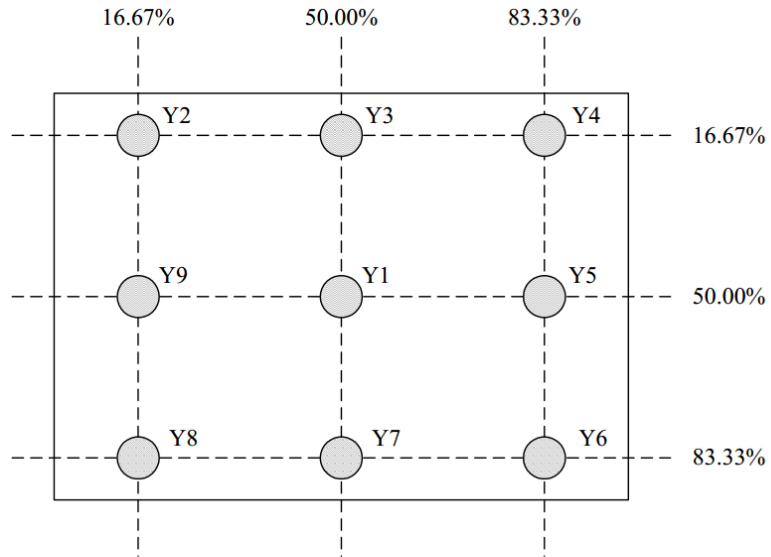

$$\text{Luminance uniformity} = \frac{(\text{Min Luminance of 9 points})}{(\text{Max Luminance of 9 points})} \times 100\%$$

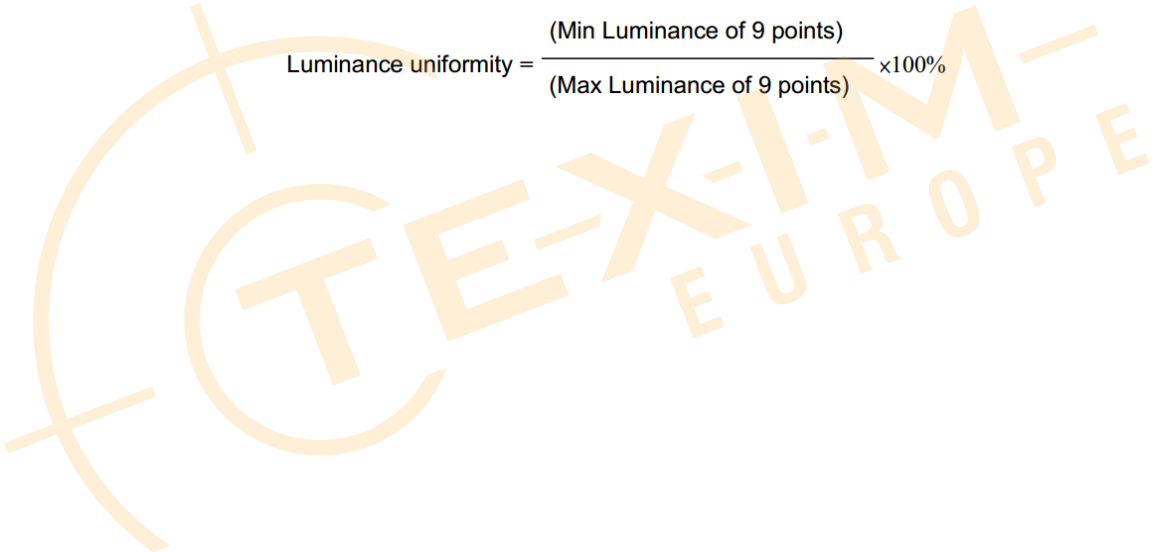

9. TOUCH PANEL SPECIFICATIONS

9.1 Type :

9.2 STRUCTURE :

9.2.1 Thickness : 2.0±0.2mm

9.2.1 Thickness : 2.0mm (Cover 1.1t / Sensor 0.7t / COF 0.2)

9.3 IC MODEL :

9.3.1 IC manufacture : EETI

9.3.2 IC part number : EXC81W46

9.3.3 Interface : USB

9.4 ELECTRICAL CHARACTERISTICS :

9.4.1 Operating Voltage : +5V

9.5 MECHANICAL CHARACTERISTICS :

9.5.1 Surface hardness : 6H

9.6 OPTICAL CHARACTERISTICS :

9.6.1 Transparency : $\geq 85\%$

9.6.2 Haze:TBD



10. TIMING SPECIFICATIONS

10.1 Power on/off Sequence

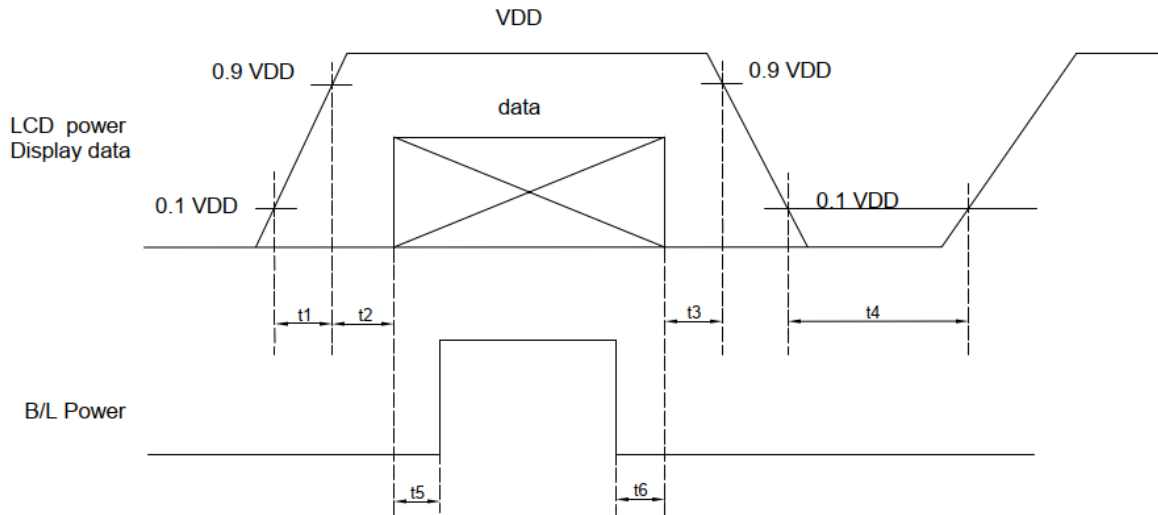

ITEM	MIN.	MAX.	NOTE
t1	0.5	10	
t2	0	50	
t3	0	50	
t4	200	-	
t5	200	-	
t6	0	-	

UNIT: ms

10.2 Timing Table

ITEM	SYMBOL	MIN.	TYP.	MAX.	UNIT	NOTE
DCLK frequency	1/Tc	66.3	72.4	78.9	MHz	Frame rate=60Hz
Horizontal Display area	tHD	1280			Tc	
HSYNC pulse width	tHPW	2	-	40	Tc	
HSYNC back porch(with pulse width)	tHBP	88	88	88	Tc	
HSYNC front porch	tHFP	12	72	132	Tc	
Vertical display area	tVD	800			tH	
VSYNC pulse width	tVPW	2	-	20	tH	
VSYNC back porch(with pulse width)	tVBP	23	23	23	tH	
VSYNC front porch	tVFP	1	15	49	tH	

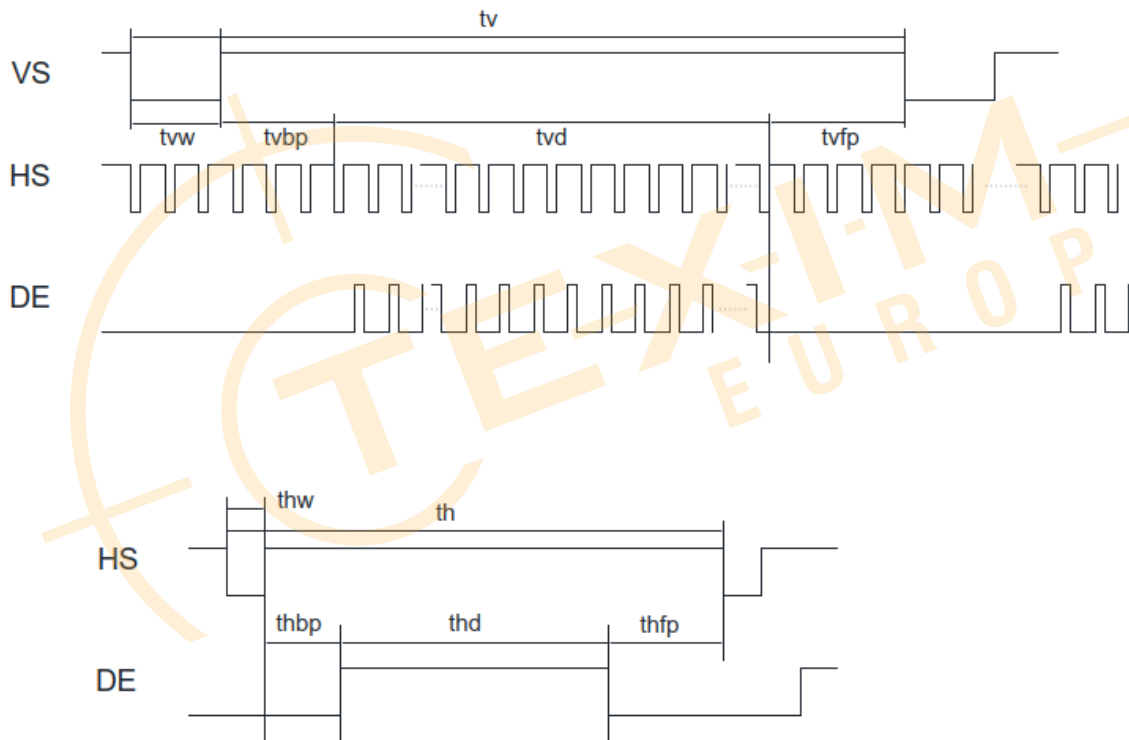

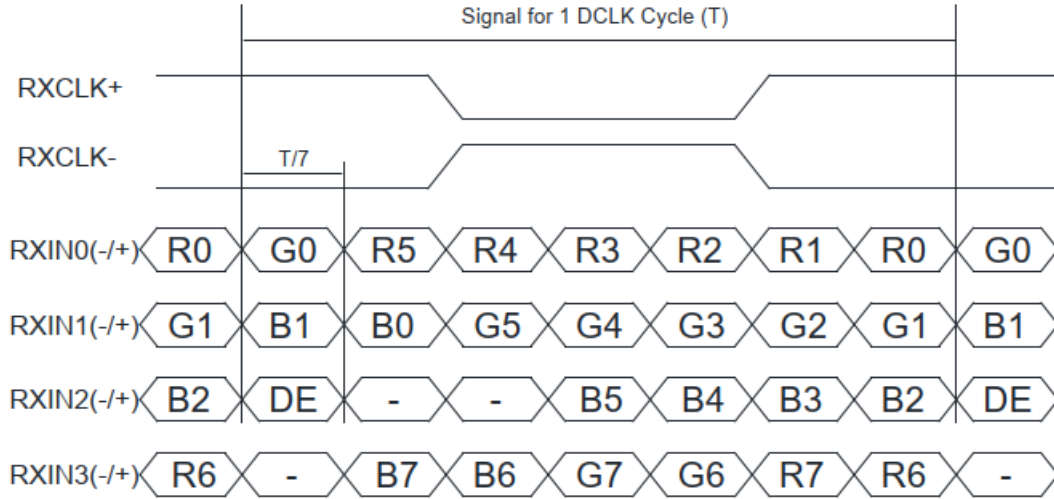
10.3 Data Input Format

11. RELIABILITY TEST

ENVIRONMENTAL TEST				
NO.	ITEM	CONDITIONS	TIME PERIOD	REMARK
1	High Temperature Storage	Ta= 80°C	240Hours	1,2,3,4
2	Low Temperature Storage	Ta= -30°C	240Hours	1,2,3,4
3	High Temperature Humidity Storage	40°C,90%RH	240Hours	1,2,3,4
4	High Temperature Operation	Ts= 70°C	240Hours	1,2,3,4
5	Low Temperature Operation	Ta= -20°C	240Hours	1,2,3,4,5
6	Temperature Cycle	-20°C~70°C (30min) (30min)	100 CYCLES	1,2,3

In the standard condition, there shall be no practical problem that may affect the display function. After the reliability test, the product only guarantees operation, but don't guarantee all of the cosmetic specification.

Note 1 : Ta is the ambient temperature of samples.

Note 2 : Ts is the temperature of panel's surface.

Note 3 : Before cosmetic and function test, the product must have enough recovery time, at least 2 hours at room temperature.

Note 4 : Start with cold temperature and end with high temperature.

12. PRECAUTIONS FOR USE

12.1 SAFETY

- (1) Do not swallow any liquid crystal, even if there is no proof that liquid crystal is poisonous.
- (2) If the LCD panel breaks, be careful not to get liquid crystal to touch your skin.
- (3) If skin is exposed to liquid crystal, wash the area thoroughly with alcohol or soap.

12.2 STORAGE CONDITIONS

- (1) Store the panel or module in a dark place where the temperature is $23\pm 5^{\circ}\text{C}$ and the humidity is below $50\pm 20\%\text{RH}$.
- (2) Store in anti-static electricity container.
- (3) Store in clean environment, free from dust, active gas, and solvent.
- (4) Do not place the module near organics solvents or corrosive gases.
- (5) Do not crush, shake, or jolt the module.

12.3 HANDLING PRECAUTIONS

- (1) Avoid static electricity which can damage the CMOS LSI.
- (2) The polarizing plate of the display is very fragile. So, please handle it very carefully.
- (3) Do not give external shock.
- (4) Do not apply excessive force on the surface.
- (5) Do not wipe the polarizing plate with a dry cloth, as it may easily scratch the Surface of plate.
- (6) Do not use ketonic solvent & Aromatic solvent, use with a soft cloth soaked with a cleaning naphtha solvent.
- (7) Do not operate it above the absolute maximum rating.
- (8) Do not remove the panel or frame from the module.
- (9) When the module is assembled, it should be attached to the system firmly, Be careful not to twist and bend the module.
- (10) Wipe off water droplets or oil immediately . If you leave the droplets for a long time, staining and discoloration may occur.
- (11) If the liquid crystal material leaks from the panel, it should be kept away from the eyes or mouth. In case of contact with hands, legs or clothes, it must be washed away thoroughly with soap.

12.4 WARRANTY

- (1) Acceptance inspection period. The period is within one month after the arrival of contracted commodity at the buyer's factory site.
- (2) Applicable warrant period. The period is within 12 months since the date of shipping out under normal using and storage conditions.

Disclaimer

ALL PRODUCTS, PRODUCT SPECIFICATIONS AND DATA ARE SUBJECT TO CHANGE WITHOUT NOTICE TO IMPROVE RELIABILITY, FUNCTION OR DESIGN OR OTHERWISE.

Texim Europe B.V. its affiliates, agents, and employees, and all persons acting on its or their behalf (collectively, "Texim"), disclaim any and all liability for any errors, inaccuracies or incompleteness contained in any datasheet or in any other disclosure relating to any product.

Texim makes no warranty, representation or guarantee regarding the suitability of the products for any particular purpose or the continuing production of any product.

It is the customer's responsibility to validate that a particular product with the properties described in the product specification is suitable for use in a particular application.

Parameters provided in datasheets and / or specifications may vary in different applications and performance may vary over time.

All operating parameters, including typical parameters, must be validated for each customer application by the customer's technical experts.

Please contact us if you have any questions about the contents of the datasheet.

This may not be the latest version of the datasheet. Please check with us if a later version is available.

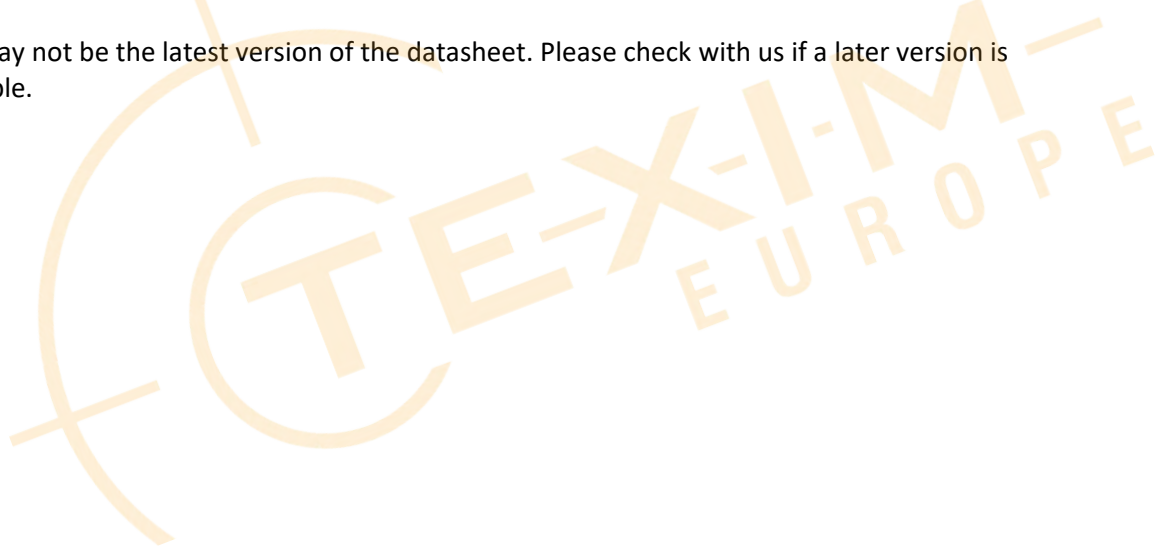



Headquarters & Warehouse

Elektrostraat 17
 NL-7483 PG Haaksbergen
 The Netherlands

T: +31 (0)53 573 33 33
 E: info@texim-europe.com
 Homepage: www.texim-europe.com



The Netherlands

Elektrostraat 17
 NL-7483 PG Haaksbergen

T: +31 (0)53 573 33 33
 E: nl@texim-europe.com



Belgium

Zuiderlaan 14, box 10
 B-1731 Zellik

T: +32 (0)2 462 01 00
 E: belgium@texim-europe.com



UK & Ireland

St Mary's House, Church Lane
 Carlton Le Moorland
 Lincoln LN5 9HS

T: +44 (0)1522 789 555
 E: uk@texim-europe.com



Germany

Bahnhofstrasse 92
 D-25451 Quickborn

T: +49 (0)4106 627 07-0
 E: germany@texim-europe.com



Germany

Martin-Kollar-Strasse 9
 D-81829 München

T: +49 (0)89 436 086-0
 E: muenchen@texim-europe.com



Austria

Martin-Kollar-Strasse 9
 D-81829 München

T: +49 (0)89 436 086-0
 E: austria@texim-europe.com



Nordic

Stockholmsgade 45
 2100 Copenhagen

T: +45 88 20 26 30
 E: nordic@texim-europe.com



Italy

Martin-Kollar-Strasse 9
 D-81829 München

T: +49 (0)89 436 086-0
 E: italy@texim-europe.com