

SPECIFICATION FOR CTP+LCD MODULE

Part No.: TF150TM013-V1

Customer No.:

Date: 2026-4-21

Supplier			Customer
Prepared	Checked	Approved	Approved

Record of Revision

Rev.	Description	Page	Date
0	Preliminary specification released	/	20260421



Table of Contents

1 General Specifications	4
2 Mechanical Drawing	5
3 Pin assignment	6
4 Absolute Maximum Rating	9
5 LCD Electrical Characteristic	10
6 Optical Characteristics	15
7 Reliability Test	18
8 Appearance Inspection	19
9 Notices	22



1 General Specifications

1.1 Definition

The specification is used for capacitive touch module with TFT LCD & Backlight Unit.

1.2 Features and General Description

General	Specification	Unit	Note
Module Size	15	inch	diagonal
Structure	G+G+LCD, OCR Bonding		
Resolution	1024(RGB) × 768		
Display Mode	Normally Black. Transmissive		
Pixel Pitch	0.297(W) × 0.297(H)	mm	
Pixel Arrangement	RGB Vertical stripe		
Viewing Direction	ALL	O'clock	
Outline Dimensions	345.13(W) × 269.1(H) × 16.8(D)	mm	
Viewing Area	305.13(W) × 228.1(H)		
Active Area	304.128(W) × 228.096(H)	mm	
LCD Interface	LVDS		
CTP Interface	USB / I2C / RS232		
CTP IC	EXC81H84		
Touch Point	10		
Surface Hardness	6	H	
Surface Treatment	Etched AG(Gloss: 80±15)		

2 Mechanical Drawing

RoHS

A

1	△	POG Sharing TF150T009-V1
VER.	SYMBOL	AMENDMENT
4		

B

General Specification:

1. Structure: (GAD)+LCD, OGR bending
2. CCT: cold=11m, glass class, normally tempered
3. Transmittance: Normally Black, 1024*(RGB)*768
4. Surface hardness: ≥8H
5. LCD interface: LVDS
6. CTP IC: EXC8184, TX2740X36, COB
7. CTP interface: ISB/12C/RS232
8. Operating Temp.: -30 to 80°C
9. Storage Temp.: -30 to 80°C
10. Luminance(W/CTP): 1000cd/m² (Min.), 1250cd/m² (Typ.)
11. General Tolerance: ±0.5

C

D

Front view

Side view

Back view

E

DRW/N	Zhu
CHECKED	Jun
APPROVED	
Customer No:	

DATE	20280421
SHEET	1 OF 1

A

CTP+LCD	Drawing NO:
Product NO:	TF150T003-V1

B

C

D

E

5

Distributed by www.texim-europe.com

3 Pin assignment

3.1 LCD Pin assignment

LVDS connector: MSB240420-HE (STM)

Pin	Symbol	Description	Note
1	LCD_VDD	Power Supply, 3.3V(typ.)	
2	LCD_VDD	Power Supply, 3.3V(typ.)	
3	VSS	Ground	
4	NC	No connection	
5	RIN0-	-LVDS differential data input 0	
6	RIN0+	+LVDS differential data input 0	
7	VSS	Ground	
8	RIN1-	-LVDS differential data input 0	
9	RIN1+	+LVDS differential data input 0	
10	VSS	Ground	
11	RIN2-	-LVDS differential data input 0	
12	RIN2+	+LVDS differential data input 0	
13	VSS	Ground	
14	CLKIN-	-LVDS differential clock input CLK	
15	CLKIN+	+LVDS differential clock input CLK	
16	VSS	Ground	
17	RIN3-	-LVDS differential data input 0	
18	RIN3+	+LVDS differential data input 0	
19	VSS	Ground	
20	NC	No connection	

LED connector: 12507WR-H10L (YEONHO)

Pin	Symbol	Description
1	VIN(12V)	Power Supply (10.8V~13.2V)
2	VIN(12V)	Power Supply (10.8V~13.2V)
3	VIN(12V)	Power Supply (10.8V~13.2V)
4	NC	No connection
5	GND	Ground
6	GND	Ground
7	GND	Ground
8	VBLON	LED-EN $V_{IH}>2V$, $V_{IL}<0.8V$, high active
9	VPWM	PWM, 200Hz~2kHz, 5%~100%, $V_{IH}>2V$, $V_{IL}<0.8V$
10	NC	No connection



3.2 CTP Pin assignment

USB connector: JP1

Pin	Symbol	Description
1	GND_E	Ground
2	VDD	CTP Power Supply : 5V
3	GND	Ground
4	D+	CTP USB data port plus
5	D-	CTP USB data port minus

I2C connector: JP5

Pin	Symbol	Description
1	GND	Ground
2	I2C_SDA	CTP I2C SDA signal
3	I2C_SCL	CTP I2C SCL signal
4	VDD	CTP Power Supply : 5V
5	I2C_INT	CTP I2C INT signal

RS232 connector: JP5

Pin	Symbol	Description
1	UR_CTS	CTP RS232 CTS signal
2	UR_TX	CTP RS232 TX signal
3	UR_RX	CTP RS232 RX signal
4	UR_RTS	CTP RS232 RTS signal
5	GND_E	Ground
6	VDD	CTP Power Supply : 5V
7	GND	Ground

4 Absolute Maximum Rating

The followings are maximum values which, if exceed, may cause faulty operation or damage to the unit. The operational and non-operational maximum voltage and current values are listed in Table

Parameter	Symbol	Min.	Max.	Unit	Remark
Power Supply Voltage	VDD	VSS-0.3	3.6	V	Ta = 25 °C
	VBLU	VSS-0.3	13.2	V	Ta = 25 °C
Operating Temperature	T _{OP}	-30	+80	°C	Note 1
Storage Temperature	T _{ST}	-30	+80	°C	
Operating Ambient Humidity	Hop	10	90	%RH	
Storage Humidity	Hst	10	90	%RH	

Note 1 : Temperature and relative humidity range are shown in the figure below.

Wet bulb temperature should be 39 °C max. and no condensation of water.

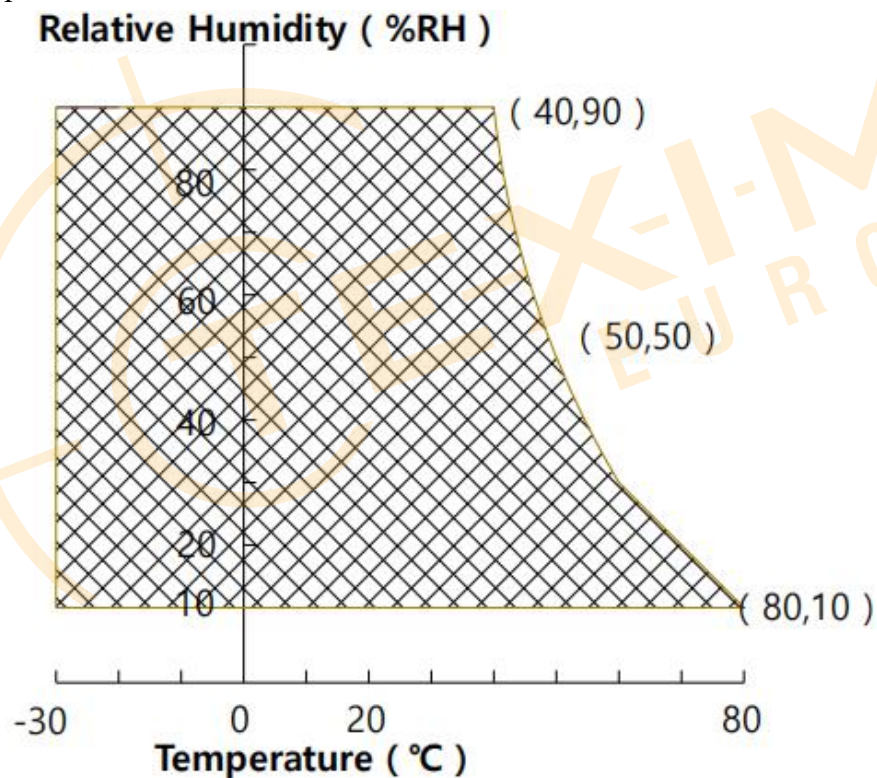

5 LCD Electrical Characteristic

5.1 TFT LCD Module

Parameter		Symbol	Values			Unit	Remark
			Min	Typ	Max		
Power Supply Input Voltage		VDD	3.0	3.3	3.6	V	Note 1
Power Supply Current		IDD	-	455	900	mA	
Power Supply Ripple Voltage		VRP	-	-	300	mV	
Rush Current		IRUSH	-	2	3	A	Note 2
LVDS Interface	Differential Input High Threshold Voltage	VLVTH	-	-	+100	mV	VLVC=1.2V
	Differential Input Low Threshold Voltage	VLVTL	-100	-	-	mV	
	Common Input Voltage	VLVC	-	1.2V	VCC_LVDS-0.4- VID /2	V	
CMOS Interface	Input High Threshold Voltage	VIH	0.6VDD	-	VDD	V	
	Input Low Threshold Voltage	VIL	0	-	0.3VDD	V	
Power Consumption		PD		1.5	3	W	
		PBL		24.5	26		Note 3
		Ptotal		26	29		

Note 1 : The supply voltage is measured and specified at the interface connector of LCM.

The current draw and power consumption specified is for VDD=3.3V,

Frame rate fV=60Hz and Clock frequency = 65MHz.

Test Pattern of power supply current

a) Typ : Mosaic 7X5 (L0/L255) b) Max : Vline Subline (L255)

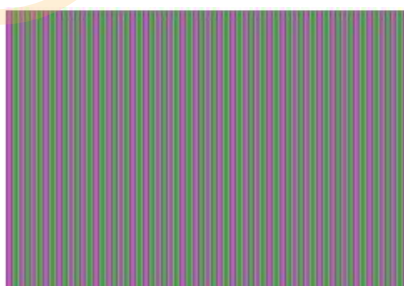
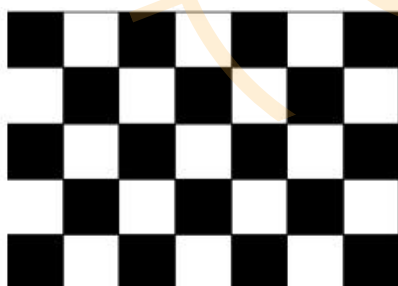

5.2 Backlight Unit

Parameter		Min.	Typ.	Max.	Unit	Remarks	
LED Driver Power Supply Voltage		VLED	10.8	12	12.6	V	
LED Driver Power Supply Current		ILED	-	2000	21600	mA	
EN Control Level	Backlight on	V _{ENH}	3	-	5	V	EN logic high voltage
	Backlight off	V _{ENL}	0	0	0.8	V	EN logic low voltage
PWM Control Level	PWM High Level	V _{PML}	3	3.3	5	V	
	PWM Low Level	V _{PML}	0	0	0.8	V	
PWM Control Frequency		F _{PWM}	0.2	-	2	KHz	Refer to customer comments
Duty Ratio		-	5	-	100	%	
LED Life-Time		N/A	50,000	-	-	Hour	Note1
BLU Power Consumption		PBL	-	24.5	26	W	Note2

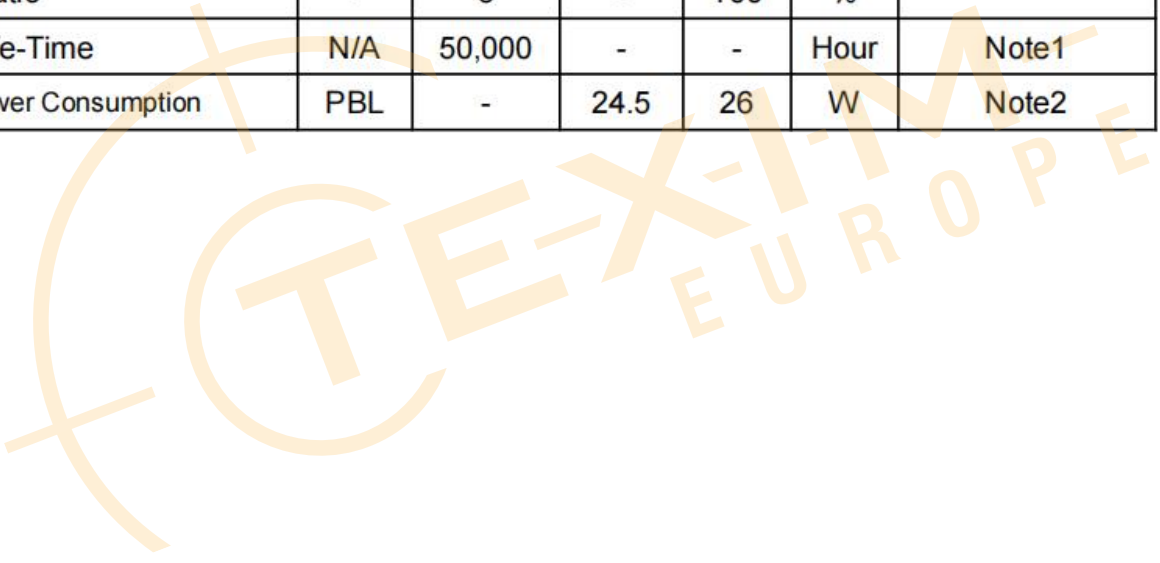

5.3 SIGNAL TIMING SPECIFICATION

5.3.1 Timing Parameters (DE only mode)

Item		Symbols	Min	Typ	Max	Unit	
Clock	Frequency	1/Tc	52	65	71	MHz	
	High Time	Tch	-	4/7Tc	-		
	Low Time	Tcl	-	3/7Tc	-		
Frame Period		Tv	48	60	63	Hz	
Horizontal Active Display Term		Valid	t _{HV}	-	1024	-	t _{CLK}
		Total	t _{HP}	1200	1344	1400	t _{CLK}
Vertical Active Display Term		Valid	t _{VV}	-	768	-	t _{HP}
		Total	t _{VP}	788	806	845	t _{HP}

Note

1. DE Only Mode, While operation, DE signal should be have the same cycle. The input of HSYNC & VSYNC signal does not have an effect on normal operation.
2. Best operation clock frequency is 65 Mhz.
3. Frequency = [H Total] * [V Total] * [vertical Frame rate]
H Total, V Total and Frame rate should operate within the range between Frequency_Min and Max
4. Main frequency Max is 71 Mhz MHz without spread spectrum

Symbol	Parameter	Condition	Min	Typ	Max	Unit
F _{LVMOD}	Modulating frequency of input clock during SSC	-	-	-	100	KHz
F _{LVDEV}	Maximum deviation of input clock frequency during SSC		-3	-	+3	%

5.3.2 Signal Timing Waveform

Horizontal Timing Waveform

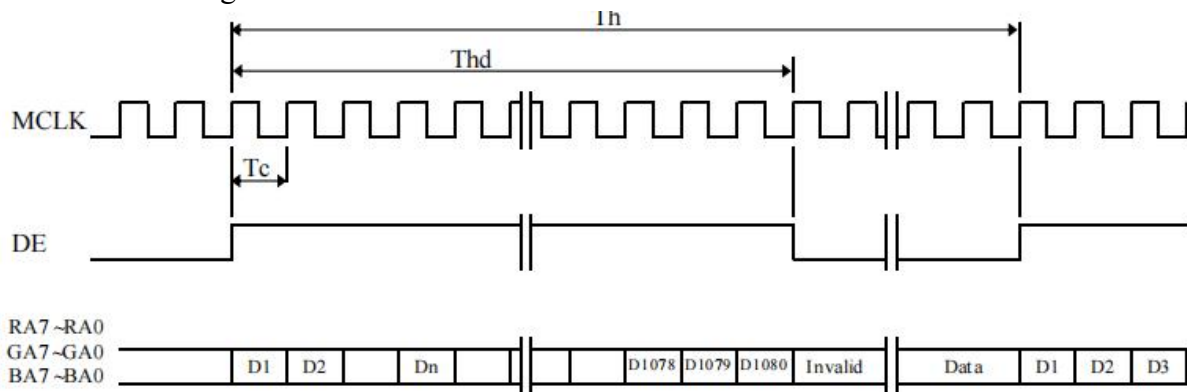

Vertical Timing Waveform

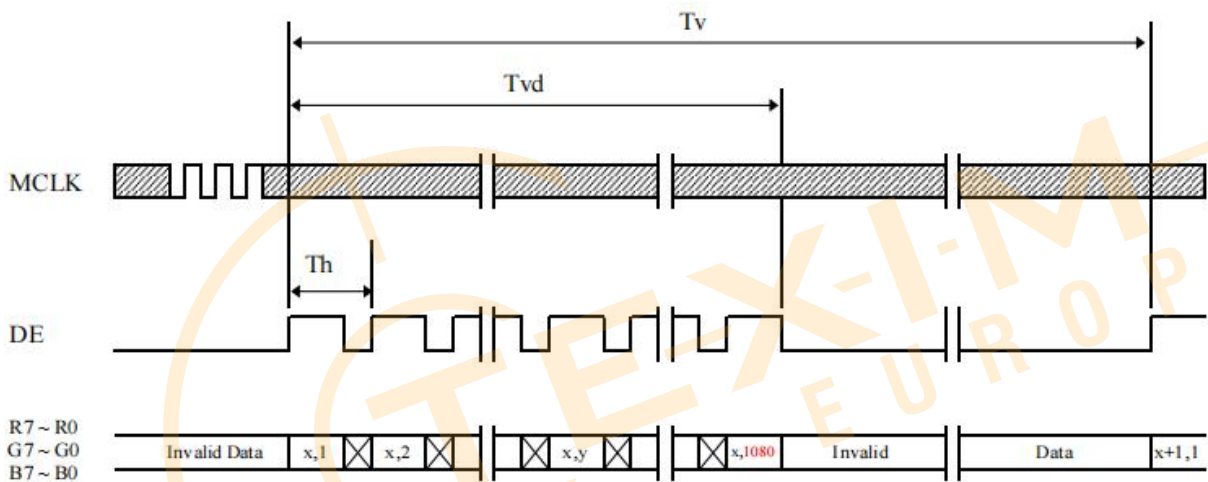

5.3.3 Timing Parameters (DE only mode)

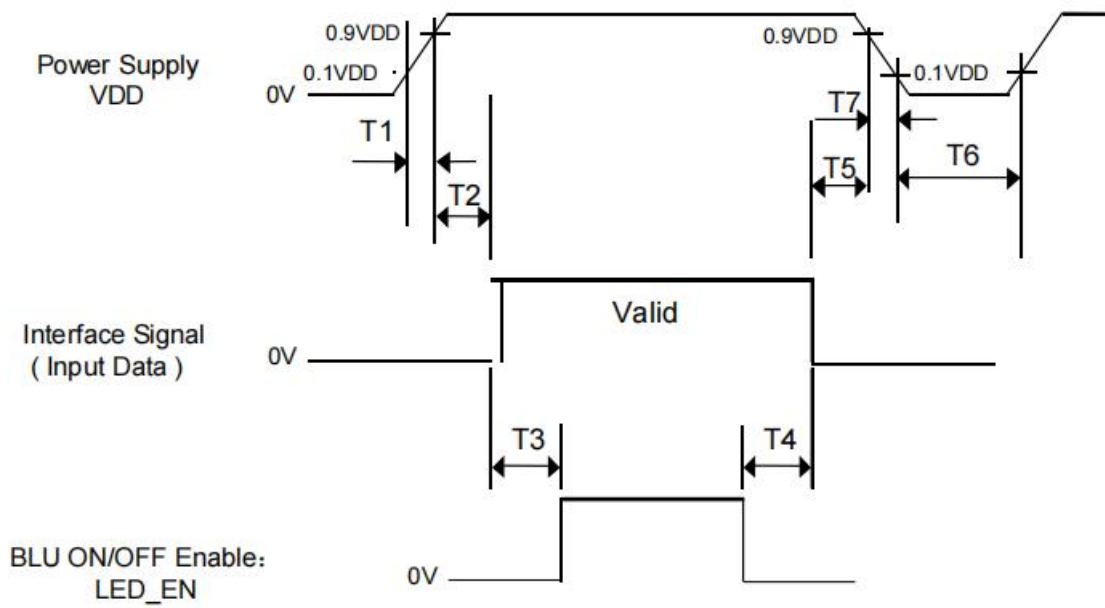

Parameter	Values			Units
	Min	Typ	Max	
T1	0.5	-	10	ms
T2	0	-	50	ms
T3	500	-	-	ms
T4	500	-	-	ms
T5	0	-	30	ms
T6	1	-	-	s

- Notes:
1. Back Light must be turn on after power for logic and interface signal are valid.
 2. Even though T1 is out of SPEC, it is still ok if the inrush current of VDD is below the limit.
 3. When $VDD < 0.9VDD(Typ.)$, Power off.
 4. T7 decreases smoothly, if there were rebounding voltage, it must smaller than 0.5 volts.

6 Optical Characteristics

Item		Symbol	Condition	Min.	Typ.	Max.	Unit	Note
Viewing Angle	Horizontal	θ_{X+}	$CR \geq 10$	85	89	-	Deg.	(1), (5)
		θ_{X-}		85	89	-	Deg.	
	Vertical	θ_{Y+}		85	89	-	Deg.	
		θ_{Y-}		85	89	-	Deg.	
Luminance (W/ CTP)		Lv	$\theta_X=0^\circ, \theta_Y=0^\circ$	1000	1250	-	nit	(4), (5)
Uniformity	9 points	$\Delta Y9$		75	80	-	%	(5), (6)
Contrast ratio		CR		700	1000	-		(2), (5)
Color Chromaticity (CIE 1931)	White	W_x	$\theta_X=0^\circ, \theta_Y=0^\circ$ R=G=B=255 Gray scale	Typ- 0.05	0.313	Typ+ 0.05	-	(1), (5)
		W_y			0.329		-	
	Red	R_x			-		-	
		R_y			-		-	
	Green	G_x			-		-	
		G_y			-		-	
	Blue	B_x			-		-	
		B_y			-		-	
Response Time	T_R+T_F		-	14	25	ms	(3)	

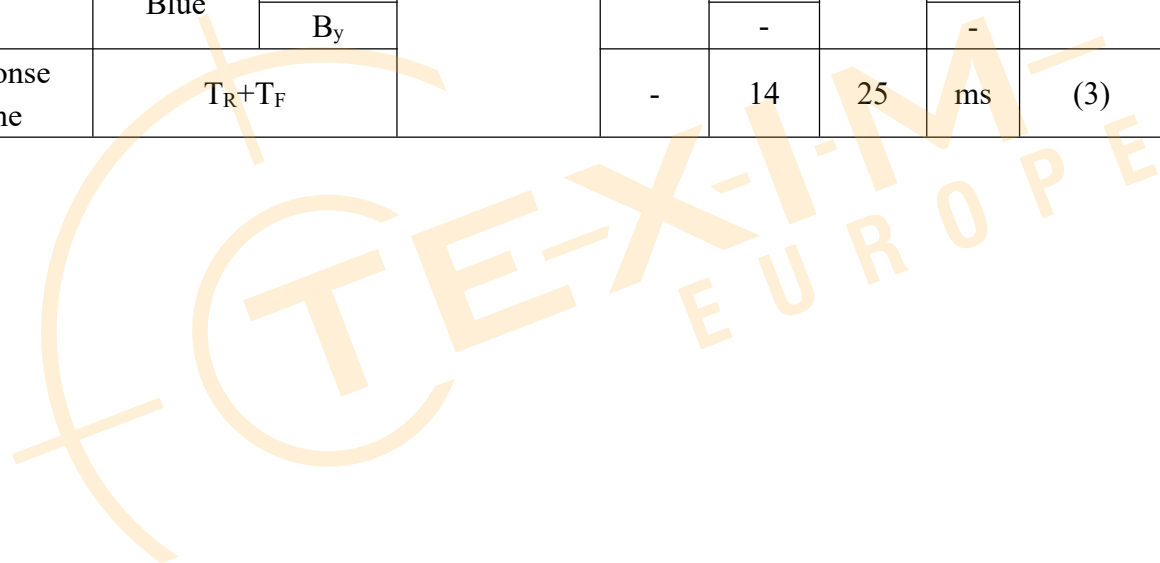

Note (1) Definition of Viewing Angle (θ_x, θ_y):

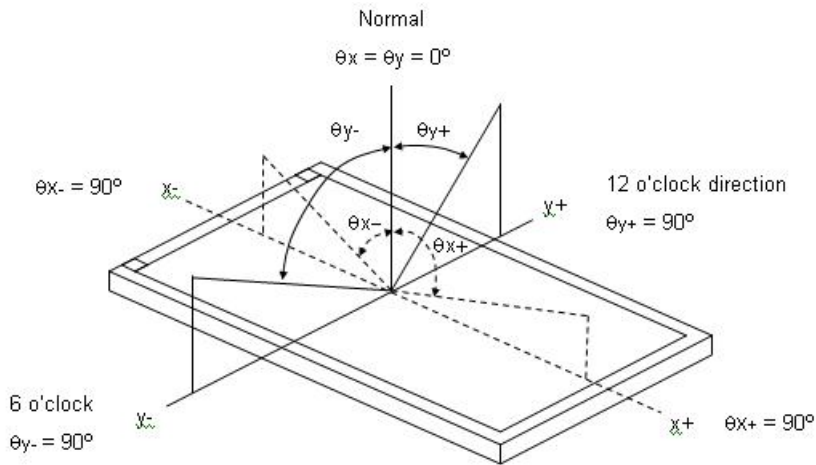

Note (2) Definition of Contrast Ratio (CR):

The contrast ratio can be calculated by the following expression.

$$\text{Contrast Ratio (CR)} = L_{255} / L_0$$

L255: Luminance of gray level 255

L 0: Luminance of gray level 0

$$\text{CR} = \text{CR} (5)$$

CR (X) is corresponding to the Contrast Ratio of the point X at Figure in Note (6).

Note (3) Definition of Response Time (T_R, T_F):

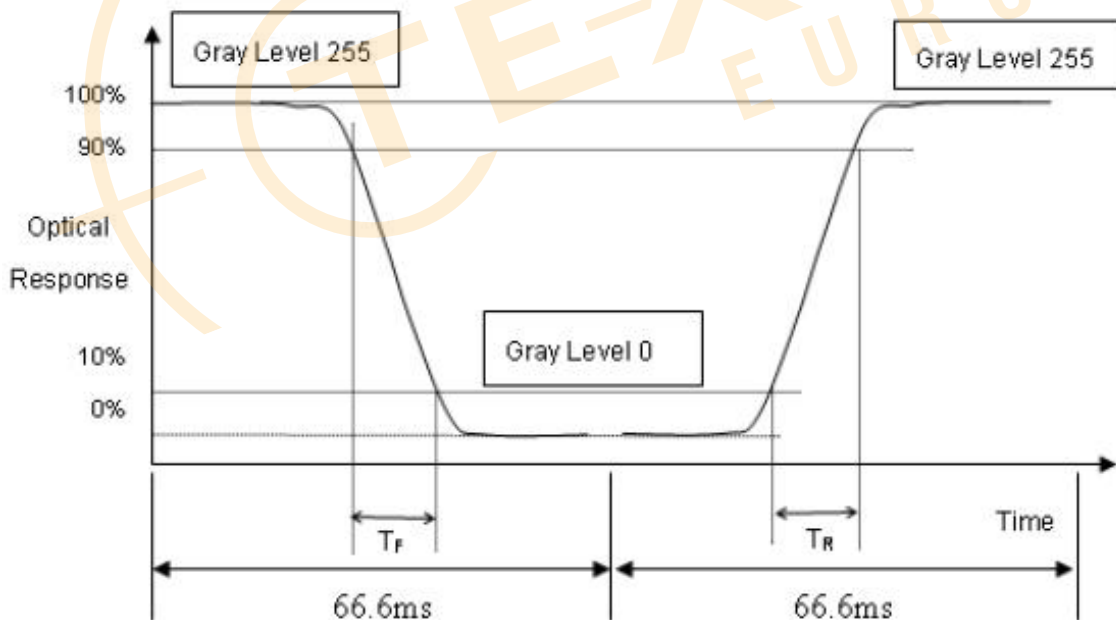

Note (4) Definition of Luminance of White (LC):

Measure the luminance of gray level 255 at center point

$$LC = L (5)$$

L (x) is corresponding to the luminance of the point X at Figure in Note (6).

Note (5) Measurement Setup:

The LCD module should be stabilized at given temperature for 30 minutes to avoid abrupt temperature change during measuring. In order to stabilize the luminance, the measurement should be executed after lighting Backlight for 30 minutes in a windless room.

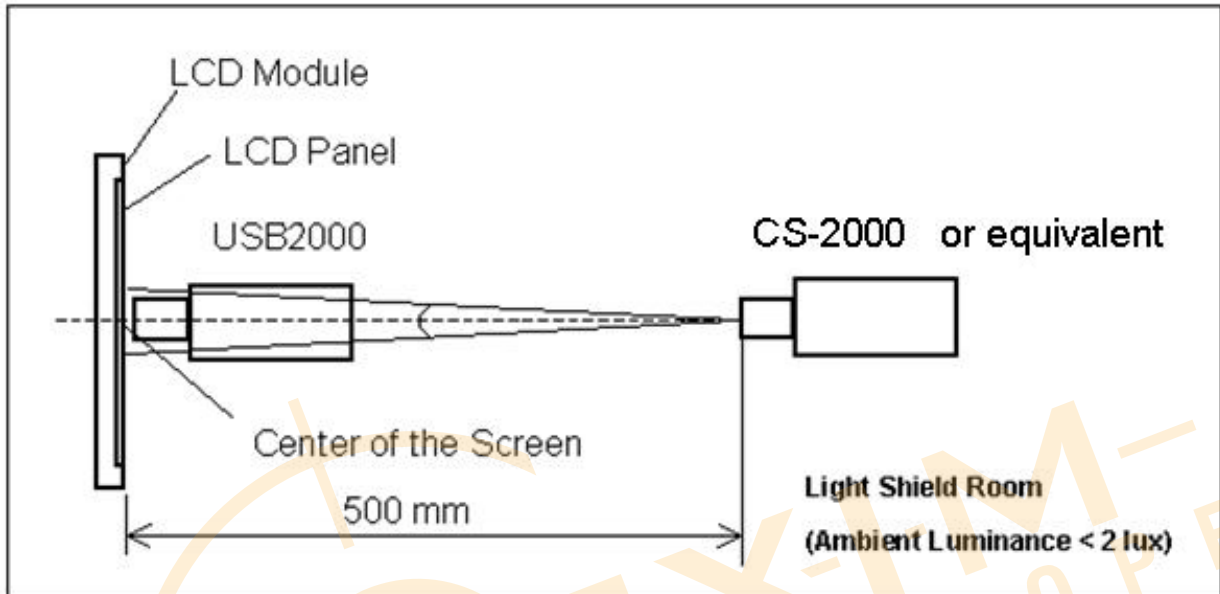

Note (6) Definition of White Variation (δW):

Measure the luminance of gray level 255 at 9 points

$$\delta W = (\text{Minimum} [L (1) \sim L (9)] / \text{Maximum} [L (1) \sim L (9)]) * 100\%$$

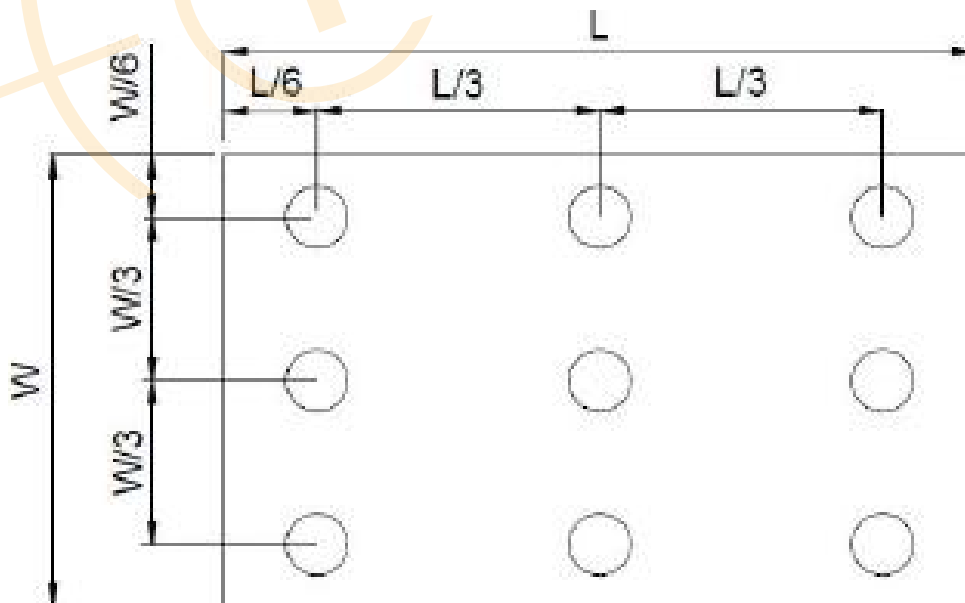

7 Reliability Test

Test Item	Condition
High Temperature Storage Test	80°C, 240 hrs
Low Temperature Storage Test	-30°C, 240 hrs
High Temperature Operation Test	80°C, 240 hrs
Low Temperature Operation Test	-30°C, 240 hrs
High temperature & high humidity operation Test	60°C, 90%RH, 240 hrs
Thermal Shock Test (TST)	-20°C/30min, 60°C/30min, 100 cycles
Electro-static discharge test (non-operating)	Air : 150 pF, 330Ω, 15 KV Contact : 150 pF, 330Ω, 8 KV

Note :

- (1) There should be no condensation on the surface of panel during test.
- (2) At testing Vibration and Shock, the fixture in holding the module has to be hard and rigid enough so that the module would not be twisted or bent by the fixture.
- (3) In the standard conditions, there is no function failure issue occurred. All the cosmetic specification is judged before reliability test.
- (4) Before cosmetic and function test, the product must have enough recovery time, at least 24 hours at room temperature.

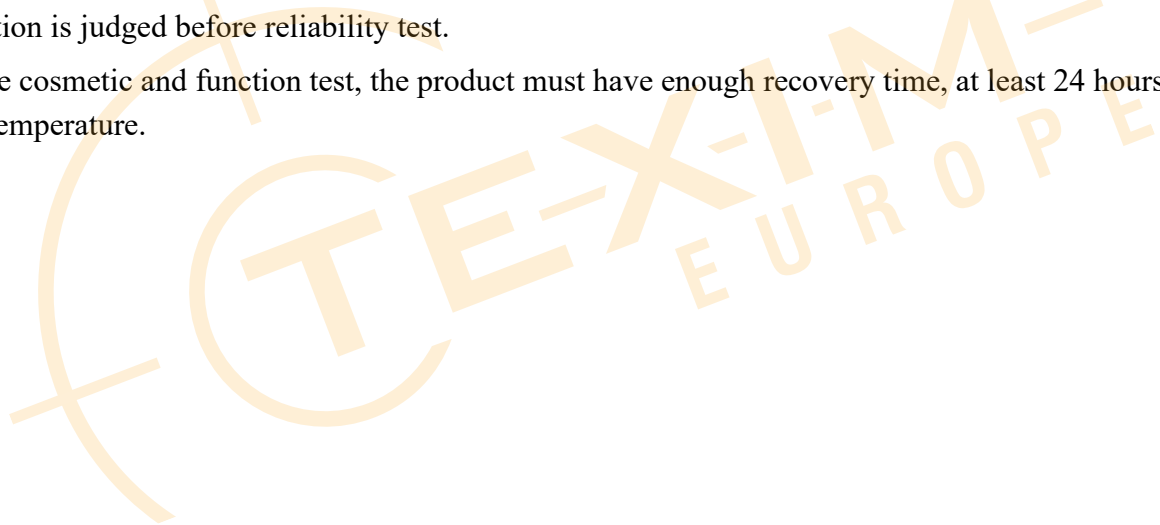

8 Appearance Inspection

8.1 Inspection Sampling Method:

Unless there is other agreement, the sampling plan for incoming inspection shall follow GB2828.1-2012.

- (1) Lot size: Quantity per shipment as one lot (different model as different lot).
- (2) Sampling type: Normal inspection, single sampling.
- (3) Sampling level: Level II.

8.2 Inspection Conditions

The environmental condition and visual inspection shall be conducted as below:

- (1) Light: 800~1400Lux;
- (2) Vision requirement: Naked or corrected vision of at least 1.0 and no color blindness;
- (3) Inspection background: black and white board is used as the background below the product;
- (4) Inspection distance: 30~40cm from human eyes to the measured surface;
- (5) Inspection Angle: the detected surface is 90 degree from to line of sight, and the measured Object should be rotated 45 degree from side to side;
- (6) Inspection time: 5~10s;

8.3 Inspection equipment

Secondary elements, calipers, feelers, filinka, petroleum ether, ND filter

8.4 Defect code comparison table



Code	Name (Unit)	Code	Name (Unit)
N	Number	D	Diameter (mm)
L	Length (mm)	H	Depth (mm)
W	Width (mm)	S	Distance (mm)
S	Area (mm ²)		

8.5 Inspection precautions

- (1) Inspectors must wear finger gloves and electrostatic bracelets.
- (2) Place the inspected product in front of the inspector, and hold the edge of the product with both hands carefully. Do not bend the product.

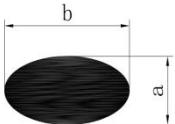
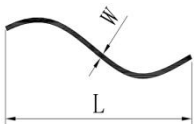
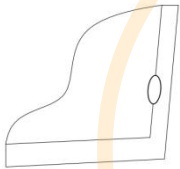
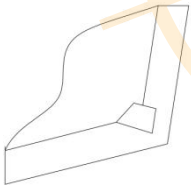
8.6 Inspection items and standards

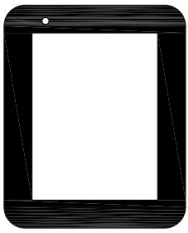
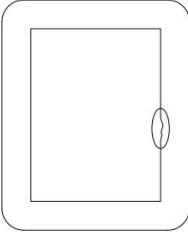
Items	Standard	Conclusion	Inspection tools
Dot (white, black, heterochromatic)  $D=(a+b)/2$	$D \leq 0.3$	Ignore, dense density is not allowed	Visual inspection
	$0.3 < D \leq 0.6$	The distance with another dot is more than 5 mm, Transparent areas : $N \leq 3$, Ink areas : $N \leq 5$	
	$D > 0.6$	Not allow	
Linear defects (fibers/foreign bodies/ scratches, etc.) 	$W \leq 0.08$	Ignore, dense density is not allowed	Visual inspection
	$0.08 < W \leq 0.15$	$L \leq 10$, the distance with another scratch or impurity is more than 5mm Transparent areas : $N \leq 3$, Ink areas : $N \leq 5$	
	$W > 0.15, L > 10$	Not allow	
Bubble	According to the point standard		Visual inspection
Edge broken loss 	<ol style="list-style-type: none"> The sensor edge creaks, without damaging the line. The function test is OK for reception, and the front side is not visible after fitting. Edge creak on front of cover plate: NG. Back $X < 0.5\text{mm}$; $Y < 0.5\text{mm}$; $Z < 1/3GT$ ($GT = \text{glass thickness}$), without affecting the functionality of the product, each side is allowed two 		Visual inspection
Corner broken loss 			

Items	Standard	Conclusion	Inspection tools
Creak	Creaks found at any location are not allowed		Visual inspection
Size	Meet the requirements of finished product inspection drawings		
Ink pinhole 	$D \leq 0.15$	Ignore, dense density is not allowed	
	$0.15 < D \leq 0.15$	$N \leq 5$ $DS \geq 10mm$, Repair with a paint pen of the same color as the cover plate	
Ink sawtooth 	$W \leq 0.2mm$	Ignore, dense density is not allowed	
Newton's rings	No more than 1/6 of the display area, light up invisible. If there are special requirements, the limited sample shall prevail.		
FPC 	<ol style="list-style-type: none"> 1. Oxidation, breakage, residual glue, coating peeling, cracking and other phenomena of FPC gold fingers are not allowed. 2. Less components, false welding, deformation are not allowed. 		
Color	Consistent with the sample, no serious color difference		
Mura/Waving/ Hot spot	Not visible through 5% ND filter		

9 Notices

9.1 Cautions for storage

Store the module in a dark room where must keep at $25\pm 10^{\circ}\text{C}$ and 65%RH or less. Don't expose the products to the direct sunlight or stresses.

9.2 Cautions for operation

- (1) Do not put a heavy, hard or sharp object on the product.
- (2) Do not bend the product in order to assure the reliability.
- (3) Do not put one product on the other. Otherwise, the product to may be scratched or be changed.
- (4) Do not oile the touch panel, Do not put heavy goods on the touch panel.
- (5) Do not use any organic solvent acid or alkali solution to clean the surface of the product. Please use dry clothes or soft clothes with ethanol to clean the surface.

9.3 Cautions for operation

Light transmission is an important factor for the product. So, please wear clean finger sacks, gloves and mask to protect the products from fingerprint or stain attach, and also must ensure the area where your finger touches is outside the view area when handing the panel.

9.4 Others

- (1) Please note that dew gathering in the panel due to abrupt temperature or humidity change, etc. Which may cause deterioration of performance.
- (2) When this product was built into the package, if there is vulcanization material such as vulcanized rubber which has a possibility of generating the salutation gas near the package since abnormalities will be caused to wring of the product and it will become the cause if functional degradation, please give a constitutional cations.
- (3) Cation for product safety set

Although full care is taken to ensure product quality, failure modes such as degradation, short circuits, or open circuits might be caused, Therefore, to design a product set, please study the effects of any single failure of the panel in advance and consider the safety of product configuration.

Quality function livers for on year, outward appearance haves non-color variation in six months.

Disclaimer

ALL PRODUCTS, PRODUCT SPECIFICATIONS AND DATA ARE SUBJECT TO CHANGE WITHOUT NOTICE TO IMPROVE RELIABILITY, FUNCTION OR DESIGN OR OTHERWISE.

Texim Europe B.V. its affiliates, agents, and employees, and all persons acting on its or their behalf (collectively, "Texim"), disclaim any and all liability for any errors, inaccuracies or incompleteness contained in any datasheet or in any other disclosure relating to any product.

Texim makes no warranty, representation or guarantee regarding the suitability of the products for any particular purpose or the continuing production of any product.

It is the customer's responsibility to validate that a particular product with the properties described in the product specification is suitable for use in a particular application.

Parameters provided in datasheets and / or specifications may vary in different applications and performance may vary over time.

All operating parameters, including typical parameters, must be validated for each customer application by the customer's technical experts.

Please contact us if you have any questions about the contents of the datasheet.

This may not be the latest version of the datasheet. Please check with us if a later version is available.

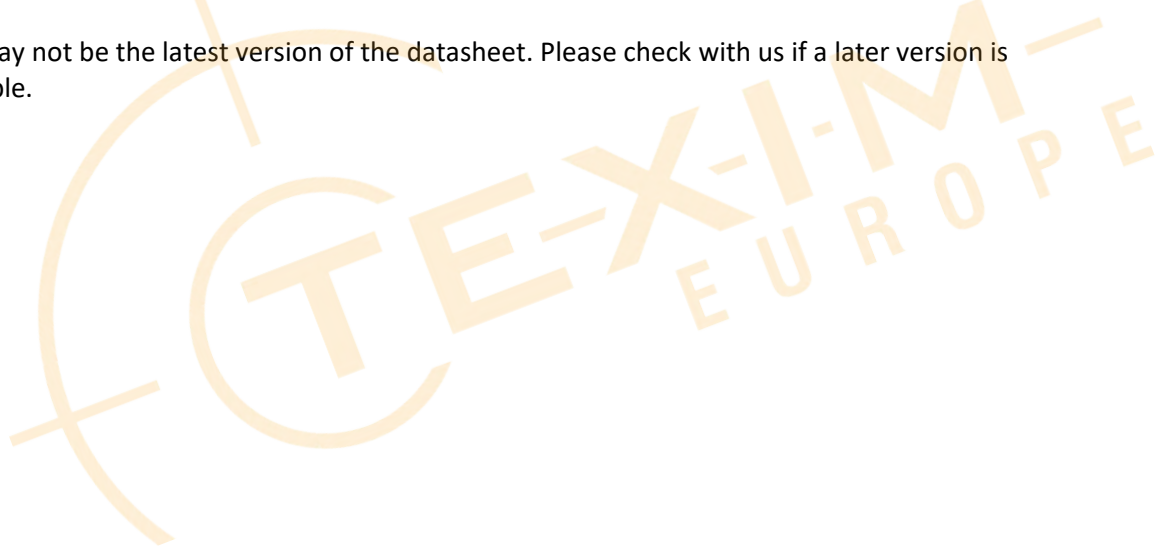



Headquarters & Warehouse

Elektrostraat 17
 NL-7483 PG Haaksbergen
 The Netherlands

T: +31 (0)53 573 33 33
 E: info@texim-europe.com
 Homepage: www.texim-europe.com



The Netherlands

Elektrostraat 17
 NL-7483 PG Haaksbergen

T: +31 (0)53 573 33 33
 E: nl@texim-europe.com



Belgium

Zuiderlaan 14, box 10
 B-1731 Zellik

T: +32 (0)2 462 01 00
 E: belgium@texim-europe.com



UK & Ireland

St Mary's House, Church Lane
 Carlton Le Moorland
 Lincoln LN5 9HS

T: +44 (0)1522 789 555
 E: uk@texim-europe.com



Germany

Bahnhofstrasse 92
 D-25451 Quickborn

T: +49 (0)4106 627 07-0
 E: germany@texim-europe.com



Germany

Martin-Kollar-Strasse 9
 D-81829 München

T: +49 (0)89 436 086-0
 E: muenchen@texim-europe.com



Austria

Martin-Kollar-Strasse 9
 D-81829 München

T: +49 (0)89 436 086-0
 E: austria@texim-europe.com



Nordic

Stockholmsgade 45
 2100 Copenhagen

T: +45 88 20 26 30
 E: nordic@texim-europe.com



Italy

Martin-Kollar-Strasse 9
 D-81829 München

T: +49 (0)89 436 086-0
 E: italy@texim-europe.com