

Distributed by:



www.texim-europe.com

MEC-WIFI-M231B-H

Mini PCIe Wireless 802.11 a/b/g/n/ac 1T1R BT 4.0

Product Datasheet

Date: 2015.12.07

Revision: 1.0

File: MEC_WIFI_M231B_H_Datasheet_Rev1.0

Revision History

Date	Revision	Description
2015.12.07	1.0	First Released

Table of Contents

- Product Features.....4
- General Specification.....5~6
- Software and OS Support.....7
- Block Diagram.....7
- Mechanical Drawing.....8

Product Features

- Combo module compatible with IEEE802.11a/b/g/n/acdraft2.0 1T1R and BT4.0 + BLE
- Complies with PCI Express Base Specification Revision 1.1 for WLAN
- Complies with USB1.1 Specification for Bluetooth
- PCIe LTR/OBFF/L1.Off state supported
- 72.2Mbps receive PHY rate and 72.2 Mbps transmit PHY rate using 20Mhz bandwidth
- 150Mbps receive PHY rate and 150Mbps transmit PHY rate using 40MHz bandwidth
- 433.3Mbps transmit/receive PHY rate using 80Mhz bandwidth
- 802.11ac Draft 2.0 compatible WLAN
- 802.11e QoS Enhancement(WMM)
- 802.11i(WPA, WPA2). Open, shared key, and pair-wise key authentication services
WAPI supported
- Frame aggregation for increased MAC efficiency (A-MSDU,A-MPDU)
- Low latency immediate High-Throughput Block Acknowledgement(HT-BA)
- PHY-level spoofing to enhance legacy compatibility
- Multi MAC ID support with Fast Channel switch
- Channel management and co-existence
- Transmit Opportunity (TXOP) Short Inter-Frame Space (SIFS) bursting for higher multimedia bandwidth
- WiFi Direct supports wireless peer to peer applications
- Support Wake-On-Wlan via Magic Packets and Wake-up frames
- Support S3/S4 AES/TKIP group key update
- Support Win8 Network List Offload
- CCA on secondary through RTS/ CTS handshake
- Support TCP/UDP/IP checksum offload
- Integrated MCU to execute Bluetooth protocol stack

General Specification

Product Specification					
Solution	Realtek RTL8821AE				
Configuration	WLAN/ BT antenna diversity with DPDT RF switch				
WLAN					
WLAN Standard	IEEE 802.11 ABGN/AC				
Host interface	Half Mini-Card complies with PCI express 1.1				
PCIe VID	10EC				
PCIe DID	8821				
PCIe SVID	10EC				
PCIe SSID	8821				
Region Domain	2G_Worldwide13/5G_US_5G				
MP kit version	Updated by Realtek				
Antenna connectors	2 miniature coaxial RF connectors				
● Dimensions					
		Minimum	Typical	Maximum	Unit
	Length	29.85	30	30.15	mm
	Width	21.85	22	22.15	mm
	Height	2.1	2.35	2.6	mm
	Weight		TBD		g
Antenna Connector	2 Ultra-Miniature coaxial RF connectors				
● Operating Condition					
		Minimum	Typical	Maximum	Unit
Operation voltage	DC	3.15	3.3	3.45	V
Operation temperature		0		70	°C
Storage temperature		-20		70	°C
Humidity Non-Operating		10		80	%
● Electrical Specification					
Frequency range	2.4GHz and 5GHz band				
● Output power					
2.4G Band		Minimum	Typical	Maximum	Unit
802.11b Mode	11MHz	13	15	17	dBm
802.11g Mode	54MHz	12	14	16	dBm
802.11n Mode	HT20-MCS7	10	12	14	dBm
802.11n Mode	HT40-MCS7	9	11	13	dBm

5G Lower/ Middle Band		Minimum	Typical	Maximum	Unit
802.11a Mode	54MHz	9	11	13	dBm
802.11n Mode	HT20-MCS7	9	11	13	dBm
802.11n Mode	HT40-MCS7	7	9	11	dBm
802.11ac Mode	VHT80-MCS9	5	7	9	dBm
5G Upper Band		Minimum	Typical	Maximum	Unit
802.11a Mode	54MHz	6	8	10	dBm
802.11n Mode	HT20-MCS7	6	8	10	dBm
802.11n Mode	HT40-MCS7	6	8	10	dBm
802.11ac Mode	VHT80-MCS9	4	6	8	dBm
● Receiver Sensitivity					
2.4G Band		Minimum	Typical	Maximum	Unit
802.11b Mode	11Mbps			-70	dBm
802.11g Mode	54Mbps			-65	dBm
802.11n Mode	HT20 MCS7			-64	dBm
802.11n Mode	HT40 MCS7			-61	dBm
5G Band		Minimum	Typical	Maximum	Unit
802.11a Mode	54MHz			-65	dBm
802.11n Mode	HT20-MCS7			-64	dBm
802.11n Mode	HT40-MCS7			-61	dBm
802.11ac Mode	VHT80-MCS9			-51	dBm
● Bluetooth					
Radio Standard	Bluetooth Class II v4.0				
Host interface	USB2.0				
USB VID	0BDA				
USB PID	8821				
Frequency Band	2400-2483.5 MHz				
Data Rate	Up to 2169kbps				
Channel	79 sub-channels				
Transmission	FHSS (Frequency Hopping Spread Spectrum)				
Modulation	GFSK@1Mbps; $\pi/4$ DQPSK@2Mbps; 8DPSK@3Mbps				
Output Power	-6 ~ +4dBm				
Max Input Level	0dBm				
Receiver Sensitivity	-70dBm				

Software and OS Support

- Windows 7 , Windows 8 , Windows 8.1 , Windows 10
- Linux (kernel 2.6.24 ~ 3.10.10 ; 4.3.8)
- Android 1.6 ~ 2.3 ; 4.0~4.3 ; 4.4

Block Diagram

RTL8821AE Block Diagram

Dual-Band 11ac (1x1) Solution (11ac 1x1 MAC/BB/RF) with Integrated Bluetooth Controller and Antenna Diversity

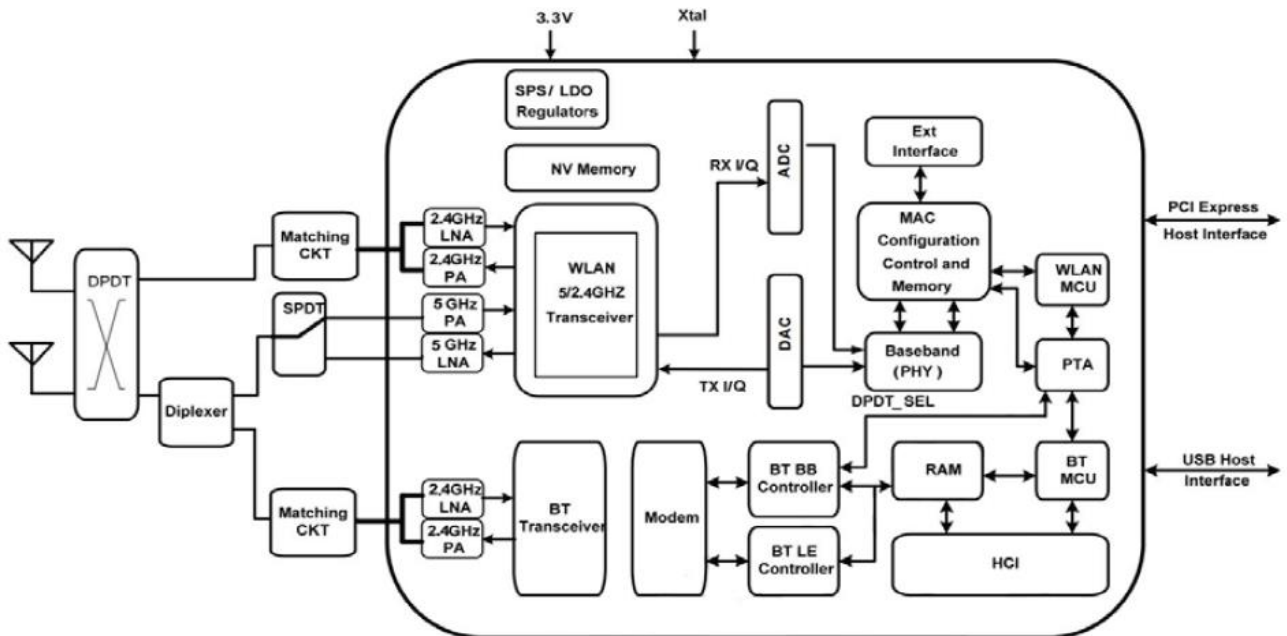

Mechanical Drawing

