



SIM8202E-M2

Hardware Design

5G Module



SIMCom Wireless Solutions Limited

SIMCom Headquarters Building, Building 3, No. 289 Linhong Road, Changning District, Shanghai P.R. China

Tel: 86-21-31575100

support@simcom.com

www.simcom.com

Document title:	SIM8202E-M2 Hardware Design
Version:	V1.02
Date:	2021-06-28
Status:	Released

GENERAL NOTES

SIMCOM OFFERS THIS INFORMATION AS A SERVICE TO ITS CUSTOMERS TO SUPPORT THE APPLICATION AND ENGINEERING EFFORTS THAT USE THE PRODUCTS DESIGNED BY SIMCOM. THE INFORMATION PROVIDED IS BASED ON THE REQUIREMENTS SPECIFICALLY FROM THE CUSTOMERS. SIMCOM HAS NOT UNDERTAKEN ANY INDEPENDENT SEARCH FOR ADDITIONAL RELEVANT INFORMATION, INCLUDING ANY INFORMATION THAT MAY BE IN THE CUSTOMER'S POSSESSION. FURTHERMORE, THE SYSTEM VALIDATION OF THE PRODUCT DESIGNED BY SIMCOM WITHIN A LARGER ELECTRONIC SYSTEM REMAINS THE RESPONSIBILITY OF THE CUSTOMER OR THE CUSTOMER'S SYSTEM INTEGRATOR. ALL SPECIFICATIONS SUPPLIED HEREIN ARE SUBJECT TO CHANGE WITHOUT NOTICE.

COPYRIGHT

THIS DOCUMENT CONTAINS THE PROPRIETARY TECHNICAL INFORMATION WHICH IS THE PROPERTY OF SIMCOM LIMITED, COPYING OF THIS DOCUMENT, GIVING IT TO OTHERS, THE USING OR COMMUNICATION OF THE CONTENTS THEREOF ARE FORBIDDEN WITHOUT THE OFFICIAL AUTHORITY BY SIMCOM. OFFENDERS ARE LIABLE TO THE PAYMENT OF THE DAMAGES. ALL RIGHTS ARE RESERVED IN THE EVENT OF GRANT OF A PATENT OR THE REGISTRATION OF A UTILITY MODEL OR DESIGN. ALL SPECIFICATIONS SUPPLIED HEREIN ARE SUBJECT TO CHANGE WITHOUT NOTICE.

SIMCom Wireless Solutions Limited

Building B, SIM Technology Building, No.633 Jinzhong Road, Changning District, Shanghai P.R.China

Tel: +86 21 31575100

Email: SIMcom@SIMcom.com

For more information, please visit:

<https://www.SIMcom.com/download/list-863-en.html>

For technical support, or to report documentation errors, please visit:

<https://www.SIMcom.com/ask/> or email to: support@SIMcom.com

Copyright © 2020 SIMCom Wireless Solutions Limited All Rights Reserved.

Version History

Data	Version	Description of change	Author
2021-03-16	1.00	Initial release	Olivier.wu Yuqing.xiong Yao.chen
2021-05-31	1.01	Update frequency data	Yuqing.xiong
2021-06-28	1.02	Update current consumption Update Receive Sensitivity	Yao.chen Yuqing.xiong



Contents

1	Introduction.....	9
1.1	Product Outline.....	9
1.2	Hardware Block Diagram.....	10
1.3	Feature Overview.....	11
2	Package Information.....	13
2.1	Pin Assignment Overview.....	13
2.2	Pin Description.....	14
2.3	Mechanical Dimensions.....	18
3	Interface Application.....	19
3.1	Power Supply.....	19
3.1.1	Power Supply Design Guide.....	19
3.1.2	Recommended Power Supply Circuit.....	21
3.1.3	Voltage Monitor.....	23
3.2	Power On and Off Module.....	23
3.2.1	Power On.....	24
3.2.2	Power Off.....	25
3.3	Reset Function.....	26
3.4	I2C Interface.....	28
3.5	WoWWAN#*.....	29
3.6	USB Interface.....	30
3.7	PCIe Interface.....	33
3.8	(U)SIM Interface.....	35
3.9	I2S Interface.....	37
3.9.1	I2S Timing.....	38
3.9.2	I2S Reference Circuit.....	39
3.10	DPR*.....	41
3.11	CONFIG Pins.....	42
3.12	LED1#.....	42
3.13	W_DISABLE1#.....	44
3.14	TDD_SYNC_PPS*.....	45
3.15	W_DISABLE2#.....	47
3.16	Antenna Control Interface*.....	48
3.17	UART Interface.....	49
3.18	GPIOs Interface.....	50
4	Antenna Interfaces.....	51
4.1	Antenna Definitions.....	51
4.1.1	3G/4G/5G Operating Frequency.....	52
4.1.2	GNSS Frequency.....	54
4.2	Antenna Installation.....	54

4.2.1	Antenna Requirements.....	54
4.2.2	Antenna Tuner.....	55
4.2.3	RF Plug Recommendation.....	58
5	Electrical Specifications.....	60
5.1	Absolute Maximum Ratings.....	60
5.2	Operating Conditions.....	60
5.3	Operating Mode.....	61
5.3.1	Operating Mode Definition.....	61
5.3.2	Sleep Mode.....	62
5.3.3	Minimum Functionality Mode and Flight Mode.....	62
5.4	Current Consumption.....	63
5.5	RF Output Power.....	66
5.6	Conducted Receive Sensitivity.....	67
5.7	Thermal Design.....	69
5.8	ESD.....	71
6	Appearance.....	72
6.1	Top and Bottom View of SIM8202E-M2.....	72
6.2	Label Description Information.....	72
7	Packaging.....	74
8	Appendix.....	76
8.1	Coding Schemes and Maximum Net Data Rates over Air Interface.....	76
8.2	Related Documents.....	78
8.3	Terms and Abbreviations.....	79
8.4	Safety Caution.....	81

Table Index

Table 1: SIM8202E-M2 frequency bands.....	9
Table 2: Key features.....	11
Table 3: IO parameters definition.....	14
Table 4: DC parameters definition.....	14
Table 5: Pin description.....	15
Table 6: VBAT pins electrical characteristics.....	19
Table 7: Definition of VBAT and GND pins.....	20
Table 8: Recommended D1 and D2 list.....	21
Table 9: Recommended ferrite bead FB1.....	22
Table 10: Definition of FULL_CARD_POWER_OFF# pin.....	24
Table 11: Power on timing and electrical characteristics.....	24
Table 12: Power off timing and electrical characteristics.....	25
Table 13: Definition of RESET# pin.....	26
Table 14: RESET# pin electrical characteristics.....	27
Table 15: Definition of I2C interface.....	28
Table 16: Definition of WoWWAN# pin.....	29
Table 17: Definition of USB interface.....	31
Table 18: USB interface recommended CC detector, USB3.1 type-C switch and TVS diode list.....	32
Table 19: Definition of PCIe interface.....	34
Table 20: PCIe interface recommended TVS diode list.....	34
Table 21: (U)SIM electrical characteristics in 1.8V mode ((U)SIM_PWR=1.8V).....	35
Table 22: (U)SIM electrical characteristics in 3.0V mode ((U)SIM_PWR=3.0V).....	35
Table 23: Definition of (U)SIM interface.....	36
Table 24: Recommended TVS and (U)SIM socket list.....	37
Table 25: I2S format.....	37
Table 26: I2S timing parameters.....	38
Table 27: Definition of I2S interface.....	39
Table 28: The PCM interface is multiplexing with I2S interface.....	39
Table 29: Definition of DPR# pin.....	41
Table 30: CONFIG pins state of the module.....	42
Table 31: CONFIG interface definition.....	42
Table 32: Definition of LED1# pin.....	43
Table 33: LED1# pin status.....	43
Table 34: Definition of W_DISABLE1# pin.....	44
Table 35: W_DISABLE1# pin status.....	44
Table 36: Definition of TDD_SYNC_PPS pin.....	45
Table 37: Definition of W_DISABLE2# pin.....	47
Table 38: W_DISABLE2# pin status.....	47
Table 39: Definition of antenna control interface through GPIOs.....	48
Table 40: Definition of UART interface.....	49
Table 41: GPIO list.....	50

Table 42: Antenna port definitions.....	51
Table 43: SIM8202E-M2 frequency band and antenna ports mapping.....	52
Table 44: The module operating frequency.....	52
Table 45: GNSS frequency.....	54
Table 46: 3G/4G/5G/GNSS antennas.....	54
Table 47: GNSS antenna (for dedicated GNSS antenna only)*.....	55
Table 48: Electrical Specifications of 20449-001E-03.....	59
Table 49: Absolute maximum ratings.....	60
Table 50: VBAT recommended operating ratings.....	60
Table 51: 1.8V Digital I/O characteristics.....	60
Table 52: Operating temperature.....	61
Table 53: Operating mode definition.....	61
Table 54: Current consumption on VBAT pins (VBAT=3.8V).....	63
Table 55: Conducted output power.....	66
Table 56: Conducted RF receiving sensitivity.....	67
Table 57: The ESD performance measurement table (Temperature: 25°C, Humidity: 45%).....	71
Table 58: Label description of the module information.....	73
Table 59: Tray size.....	74
Table 60: Small carton size.....	75
Table 61: Big carton size.....	75
Table 62: Coding schemes and maximum net data rates over air interface.....	76
Table 63: Related documents.....	78
Table 64: Terms and abbreviations.....	79
Table 65: Safety caution.....	81

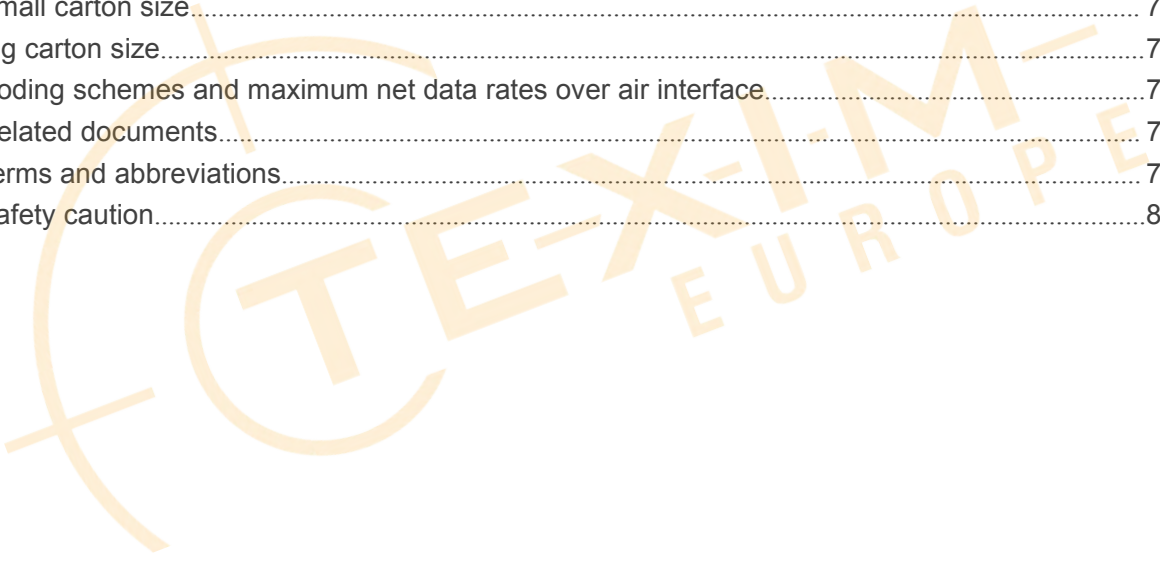

Figure Index

Figure 1: Block diagram.....	10
Figure 2: Pin assignment.....	13
Figure 3: Dimensions of the module (unit: mm).....	18
Figure 4: Power consumption at ENDC combination of B3 (20MHz) and N79 (100MHz).....	19
Figure 5: Power supply reference circuit.....	20
Figure 6: Linear regulator reference circuit.....	22
Figure 7: Switching mode power supply reference circuit.....	22
Figure 8: Reference power on/off circuit.....	23
Figure 9: Power on sequence.....	24
Figure 10: Power off sequence.....	25
Figure 11: Reference reset circuit.....	26
Figure 12: The reset timing sequence of the module.....	27
Figure 13: I2C reference circuit.....	28
Figure 14: WoWWAN# signal level at SMS and URC report.....	29
Figure 15: WoWWAN# reference circuit.....	29
Figure 16: USB reference circuit.....	30
Figure 17: Type-C USB reference circuit with CC detector.....	31
Figure 18: PCIe interface reference circuit (EP Mode).....	33
Figure 19: (U)SIM interface reference circuit.....	36
Figure 20: I2S timing.....	38
Figure 21: Audio codec diagram circuit.....	39
Figure 22: LED1# reference circuit.....	42
Figure 23: W_DISABLE1# pin reference circuit.....	44
Figure 24: TDD_SYNC_PPS pin reference circuit.....	45
Figure 25: W_DISABLE2#pin reference circuit.....	47
Figure 26: UART level conversion circuit.....	49
Figure 27: Antenna interfaces.....	51
Figure 28: Aperture tuner reference block diagram.....	56
Figure 29: Impedance tuner reference block diagram.....	56
Figure 30: Hybrid tuner reference block diagram.....	57
Figure 31: M.2 package Tuner mipi interface.....	57
Figure 32: LGA package Tuner mipi interface.....	58
Figure 33:3D view of 20449-001E-03.....	58
Figure 34: 3D view of 20449-001E-03.....	59
Figure 35: Thermal dissipation area on bottom side of the module.....	69
Figure 36: Top and bottom view of the module.....	72
Figure 37: Label description of the module.....	72
Figure 38: Packaging procedures.....	74
Figure 39: Tray view of the module.....	74
Figure 40: Small carton view.....	75
Figure 41: Big carton view.....	75

1 Introduction

This document describes the electronic specifications, RF specifications, interfaces, mechanical characteristics and test results of the SIM8202E-M2 module. With the help of this document, customers can quickly understand SIM8202E-M2 module.

Associated with other software application notes and user guides, customers can use SIM8202E-M2 to design and develop mobile and laptop applications easily.

1.1 Product Outline

SIM8202E-M2 is a wireless communication module focusing on 5G market; it supports multi-air access technology including 5G NR (NSA/SA), LTE-FDD, LTE-TDD, and WCDMA, can meet the 3GPP R15 NR specification, and data rate which up to 2.4Gps.

The module's supported radio frequency bands are shown in the following table.

Table 1: SIM8202E-M2 frequency bands

Standard	Frequency bands
5G NR	n1/n3/n5/n7/n8/n12/n20/n28/n38/n40/n41/n48/n71/n77/n78/79
LTE-FDD	B1/B3/B4/B5/B7/B8/B12/B13/B14/B17/B18/B19/B20/B26/B28/B29/B71
LTE-TDD	B34/B38/B39/B40/B41/B42/B43/B48
LAA	B46
WCDMA	B1/B3/B5/B8
GNSS ¹	GPS L1+L5 dual bands/GLONASS/BeiDou/Galileo/QZSS

NOTE

1. GNSS is optional.
2. For the details information about the combination of ENDC, please contact SIMCom support teams.

The physical dimension of SIM8202E-M2 is 30.0mm*42.0mm*2.3mm, which can meet PCI Express M.2 specifications, and can meet almost all space requirements in customer's applications.

With M.2 Type 3042, SIM8202E-M2 owns rich interfaces, includes USB3.1, PCIe3.0, (U)SIM card, digital audio (I2S or PCM), I2C, GPIOs, four antennas for 3G/4G/5G and GNSS.

With all the interfaces, SIM8202E-M2 can also be utilized in the hand held terminal, machine-to-machine laptop application and especially the notebook.

1.2 Hardware Block Diagram

The block diagram of SIM8202E-M2 is shown in the following figure.

Power Supply:3.135V~4.4V

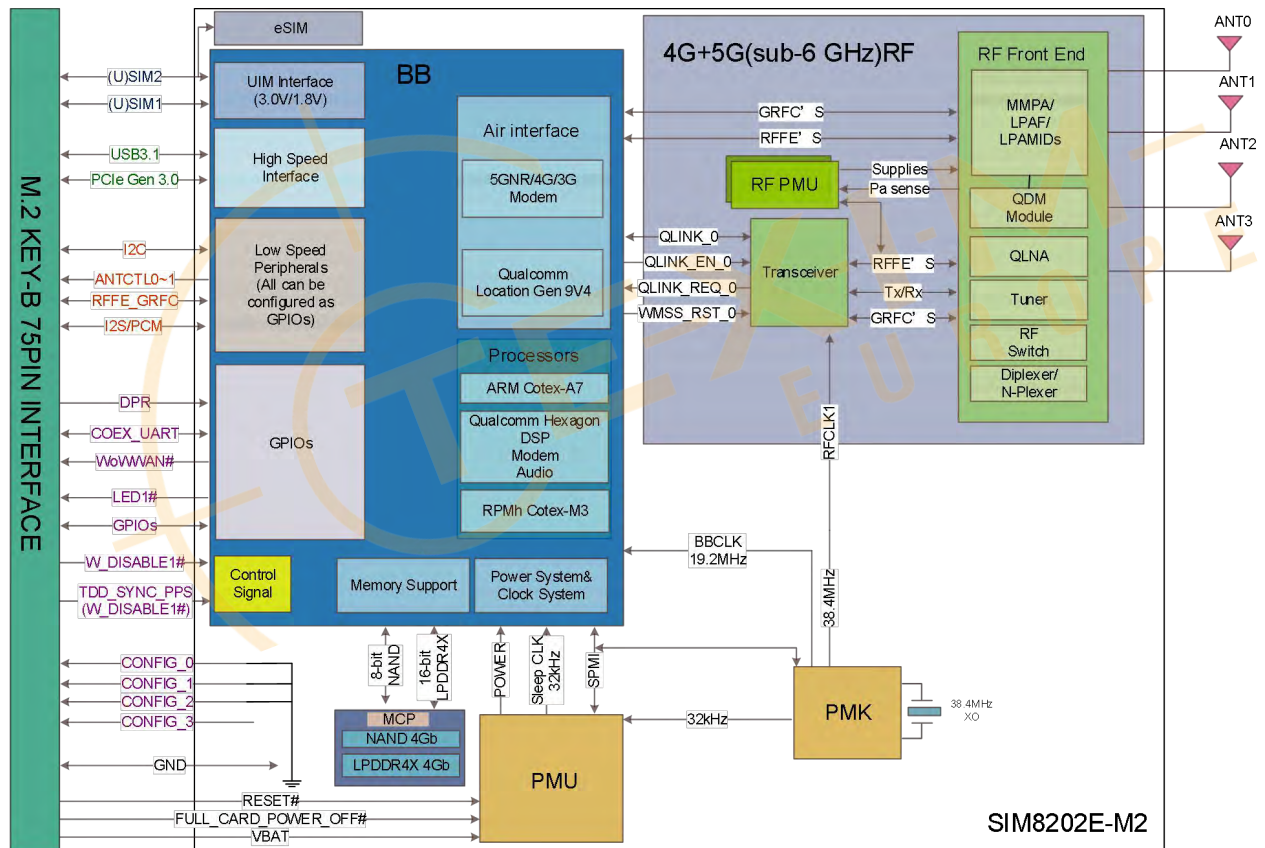

Figure 1: Block diagram

1.3 Feature Overview

Table 2: Key features

Feature	Implementation
Power supply ¹	VBAT:3.135~4.4V Typical: 3.8V
Power consumption*	Typical:5mA @sleep mode(VBAT=3.8V)*
Transmit power	Power Class 3 for WCDMA/LTE/5G NR Power Class 2 for n41/n78/n79
Data transmission throughput	2.4Gbps (DL)/500Mbps(UL) for NR 1Gbps (DL)/200Mbps (UL) for LTE 42Mbps(DL)/5.76Mbps(UL) for HSPA+
Antenna	Four antennas for 3G/4G/5G and GNSS
GNSS(optional)	GNSS engine : GPS L1+L5/GLONASS/BeiDou/Galileo/QZSS Protocol: NMEA
SMS	MT, MO, CB, Text and PDU mode SMS storage: (U)SIM card or ME(default) Transmission of SMS alternatively over CS or PS
(U)SIM interface	Support (U)SIM card:1.8V/3.0V Include (U)SIM1 and (U)SIM2 interfaces Support dual (U)SIM single standby
(U)SIM application toolkit	Support SAT class 3 Support USAT
Phonebook management	Support phonebook types: DC,MC,RC,SM,ME,FD,ON,LD,EN
Digital audio interface	One I2S interface with dedicated main-clock for primary digital audio, the I2S also can be configured as PCM <ul style="list-style-type: none"> ● MCLK frequency: 12.288MHz (default) ● WCDMA AMR-NB ● VoLTE AMR-WB ● Echo Cancellation ● Noise Suppression
PCIe interface	<ul style="list-style-type: none"> ● One lane PCIe interface, support Gen 3 (Gen 1/2compatible) ● High communication data rate which up to 8Gbps
I2C interface	<ul style="list-style-type: none"> ● Meet I2C specification, version 5.0 ● Data rate up to 400Kbps
USB	Support USB 3.1 Gen2 or USB 2.0 USB3.1: super speed, with data rate which up to 10Gbps USB2.0:high speed interface, support USB operations at low-speed and full-speed, which refer to USB1.0 and USB1.1

UART interface	SIM8202E-M2 hardware configures as normal communication UART(AT command) by default
Firmware upgrade	Firmware upgrade over USB interface
Physical characteristics	Size: 30mm*42mm*2.3mm Weight: TBD
Temperature range	Normal operation temperature: -30°C to +70°C 3GPP compliant Extended operation temperature: -40°C to +85°C ³ Storage temperature: -40°C to +90°C

NOTE

1. The recommended operating voltage of the module is 3.8V. If the voltage is lower than 3.3V, the RF performance may deviate from the 3GPP specifications.
2. “*” means under development.
3. The module is able to establish and maintain voice, data transmission, SMS and emergency call, etc. The performance may deviate slightly from the 3GPP specifications and will meet 3GPP specifications again when the temperature returns to normal operating temperature levels.



2 Package Information

2.1 Pin Assignment Overview

SIM8202E-M2 has 75 pins, including 8 notch pins. Customer design should match pins functions. The following figure is the pin assignment of the module.

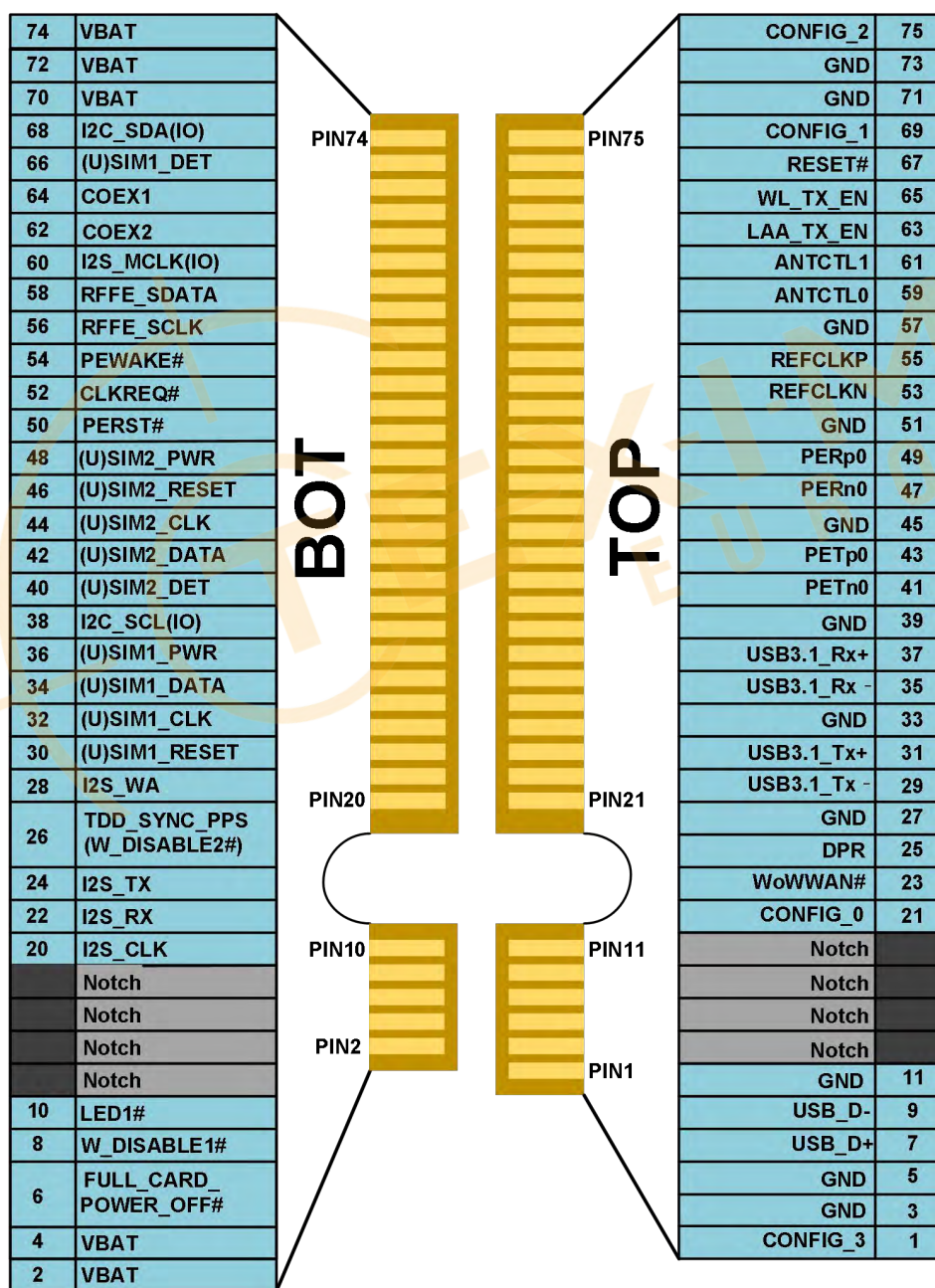

Figure 2: Pin assignment

2.2 Pin Description

Table 3: IO parameters definition

Pin type	Description
PI	Power Input
PO	Power Output
AI	Analog Input
AIO	Analog Input /Output
DIO	Digital Input /Output
DI	Digital Input
DO	Digital Output
DOH	Digital Output with High level
DOL	Digital Output with Low level
PU	Pull Up
PD	Pull Down
OD	Open Drain
OC	Open Collector
pdpukp	pd: nppukp = default pull-down with programmable options following the colon pu: nppdkp = default pull-up with programmable options following the colon kp: nppdpu = default keeper with programmable options following the colon

Table 4: DC parameters definition

Voltage domain	Parameter	Min	Type	Max	
P3	VDD_P3=1.8V				
	V _{OH}	High level output	1.35V	-	1.8V
	V _{OL}	Low level output	0V	-	0.45V
	V _{IH}	High level input	1.26V	1.8V	2.1V
	V _{IL}	Low level input	0V	-	0.54V
	R _p	Pull up/down resistor	20K ohm	-	60K ohm
P4/P5	VDD_P4/P5=1.8V				
	V _{OH}	High level output	1.44V	-	1.8V
	V _{OL}	Low level output	0V	-	0.4V
	V _{IH}	High level input	1.26V	-	1.95V
	V _{IL}	Low level input	0V	-	0.36V
	R _p	Pull up/down resistor	10K ohm	-	100K ohm
	VDD_P4/P5=3.0V				
	V _{OH}	High level output	2.4V	-	3.0V
	V _{OL}	Low level output	0V	-	0.4V

	V _{IH}	High level input	2.1V	-	3.05V
	V _{IL}	Low level input	0V	-	0.6V
	R _p	Pull up/down	10K ohm		100K ohm

Table 5: Pin description

Pin name	Pin no.	Electrical description	Description	Comment
Power supply				
VBAT	2,4,70,72,74	PI	Power supply Range : 3.135~4.4V Typical : 3.8V	These pins should be connected together to withstand sufficient current
GND	3,5,11,27,33,39,45,51,57,71,73		Ground	
System control				
FULL_CARD_POWER_OFF#	6	DI,PD	High level: the module power on Low level: the module power off	It's 3.3V tolerant but can be driven by either 1.8V or 3.3V GPIO
RESET#	67	P3 DI,PU	System reset control input Active low	RESET# has been pulled up to 1.8V internally
W_DISABLE1#	8	DI	WWAN RF disable Active low	3.3V tolerant but can be driven by either 1.8V or 3.3V GPIO
TDD_SYNC_PPS (W_DISABLE2#)	26	P3 DO ,DI	W_DISABLE2# and TDD_SYNC_PPS function can compatible PIN26 of SIM8202E-M2	SIM8202E-M2 hardware support TDD_SYNC_PPS function by default
WoWWAN#	23	OD	Wake on the host Active low	
Configuration pins				
CONFIG_0	21	GND	Connected to ground internally	The module is configured as the WWAN USB3.1 interface type
CONFIG_1	69	GND	Connected to ground internally	
CONFIG_2	75	GND	Connected to ground internally	
CONFIG_3	1	NC	Not connected	
USB2.0/USB3.1				
USB_D+	7	AIO	Differential USB bi-directional data positive	Main communication interface
USB_D-	9	AIO	Differential USB bi-directional data negative	
USB3.1_Tx-	29	AO	USB3.1 transmit data negative	USB3.1 data rate up to 10Gbps USB2.0 data rate up to 480Mbps
USB3.1_Tx+	31	AO	USB3.1 transmit data positive	
USB3.1_Rx-	35	AI	USB3.1 receive data	

				negative	
USB3.1_Rx+	37		AI	USB3.1 receive data positive	
PCIe interface					
PETn0	41		AO	PCIe transmit data negative	Support PCIe Gen 3.0, data rate up to 8Gbps. If unused, please keep open
PETp0	43		AO	PCIe transmit data positive	
PERn0	47		AI	PCIe receive data negative	
PERp0	49		AI	PCIe receive data positive	
REFCLKN	53		AIO	PCIe reference clock negative	
REFCLKP	55		AIO	PCIe reference clock positive	
PCIe assistant interface					
PERST#	50		DI	PCIe reset signal Active low	3.3V voltage domain, CLKREQ# and PEWAKE# required pull up external Default as EP mode, If unused, please keep open
CLKREQ#	52		DIO	PCIe reference clock request signal Active low	
PEWAKE#	54		DIO	PCIe wake up control Active low	
(U)SIM interface					
(U)SIM1_PWR	36		PO	Power supply for (U)SIM1 card	1.8/3.0V voltage domain, (U)SIM interfaces should be protected against ESD If unused, please keep open
(U)SIM1_DATA	34	P4	DIO	(U)SIM1 card data, which has been pulled up to (U)SIM1_VDD via a 20KR resistor internally	
(U)SIM1_CLK	32	P4	DO	(U)SIM1 clock signal	
(U)SIM1_RESET	30	P4	DO	(U)SIM1 reset control	
(U)SIM1_DET	66	P3	DI	(U)SIM1 card detect, which has been pulled up to VDD_P3 via a 470KR resistor internally	
(U)SIM2_PWR	48		PO	Power supply for (U)SIM2 card	
(U)SIM2_DATA	42	P5	DIO	(U)SIM2 card data, which has been pulled up to (U)SIM2_VDD via a 20KR resistor internally	
(U)SIM2_CLK	44	P5	DO	(U)SIM2 clock signal	
(U)SIM2_RESET	46	P5	DO	(U)SIM2 reset control	
(U)SIM2_DET	40	P3	DI	(U)SIM2 card detect, which has been pulled up to VDD_P3 via a 470KR resistor internally	
Antenna control interface					
ANTCTL0	59	P3	DO	Antenna tuner control0	Refer to 4.2.2 Antenna tuner
ANTCTL1	61	P3	DO	Antenna tuner control1	
ANTCTL 2 (RFFE_SDATA) ³	58	P3	DO (DIO)	Antenna tuner control2 (Antenna tuner MIPI DATA) ³	1.8V voltage domain. If unused, please keep

ANTCTL3 (RFFE_SCLK) ³	56	P3	DO	Antenna tuner control3 (Antenna tuner MIPI CLK) ³	open
I2S interface					
I2S_CLK	20	P3	DO	I2S clock output	
I2S_RX	22	P3	DI	I2S data input	1.8V voltage domain, also can be used as PCM interface, If unused, please keep open
I2S_TX	24	P3	DO	I2S data output	
I2S_WA	28	P3	DO	I2S word alignment select (L/R)	
I2S_MCLK	60	P3	DO	I2S master clock	
I2C interface					
I2C_SDA	68	P3	DIO	I2C data signal	1.8V voltage domain, internal pulled up to 1.8V. If unused, please keep open
I2C_SCL	38	P3	DO	I2C clock signal	
Coex interface²					
COEX1* (COEX_TX*)	64	P3	DO	SIM8202E-M2 hardware configures as normal communication UART(AT command) by default	If need coexistence signal function, please contact SIMCom support teams
COEX2* (COEX_RX*)	62	P3	DI		
WL_TX_EN*	65	P3	DI	WiFi 5G TX indicator	If unused, please keep open
LAA_TX_EN*	63	P3	DO	n79 TX indicator	If unused, please keep open
Other pins					
LED1#	10		OD	The module status indicator via LED devices Active low	
DPR*	25	P3	DI	DPR (Dynamic Power Reduction) signal is used for SAR (Specific Absorption Rate) sensor interrupt input	
Notch					
Notch	12, 13, 14, 15, 16, 17, 18, 19			Notch	

NOTE

1. "*" means under development.
2. SIM8202E-M2 hardware configures as normal communication UART (AT command) by default, for more detail, please contact SIMCom support teams.
3. The RFFE signals are multiplexed with ANTCTL2 and ANTCTL3.

2.3 Mechanical Dimensions

The following figure shows the mechanical dimensions of SIM8202E-M2.

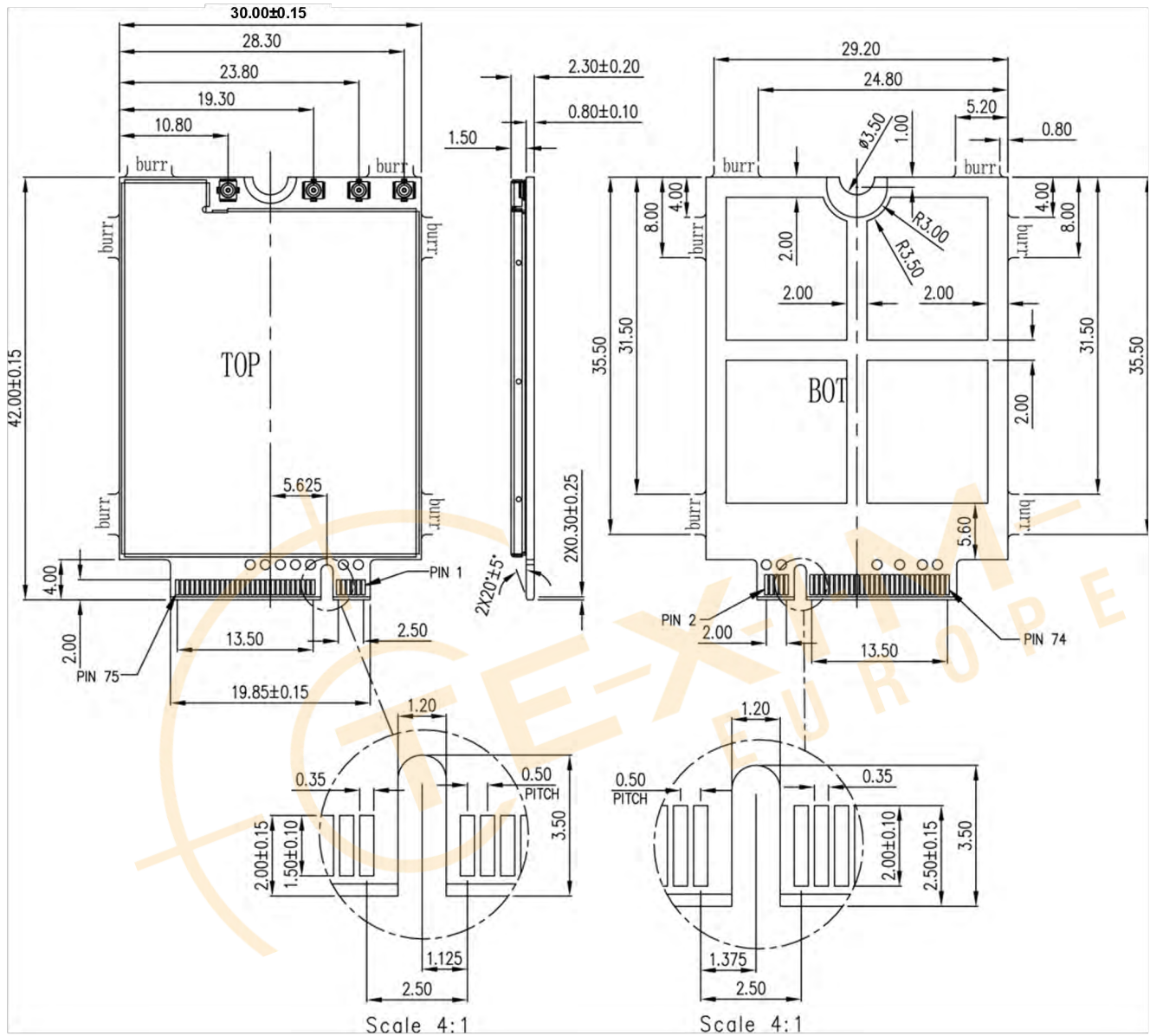

Figure 3: Dimensions of the module (unit: mm)

3 Interface Application

3.1 Power Supply

The recommended power supply of SIM8202E-M2 is 3.8V and power supply voltage ranges from 3.135 V to 4.4 V. Please make sure the input voltage will never drop below 3.135V, otherwise the module will be powered off automatically. The module has 5 power pins and 11 ground pins, make sure the module works properly, all power and ground pins should be connected.

Table 6: VBAT pins electrical characteristics

Symbol	Description	Min.	Typ.	Max.	Unit
VBAT	Module power supply voltage	3.135	3.8	4.4	V
I_{peak}	Peak current	-	-	1.8 ²	A
I_{sleep}	Current in sleep mode	-	5	-	mA
$I_{leakage}$	Current in power off mode	-	50	-	uA

3.1.1 Power Supply Design Guide

When B3 (20MHz) and N79 (100MHz) ENDC combination are connected under the instrument, the peak current can reach to 1.6A. In order to ensure the VBAT voltage is no less than 3.135V when the module at maximum power radio transmit, and considering the voltage drop and conversion efficiency, it is strongly recommend the DC-DC or LDO output capacity should not be less than 3A.

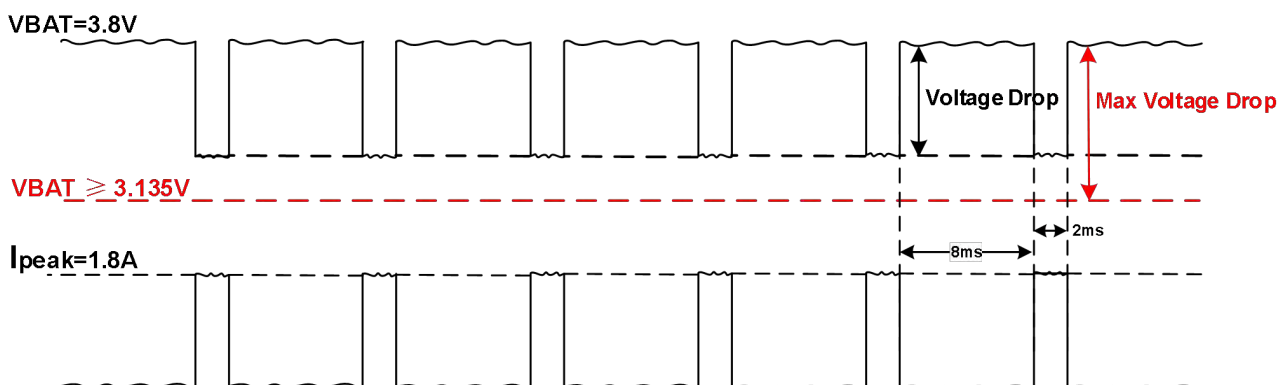

Figure 4: Power consumption at ENDC combination of B3 (20MHz) and N79 (100MHz)

NOTE

1. The total capacitors of VBAT net are not less than 420uF.
2. The I_{peak} and voltage drop data in Table 6 and Figure 4 were tested use SIMCom EVB and connect instrument, module power supply voltage is 3.8V, ENDC combination is B3 (20MHz) and N79 (100MHz), subcarrier spacing is 30KHz.
3. The B3 (20MHz) and N79 (100MHz) ENDC combination is the max power consumption of the module.
4. When the voltage drop on VBAT reaches its maximum value, please ensure that it minimum voltage is not less than 3.135V.

In order to decrease the voltage dropping, make sure the VBAT voltage no less than 3.135V and capacitors of VBAT net are not less than 420uF. The following figure shows VBAT net reference circuit of the module.

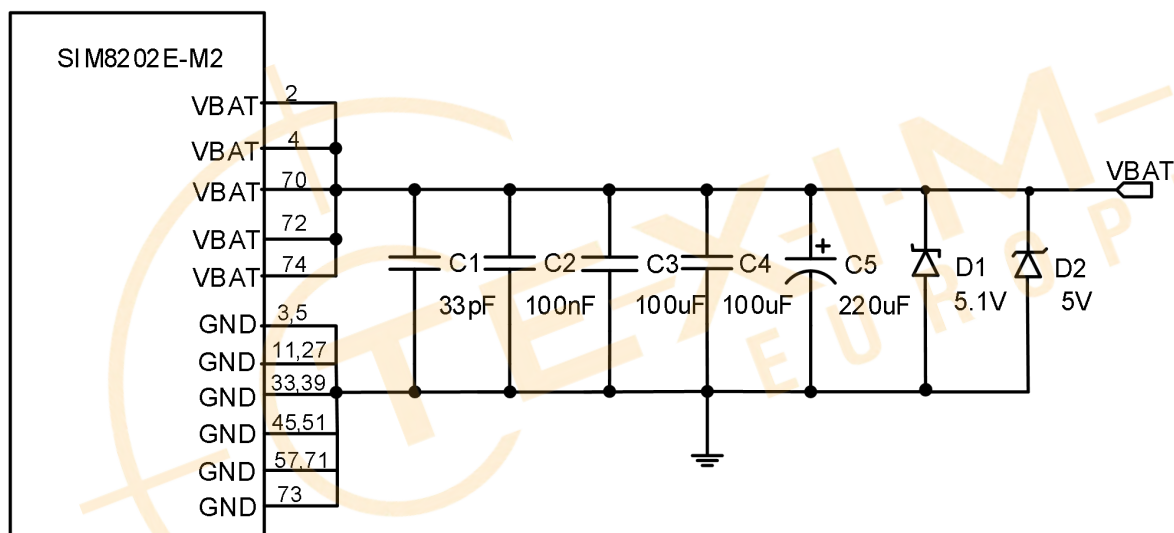

Figure 5: Power supply reference circuit

Table 7: Definition of VBAT and GND pins

Pin name	Pin no.	Electrical description	description	Comment
VABT	2,4,70,72,74	PI	Power supply Range : 3.135~4.4V Typical : 3.8V	These pins should be connected together to withstand sufficient current
GND	3,5,11,27,33,39,45,51,57,71,73		Ground	

In reference circuit, some multi-layer ceramic chip (MLCC) capacitors (0.1/1uF) with low ESR in high frequency band can be used for EMI suppression.

These capacitors should be put as close as possible to VBAT pins. Also, users should keep VBAT trace on circuit board wider than 3.0mm to minimize PCB trace impedance.

NOTE

1. C5 is 220 μ F tantalum capacitor, ESR=0.7 Ω .
2. C1 and C2 are multi-layer ceramic chip (MLCC) capacitors from 33pF to 1uF with low ESR in high frequency band, which can be used for EMC performance.
3. D2 is used for ESD protection and D1 is used for surge protection.

Table 8: Recommended D1 and D2 list

No.	Manufacturer	Part number	VRWM	Package	Ref. Designator
1	JCET	ESDBW5V0A1	5V	DFN1006-2L	D2
2	WAYON	WS05DPF-B	5V	DFN1006-2L	
3	LRC	LEDZ5.1BT1G	5.1V	SOD-523	D1
4	Prisemi	PZ5D4V2H	5.1V	SOD-523	

Power supply layout guidelines:

- Both VBAT and return trace should be as short and wide as possible to minimize the voltage dropping.
- The width of VBAT trace cannot be less than 3.0mm.
- These capacitors should be placed as closely as possible to VBAT pins.
- The VBAT trace should pass through TVS diode, zener diode and capacitors, and then VBAT pins. The capacitor of the small value should be placed close to VBAT pins.
- The PCB design must have a solid ground plane as the primary reference plane for most signals.

3.1.2 Recommended Power Supply Circuit

It is recommended to use a switching mode power supply or a linear regulator power supply. Make sure it can provide the current up to 3A at least.

Figure6 shows the linear regulator reference circuit with 5V input and 3.8V output.

Figure7 shows the switching mode power supply reference circuit with 5~12V input and 3.8V output.

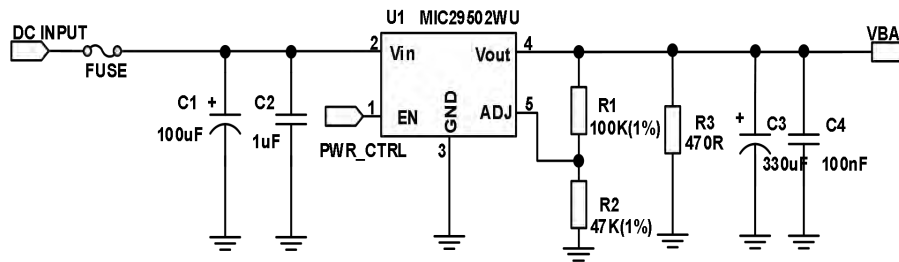

Figure 6: Linear regulator reference circuit

NOTE

An extra minimum load of R3 is required, to ensure it work properly under light load in sleep mode and power off mode. For the details about minimum load, please refer to specification of MIC29502WU.

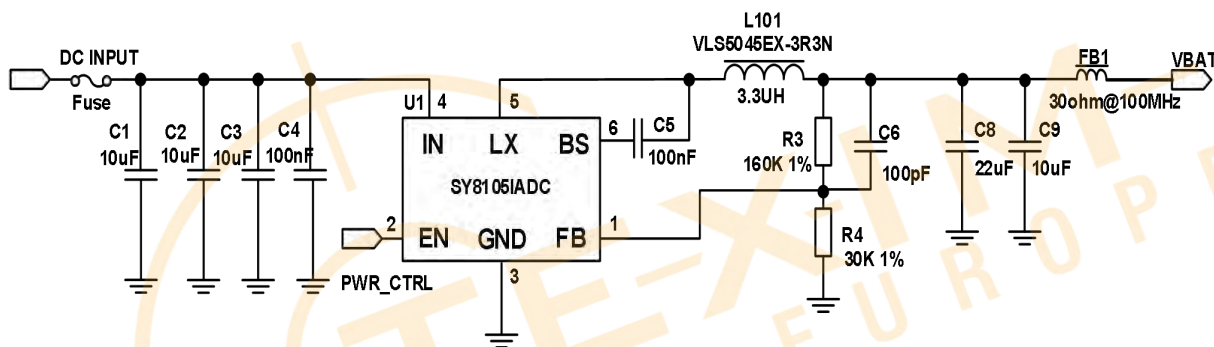

Figure 7: Switching mode power supply reference circuit

Table 9: Recommended ferrite bead FB1

Name	Manufacturer	Part number
Ferrite bead	Sunlord	UPZ1608E300-5R0TF

NOTE

1. In order to avoid damaging the module, please do not switch off the power supply when module works normally. Only after the module is shut down by FULL_CARD_POWER_OFF# or AT command, then the power supply can be cut off.
2. It is suggested that customer's design should have the ability to switch off the power supply for module in abnormal state, and then switch on the power to restart the module.
3. The PWR_CTRL signal recommend connect to the host and can be controlled.

3.1.3 Voltage Monitor

To monitor the VBAT voltage, the AT command “AT+CBC” can be used.

NOTE

For the details about voltage monitor commands, please refer to Document [1] in the appendix.

3.2 Power On and Off Module

Driving the FULL_CARD_POWER_OFF# pin to a high level, SIM8202E-M2 will be powered on. It can be driven by either 1.8V or 3.3V GPIO. The following figure shows the power on/off circuit.

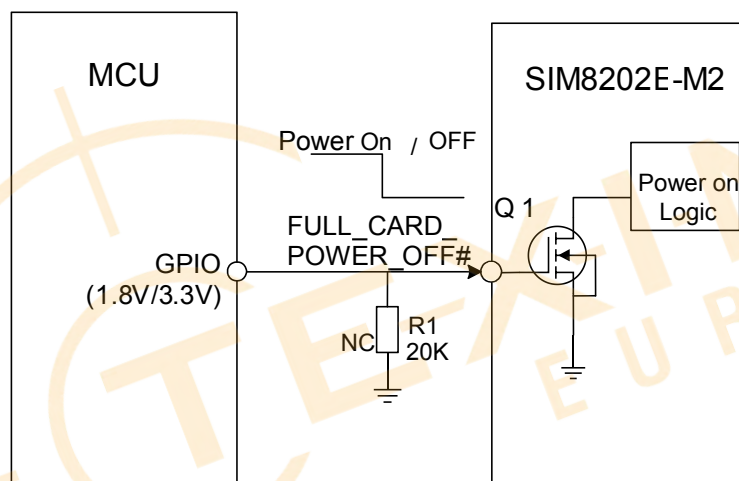

Figure 8: Reference power on/off circuit

NOTE

After the module enter force download mode, the FULL_CARD_POWER_OFF# signal need to release and don't pull high always. If not, the module will restart and then cause the download fail.

Table 10: Definition of FULL_CARD_POWER_OFF# pin

Pin name	Pin no.	Electrical description	description	Comment
FULL_CARD_POWER_OFF#	6	DI,PD	High level: the module powers on Low level: the module powers off	It's 3.3V tolerant but can be driven by either 1.8V or 3.3V GPIO

3.2.1 Power On

The power on sequence is shown in the following figure.

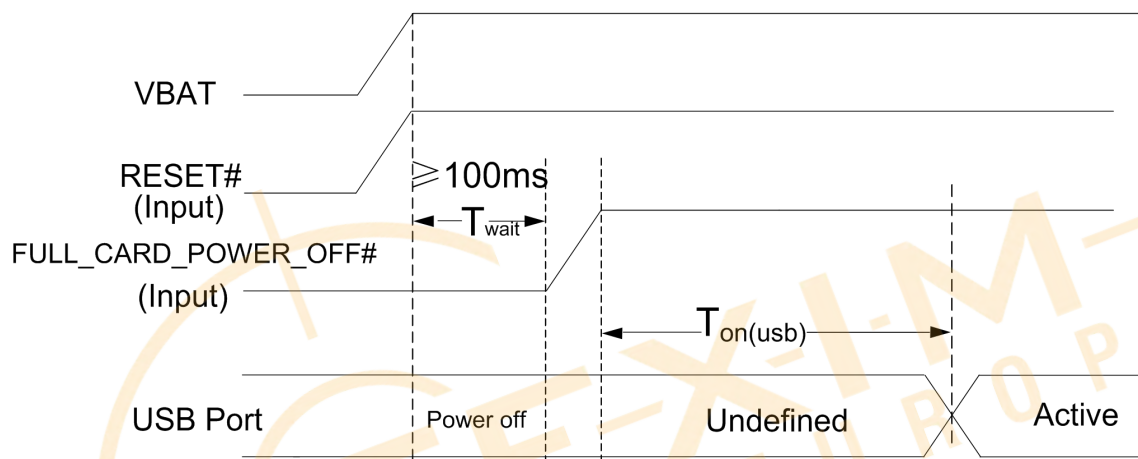

Figure 9: Power on sequence

Table 11: Power on timing and electrical characteristics

Symbol	Parameter	Min.	Typ.	Max.	Unit
T_{wait}	The waiting time from power supply available to power-on action	100	-	-	ms
$T_{\text{on(usb)}}$	The time from power-on action to USB port ready	-	13	-	s
V_{IH}	Input high level voltage on FULL_CARD_POWER_OFF# pin	1.2	1.8	4.4	V
V_{IL}	Input low level voltage on FULL_CARD_POWER_OFF# pin	0	-	0.2	V

3.2.2 Power Off

The following methods can be used to power off the module.

- Method 1: Power off the module by holding the FULL_CARD_POWER_OFF# pin to low level.
- Method 2: Power off module by AT command “AT+CPOF”.

NOTE

1. If the temperature is outside the range of $-30^{\circ}\text{C}\sim+70^{\circ}\text{C}$, some warning will be reported via AT port. If the temperature is outside the range of $-40^{\circ}\text{C}\sim+85^{\circ}\text{C}$, module will be powered off automatically. For the details about “AT+CPOF”, please refer to Document [1] in the appendix.
2. When the module is powered off by AT command, if the power supply not shut down and FULL_CARD_POWER_OFF# not be released, the module will automatically power on again.

Above normal power-off action will make the module disconnect from the network, allow the software to enter a safe state, and save key data before the module is powered off completely.

The power off sequence is shown in the following figure.

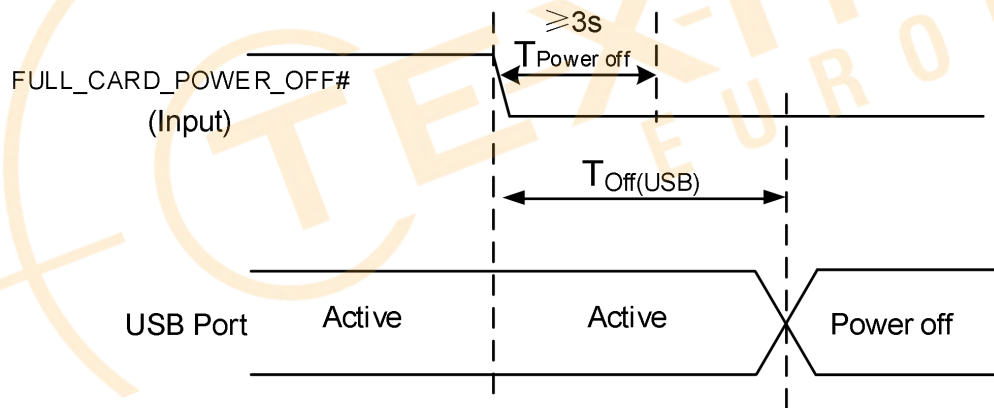

Figure 10: Power off sequence

Table 12: Power off timing and electrical characteristics

Symbol	Parameter	Time value			Unit
		Min.	Typ.	Max.	
$T_{\text{Off(USB)}}$	The time from power-off action to USB port off	-	9	-	s
$T_{\text{Power off}}$	The time holding the FULL_CARD_POWER_OFF# pin to low level for the module into power off status	-	3	-	s

NOTE

After powering off, please wait for 9 seconds at least, and the power on the module.

3.3 Reset Function

SIM8202E-M2 can be reset by driving the RESET# pin to a low level.

The RESET# signal has been internally pulled up to 1.8V, so it does not need pull up externally. The following figure shows the reference circuit of RESET# pin.

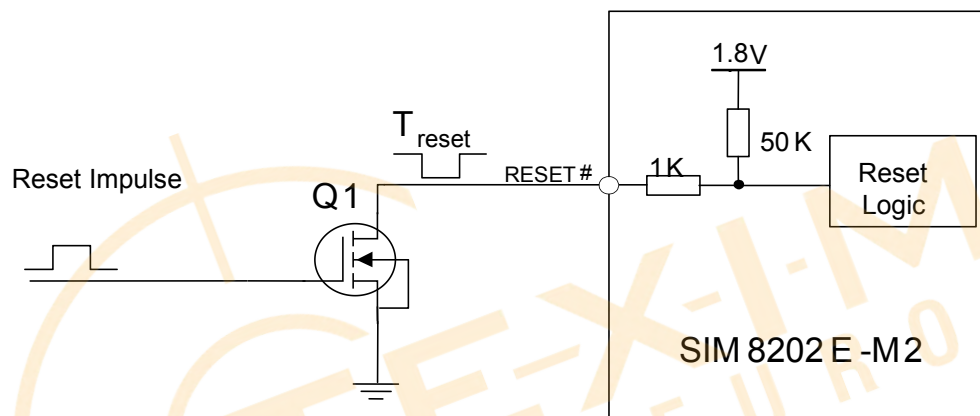

Figure 11: Reference reset circuit

Table 13: Definition of RESET# pin

Pin name	Pin no.	Electrical description	description	Comment
RESET#	67	DI,PU	System reset control input Active low	RESET# has been pulled up to 1.8V internally

The reset timing sequence of the module is shown in the following figure.

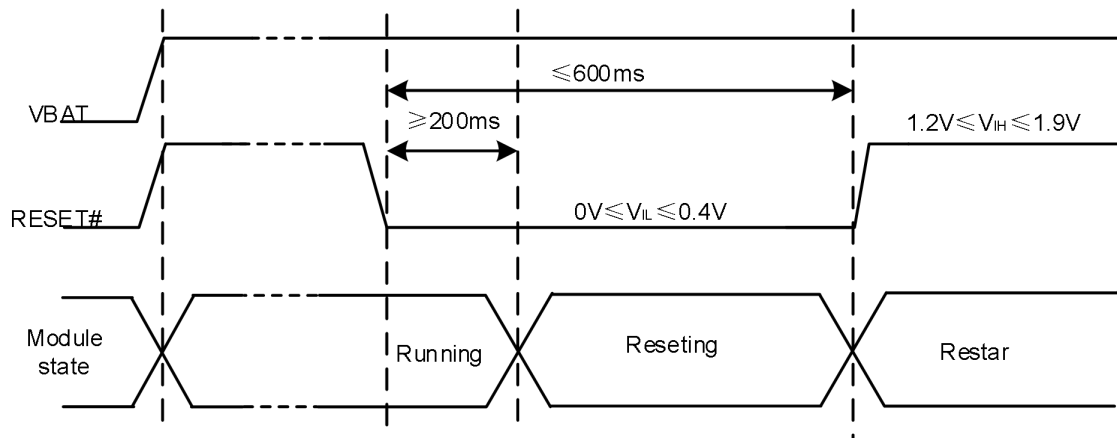

Figure 12: The reset timing sequence of the module

Table 14: RESET# pin electrical characteristics

Symbol	Description	Min.	Typ.	Max.	Unit
T_{reset}	Low level hold time on RESET# pin	200	-	600	ms
V_{IH}	Input high level voltage	1.2	-	1.9	V
V_{IL}	Input low level voltage	0	-	0.4	V

NOTE

Please ensure that there is no capacitance on RESET# pin.

3.4 I2C Interface

SIM8202E-M2 supports an I2C interface meet I2C specification version 5.0, with data rate up to 400kbps.

The following figure shows the I2C interface reference circuit.

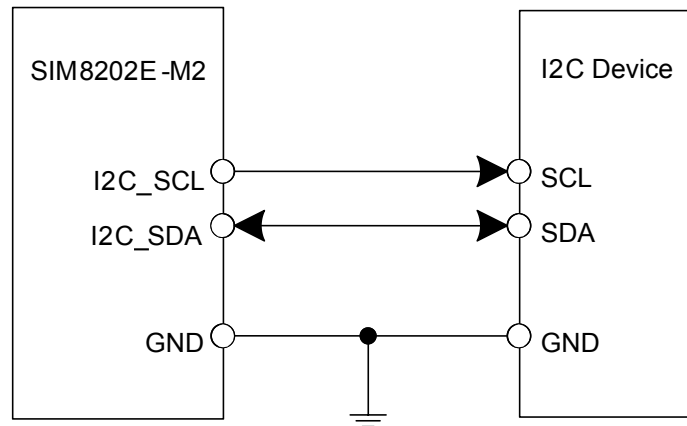

Figure 13: I2C reference circuit

Table 15: Definition of I2Cinterface

Pin name	Pin no.	Electrical description	Description	Comment
I2C_SDA	68	DIO	I2C data signal	1.8V voltage domain, internal pulled up to 1.8V. If unused, please keep open
I2C_SCL	38	DO	I2C clock signal	

3.5 WoWWAN#*

The WoWWAN# pin is a system wake-on signal which can be used as an interrupt signal for the host. Normally it keeps high level, and it will change to low level when certain conditions occur, such as receiving SMS, voice call (CSD, video) or URC reporting, the low level pulse time is 1 second.

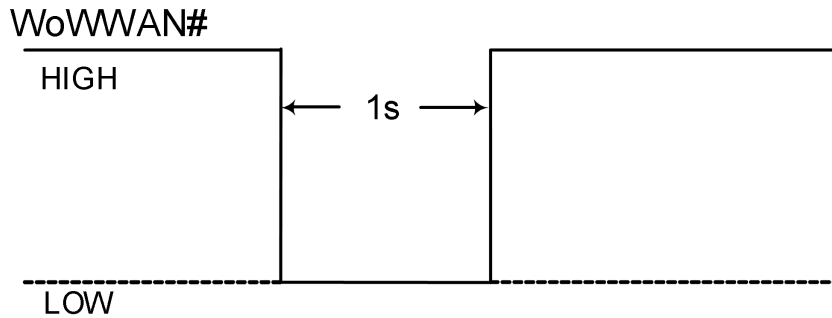

Figure 14: WoWWAN# signal level at SMS and URC report

The following figure shows the reference circuit of WoWWAN#.

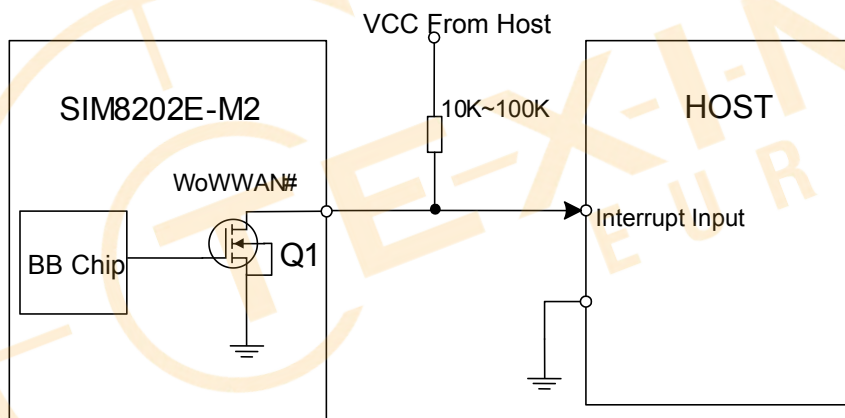

Figure 15: WoWWAN# reference circuit

Table 16: Definition of WoWWAN# pin

Pin name	Pin no.	Electrical description	Description	Comment
WoWWAN#	23	OD	Wake on the host Active low	

NOTE

“*” means under development.

3.6 USB Interface

SIM8202E-M2 supports one USB interface which complies with the USB3.1 and 2.0 specifications.

USB 3.1 data rate up to 10Gbps. Customers can choose USB3.1 or USB2.0 for their needs.

The USB interface is used for AT command communication, data transmission, GNSS NMEA output, firmware upgrade and software debugging.

The module supports USB suspend and resume mechanism which can save power consumption. If there is no data transmission on the USB bus, the module will enter suspend mode automatically.

The following figure is the USB reference circuit.

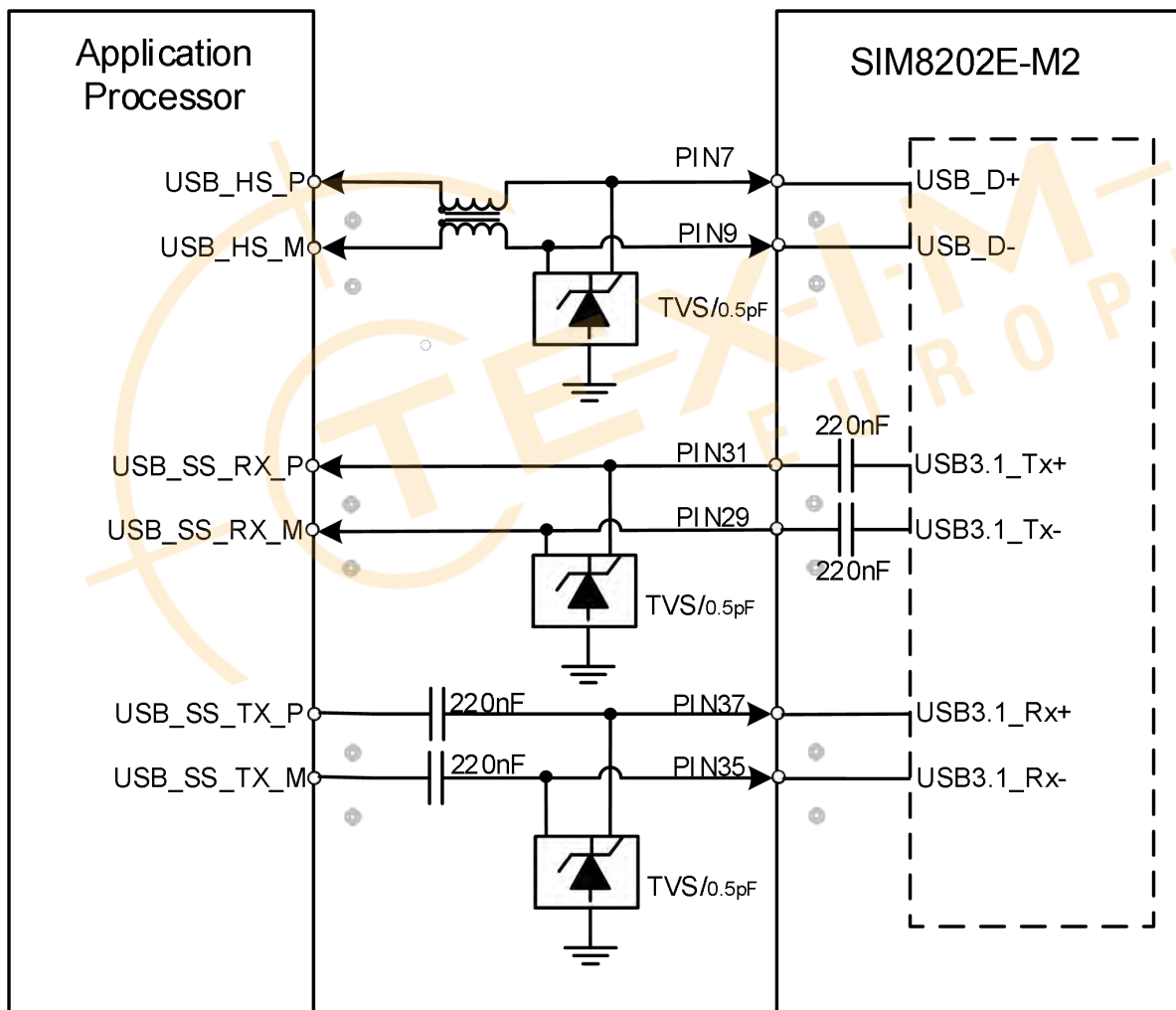

Figure 16: USB reference circuit

The following figure is the type-C USB reference circuit with CC detector.

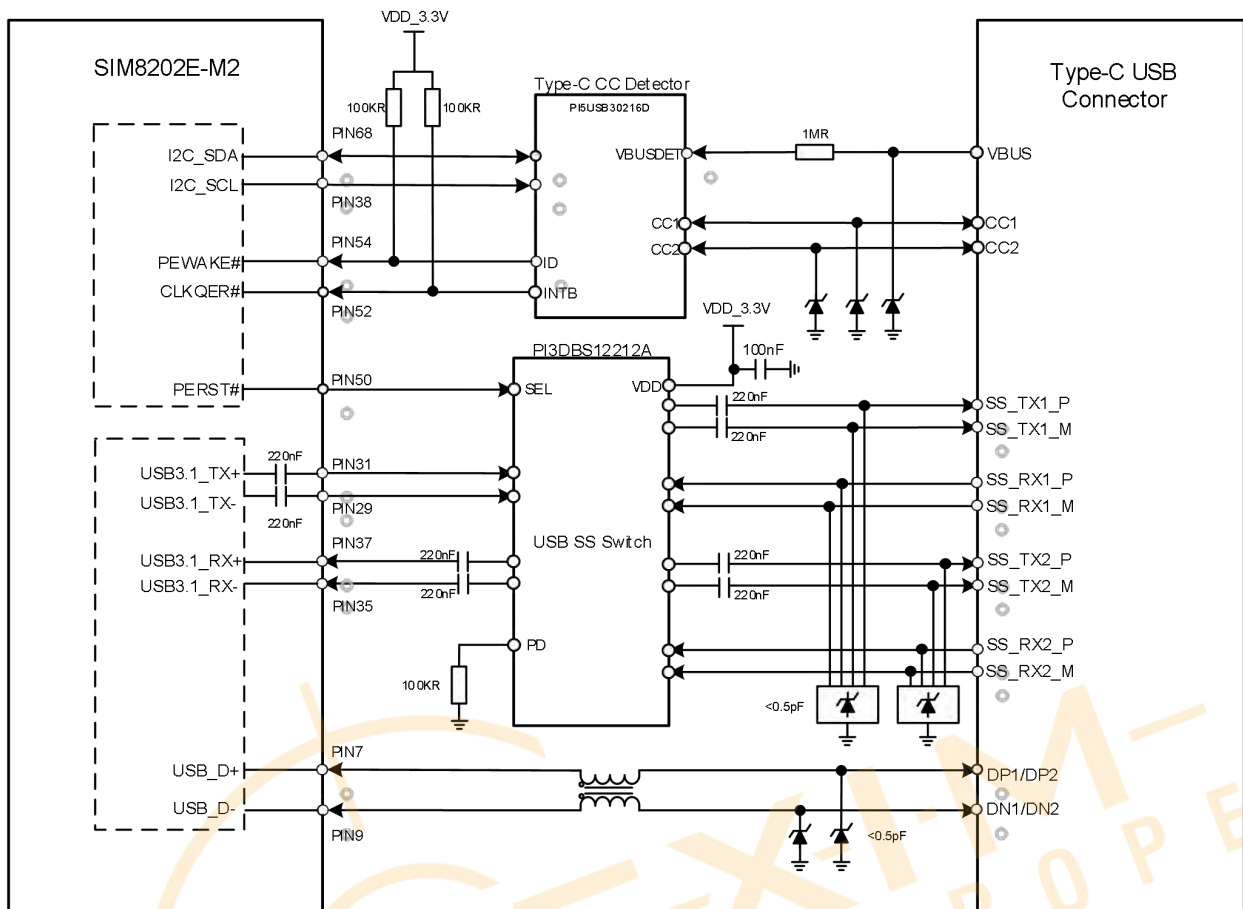

Figure 17: Type-C USB reference circuit with CC detector

Table 17: Definition of USB interface

Pin name	Pin no.	Electrical description	Description	Comment
USB_D+	7	AIO	Differential USB bi-directional data positive	
USB_D-	9	AIO	Differential USB bi-directional data negative	
USB3.1_Tx-	29	AO	USB3.1 transmit data negative	USB3.1 data rate up to 10Gbps
USB3.1_Tx+	31	AO	USB3.1 transmit data positive	USB2.0 data rate up to 480Mbps
USB3.1_Rx-	35	AI	USB3.1 receive data negative	
USB3.1_Rx+	37	AI	USB3.1 receive data positive	
PEWAKE#*	54	DI	For CC detector function	Need external pull up to 3.3V by 100kR resistor
CLKREQ#*	52	DI	For indicating change in I2C registers interrupt signal.	
PERST#*	50	DO	USB3.1 type-C switch control signal	

NOTE

1. “*”: PEWAKE#, CLKREQ#, PERST# be used for PCIe assistant control signal by default , if need configure type-C USB interface, recommend these three signal used for GPIO function.
2. If use PCIe interface already, PEWAKE#, CLKREQ#, PERST# signal of the module cannot use for GPIO control, but can use other unused GPIO ports configuration, for more details, please contact SIMCom support teams.

Table 18: USB interface recommended CC detector, USB3.1 type-C switch and TVS diode list

No.	Manufacturer	Part number	Package
1	WILL	ESD5302N-3/TR	DFN1006-3L
2	PERICOM	PI5USB30216D	QFN12
3	PERICOM	PI3DBS12212A	QFN3X3

USB HS D+/D- layout guidelines:

- Require differential trace impedance is $90\pm 10\% \Omega$.
- The intra-lane length mismatch of the differential signal lanes is less than 1mm.
- Gap from other signals keeps 3xline width.
- External components should be placed near the USB connector.
- Trace routes away from other sensitive signals (RF, audio, and 38.4M XO).
- The TVS diode should be placed close to the USB pins of M.2 connector.
- Maximum PCB trace length cannot exceed 100mm outside of module, the shorter trace and more better.

USB SS TX/RX layout guidelines:

- Require differential trace impedance is $90\pm 10\% \Omega$.
- The intra-lane length mismatch of the differential signal lanes is less than 500um.
- Gap from other signals keeps 4xline width.
- Gap between Rx-to-Tx keeps 4xline width.
- External components should be placed near the USB connector.
- Trace routes away from other sensitive signals (RF, especially 2.4 GHz).
- The TVS diode should be placed close to the USB pins of M.2 connector.
- Route differential pairs in the inner layers with a solid GND reference to have good impedance control and to minimize discontinuities.
- Keep isolation between the Tx pair, Rx pair, and DP/DM to avoid crosstalk.
- If core vias are used, use no more than two core vias per signal line to limit stubs.

3.7 PCIe Interface

SIM8202E-M2 supports PCIe Gen3 one lane interfaces, which data rate up to 8Gbps, and can be used as EP or RC* mode. CLKREQ# and PEWAKE# needs pull up to 3.3V by 100K resistor in customer's design. The following figure is the PCIe reference circuit.

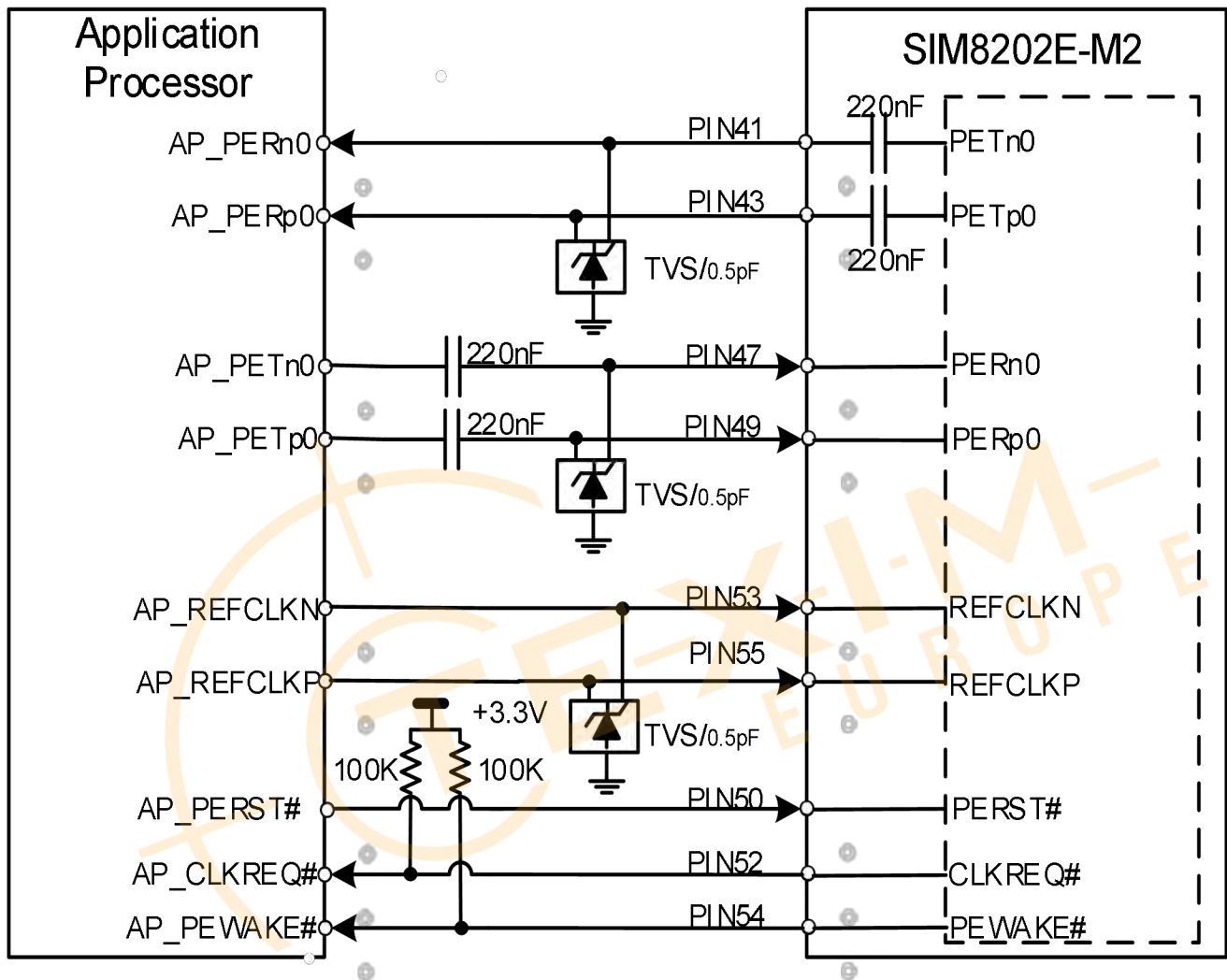

Figure 18: PCIe interface reference circuit (EP Mode)

NOTE

1. "*" means under development.
2. The AC capacitors of AP_PETn0 and AP_PETp0 should be closed to AP.
3. The voltage domain of PCIe assistant signals is 3.3V.
4. If the module use as EP module, the USB interface not support at the same time.

Table 19: Definition of PCIe interface

Pinname	Pin no.	Electrical description	Functional description	Comment
PETn0	41	AO	PCIe transmit data negative	
PETp0	43	AO	PCIe transmit data positive	
PERn0	47	AI	PCIe receive data negative	
PERp0	49	AI	PCIe receive data positive	
REFCLKN	53	AIO	PCIe reference clock negative	
REFCLKP	55	AIO	PCIe reference clock positive	
PERST#	50	DI	PERST# is a functional reset to the Add-In module active low	3.3V voltage domain, CLKREQ# and PEWAKE# required
CLKREQ#	52	DIO	PCIe reference clock request signal active low	pull up external, Default as EP mode.
PEWAKE#	54	DIO	PCIe wake up signal active low	If unused, please keep open

Table 20: PCIe interface recommended TVS diode list

No.	Manufacturer	Part number	Package
1	WILL	ESD5302N-3/TR	DFN1006-3L

PCIe interface layout guidelines:

- Require differential trace impedance is $90 \pm 10\% \Omega$.
- The intra-lane length mismatch of the differential signal lanes is less than 500um.
- Gap from other signals keeps 4xline width.
- Gap between Rx-to-Tx keeps 4xline width.
- Should be routed away from sensitive signals.
- The TVS diode should be placed close to the PCIe pins of M.2 connector.
- All other sensitive/high-speed signals and circuits must be protected from PCIe corruption.
- PCIe signals must be protected from noisy signals (clocks, SMPS).
- Each trace needs to be adjacent to a ground plane.
- Maximum PCB trace length cannot exceed 150mm outside of module, the shorter trace and more better.

3.8 (U)SIM Interface

SIM8202E-M2 supports two (U)SIM cards but single standby. The (U)SIM2 can use e-(U)SIM* card in the module or external (U)SIM card, the size is 2mm*2mm*1mm of the e-(U)SIM in the module. Both (U)SIM1 and (U)SIM2 are dual-voltage 1.8V or 3.0V.

NOTE

1. Customers choose the e-(U)SIM products according to the above size, SIMCom will provide the e-(U)SIM assemble into the module.

Table 21: (U)SIM electrical characteristics in 1.8V mode ((U)SIM_PWR=1.8V)

Symbol	Parameter	Min.	Typ.	Max.	Unit
(U)SIM_PWR	Power supply for (U)SIM card	1.65	1.8	1.95	V
V _{IH}	High-level input voltage	1.26	-	1.95	V
V _{IL}	Low-level input voltage	0	-	0.36	V
V _{OH}	High-level output voltage	1.44	-	1.8	V
V _{OL}	Low-level output voltage	0	-	0.4	V

Table 22: (U)SIM electrical characteristics in 3.0V mode ((U)SIM_PWR=3.0V)

Symbol	Parameter	Min.	Typ.	Max.	Unit
(U)SIM_PWR	Power supply for (U)SIM card	2.7	3.0	3.05	V
V _{IH}	High-level input voltage	2.1	-	3.05	V
V _{IL}	Low-level input voltage	0	0	0.6	V
V _{OH}	High-level output voltage	2.4	-	3.0	V
V _{OL}	Low-level output voltage	0	0	0.4	V

The module supports (U)SIM card hot-swap by the (U)SIM_DET pin, which is a level trigger pin. The (U)SIM_DET pin pulled up internally.

The following figure shows the reference circuit of (U)SIM card.

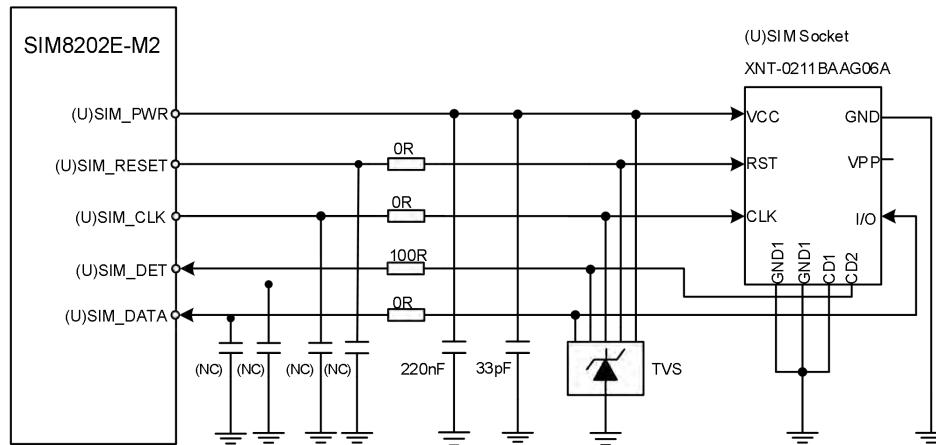

Figure 19: (U)SIM interface reference circuit

When the (U)SIM card is inserted, the (U)SIM_DET will change from high to low level. The falling edge will indicate insertion of the (U)SIM card. When the (U)SIM card is removed, the (U)SIM_DET will change from low to high level. This rising edge will indicate unplug the (U)SIM card.

Using “AT+UIMHOTSWAPON=0 or 1” and “AT+UIMHOTSWAPLEVEL=0 or 1” AT command to set module SIM card hot swap function enable and SIM card detection level, for more details, please refer to SIM8200 Series_AT Command Manual document.

Using “AT+SMSIMCFG=1,1” and “AT+SMSIMCFG=1,2” AT command to switch (U)SIM1 and (U)SIM2 function, for more details, please refer to SIM8200 Series_AT Command Manual document.

Table 23: Definition of (U)SIM interface

Pin name	Pin no.	Electrical description	Description	Comment
(U)SIM1_PWR	36	PO	Power supply for (U)SIM1 card	
(U)SIM 1_DATA	34	DIO	(U)SIM1 card data, which has been pulled up to (U)SIM1_VDD via a 20KR resistor internally	
(U)SIM 1_CLK	32	DO	(U)SIM1 clock signal	
(U)SIM1_RESET	30	DO	(U)SIM1 Reset control	
(U)SIM 1_DET	66	DI	(U)SIM1 card detect, which has been pulled up to VDD_P3 via a 470KR resistor internally	
(U)SIM2_PWR	48	PO	Power supply for (U)SIM2 card	
(U)SIM2_DATA	42	DIO	(U)SIM2 card data, which has been pulled up to (U)SIM2_VDD via a 20KR resistor internally	
(U)SIM2_CLK	44	DO	(U)SIM2 clock signal	
(U)SIM2_RESET	46	DO	(U)SIM2 Reset control	
(U)SIM2_DET	40	DI	(U)SIM2 card detect, which has been pulled up to VDD_P3 via a 470KR resistor internally	

1.8/3.0V voltage domain, all (U)SIM interfaces should be protected against ESD. If unused, please keep open

The following table shows recommended TVS of ESD protect and (U)SIM socket.

Table 24: Recommended TVS and (U)SIM socket list

Name	Manufacturer	Part number
TVS	ST	ESDA6V1-5W6
(U)SIM socket	Suntech	XNT-0211BAAG06A

If the (U)SIM card hot-swap function is not used, customers can keep the (U)SIM_DET pin open.

The (U)SIM card layout guidelines:

- Make sure that the (U)SIM card holder should be far away from the antenna while in PCB layout.
- (U)SIM traces should keep away from RF lines, VBAT and high-speed signal lines.
- The traces should be as short as possible.
- Keep (U)SIM holder's GND connect to main ground directly.
- Shielding the (U)SIM card signal by ground.
- Recommended to place a 33pF ~ 1uF capacitor on (U)SIM_PWR line and keep close to the holder.
- The rise/fall time of (U)SIM_CLK should not be more than 40ns.
- The parasitic capacitance of TVS should not exceed 60pF and the TVS should be placed close to the (U)SIM socket.

3.9 I2S Interface

SIM8202E-M2 supports one I2S interface for external codec, which follows the requirements in the Phillips I2S bus specification.

Table 25: I2S format

Characteristics	Specification
Line interface format	Linear (Fixed)
Data length	16bits (Fixed)
I2S clock/sync source	Master mode (Fixed)
I2S clock frequency	1.536MHz (Default)
I2S MCLK frequency	12.288MHz (Default)
Data ordering	MSB

NOTE

For the details about I2S AT commands, please refer to [document \[1\]](#) in the appendix.

3.9.1 I2S Timing

The module supports I2S sampling rate of 48 KHz and 32 bit coding signal (16 bit length), the timing sequence is shown in the following figure.

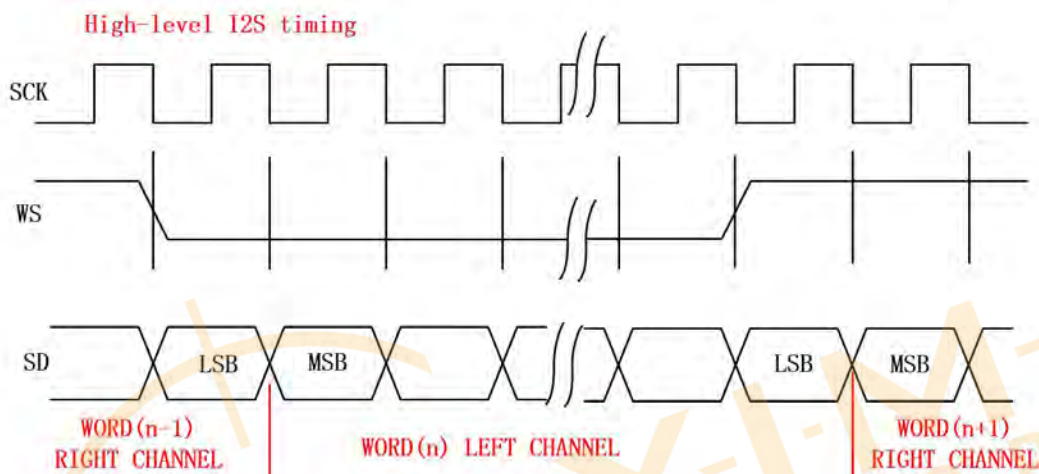

Figure 20: I2S timing

Table 26: I2S timing parameters

Signal	Parameter	Description	Min.	Typ.	Max.	Unit
I2S_MCLK	Frequency	Working frequency	–	12.288	12.288	MHz
	T	Clock period	81.380	81.380	–	ns
	t(HC)	Clock high	0.45T	–	0.55T	ns
	t(LC)	Clock low	0.45T	–	0.55T	ns
I2S_CLK	Frequency	Working frequency	8	48	48	KHz
	T	Clock period	20.83	20.83	125	us
	t(HC)	Clock high	0.45T	–	0.55T	ns
	t(LC)	Clock low	0.45T	–	0.55T	ns
I2S_WA	t(sr)	DIN/DOUT and WA input setup time	16.276	–	–	ns
	t(hr)	DIN/DOUT and WA input hold time	0	–	–	ns
	t(dtr)	DIN/DOUT and WA output delay	–	–	65.10	ns

t(htr)	DIN/DOUT and WA output hold time	0	-	-	ns
--------	----------------------------------	---	---	---	----

3.9.2 I2S Reference Circuit

The following figure is the external codec reference design circuit.

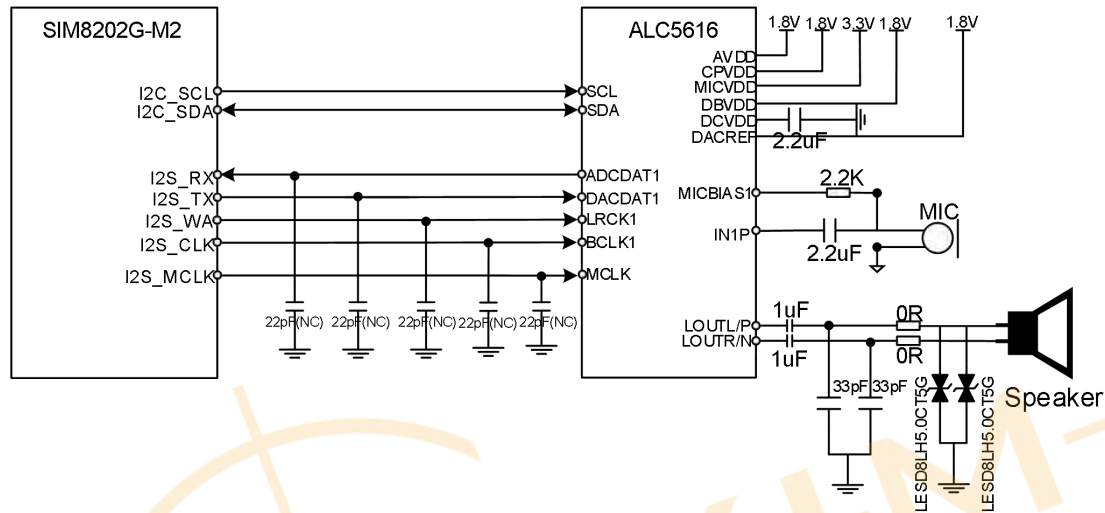

Figure 21: Audio codec diagram circuit

Table 27: Definition of I2S interface

Pin name	Pin no.	Electrical description	Description	Comment
I2S_CLK	20	DO	I2S clock output	1.8V voltage domain, also can be used as PCM interface, If unused, please keep open
I2S_RX	22	DI	I2S data input	
I2S_TX	24	DO	I2S data output	
I2S_WA	28	DO	I2S word alignment select (L/R)	
I2S_MCLK	60	DO	I2S master clock	

The PCM interface is multiplexing with I2S interface. The default audio interface of the module is I2S.

Table 28: The PCM interface is multiplexing with I2S interface

Pin name	PCM interface
I2S_RX	PCM_DIN
I2S_TX	PCM_OUT
I2S_WA	PCM_SYNC
I2S_CLK	PCM_CLK

I2S_MCLK

-

Audio layout guidelines:

Analog input

- 0.2mm trace widths; 0.2mm spacing between other signals trace.
- Pseudo differential route for MIC.
- Isolate from noise sources, such as antenna, RF signals, SMPS, clocks, and other high speed signals.

Analog output

- Isolate from noise sources such as antenna, RF signals, SMPS, clocks, and other high speed signals.
- Speaker output signal – route as differential pair with 0.5mm trace widths.

Audio power and GND

- Recommend add magnetic bead on AVDD net reserved for debug.
- VDD cannot directly use VBAT as the power supply.
- AGND need add GND via to the main GND plane directly.



3.10 DPR*

DPR (Dynamic Power Reduction) signal is used for SAR (Specific Absorption Rate) requirements. The RF output power would reduce if this signal is triggered by sensor under some certain conditions, such as SAR sensor triggered, defined by customers.

User can activate this function with AT command.

Table 29: Definition of DPR# pin

Pin no.	Pin name	Pin status	Function
25	DPR	Low	Max transmitting power will be reduced by set through AT command
		High	Max transmitting power will not be reduced (default)
		Floating	Max transmitting power will not be reduced

NOTE

“*” means under development.



3.11 CONFIG Pins

These signals are provided to indicate its specific configuration that is WWAN-USB3.1 of SIM8202E-M2.

Table 30: CONFIG pins state of the module

Pin no.	Pin name	Description
21	CONFIG_0	Connected to ground internally
69	CONFIG_1	Connected to ground internally
75	CONFIG_2	Connected to ground internally
1	CONFIG_3	Not connected

In the M.2 specifications, the CONFIG pins are defined as below.

Table 31: CONFIG interface definition

CONFIG_0 (Pin 21)	CONFIG_1 (Pin 69)	CONFIG_2 (Pin 75)	CONFIG_3 (Pin 1)	Module type and main host interface	Comments
GND	GND	GND	NC	WWAN – USB 3.1	Vendor defined

3.12 LED1#

LED1# is open drain output and is used to allow SIM8202E-M2 to provide network status via LED which will be provided by the host.

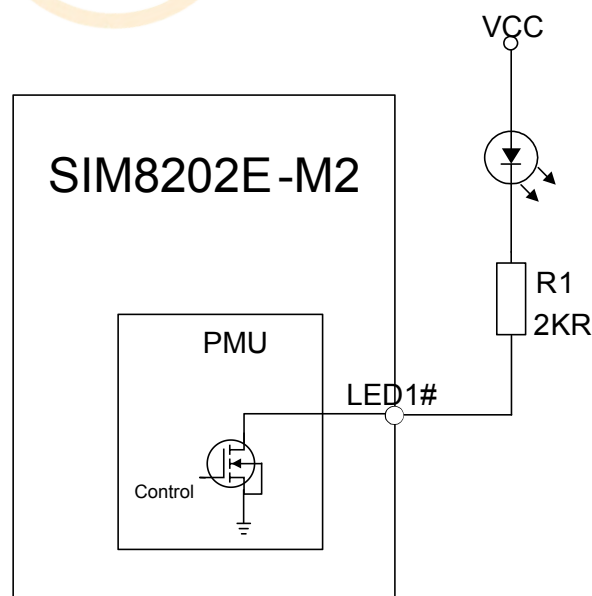

Figure 22: LED1# reference circuit

Table 32: Definition of LED1# pin

Pin name	Pin no.	Electrical description	Description	Comments
LED1#	10	OD	The module status indicator via LED devices Active low	

NOTE

1. The value of the resistor R1 depends on the LED characteristics. The recommend value of R1 is 2KR.

The timing parameter is shown in the following table.

Table 33: LED1# pin status

LED1# pin status	Module status
Always On	Searching network; call connection(including5G,VOLTE)
100ms ON, 100ms OFF	Data transmit; 5G registered network
200ms ON, 200ms OFF	Data transmit; 4G registered network
800ms ON, 800ms OFF	Data transmit;3G registered network
OFF	Power off ;Sleep mode

3.13 W_DISABLE1#

The W_DISABLE1# pin controls SIM8202E-M2 to enter the flight mode. When the W_DISABLE1# signal is pulled to low level, RF function would be disabled. Otherwise the RF function would be active.

The following figure shows the reference circuit of W_DISABLE1#.

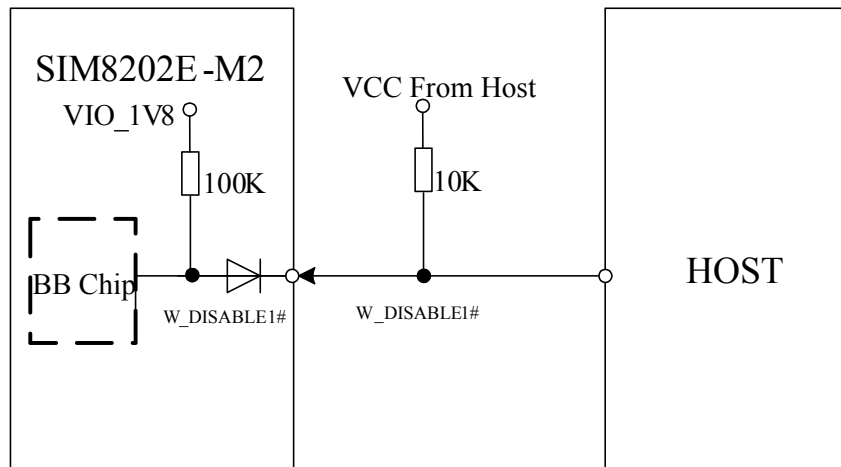

Figure 23: W_DISABLE1# pin reference circuit

Table 34: Definition of W_DISABLE1# pin

Pin name	Pin no.	Electrical description	Description	Comments
W_DISABLE1#	8	DI	WWAN RF disable Active low	3.3V tolerant but can be driven by either 1.8V or 3.3V GPIO

Table 35: W_DISABLE1#pin status

W_DISABLE1# pin status	Module operation
Input low level	Flight mode: RF is disabled
Input high level	AT+CFUN=4: Flight mode AT+CFUN=1: RF is enabled (default)

3.14 TDD_SYNC_PPS*

In SIM8202E-M2 design, W_DISABLE2# and TDD_SYNC_PPS function can compatible PIN26 of SIM8202E-M2. SIM8202E-M2 hardware support TDD_SYNC_PPS function by default.

When PIN26 configure as TDD_SYNC_PPS function, it can generate pulse use for indication NSA and SA sub6 the beginning frame flag of DL-UL, the pin level is 1.8V.

Recommended reference circuit is shown in the following figure.

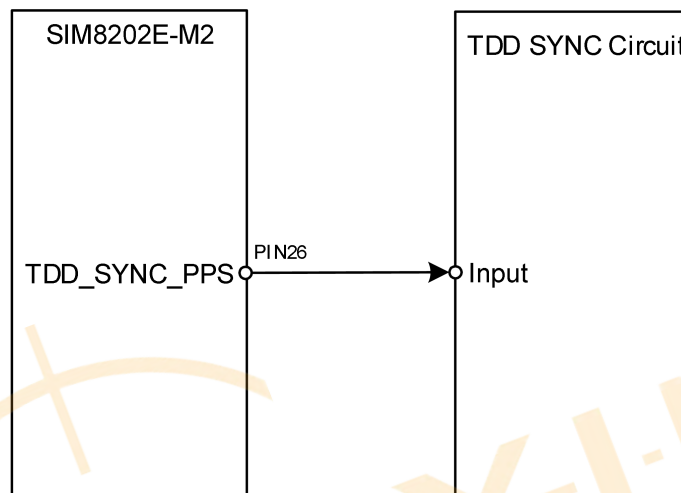

Figure 24: TDD_SYNC_PPS pin reference circuit

Table 36: Definition of TDD_SYNC_PPS pin

Pin name	Pin no.	Electrical description	Description	Comments
TDD_SYNC_PPS	26	DO	It can generate pulse use for indication NSA and SA sub6 the beginning frame flag of DL-UL	1.8V voltage domain

NOTE

1. "*" means under development.
2. The TDD_SYNC_PPS pin also can be configured GPS_1PPS signal output by software, the TDD_SYNC_PPS and GPS_1PPS function can't be used at the same time.
3. About TDD_SYNC_PPS and GPS_1PPS function more detail, please contact SIMCom support teams.

The following is TDD_SYNC_PPS signal design guidelines:

- This signal trace should be treated as a data transmission line, required impedance is 50 Ω .
- This signal trace should as short as possible and cannot exceed 40mm out of the module.
- This signal trace should far away from RF, power and high-speed signals.
- This signal trace should be protected completely by GND.
- The rising slew rate is no poor than 3ns, falling slew rate is no poor than 5ns, even with default lowest drive strength (2mA) being selected.



3.15 W_DISABLE2#

In SIM8202E-M2 design, W_DISABLE2# and TDD_SYNC_PPS function can compatible PIN26 of SIM8202E-M2. SIM8202E-M2 hardware support TDD_SYNC_PPS function by default.

The W_DISABLE2# pin controls SIM8202E-M2 to disable the GNSS function. When the W_DISABLE2# signal is pulled to low level, the GNSS function would be disabled. The following figure shows the reference circuit of W_DISABLE2#.

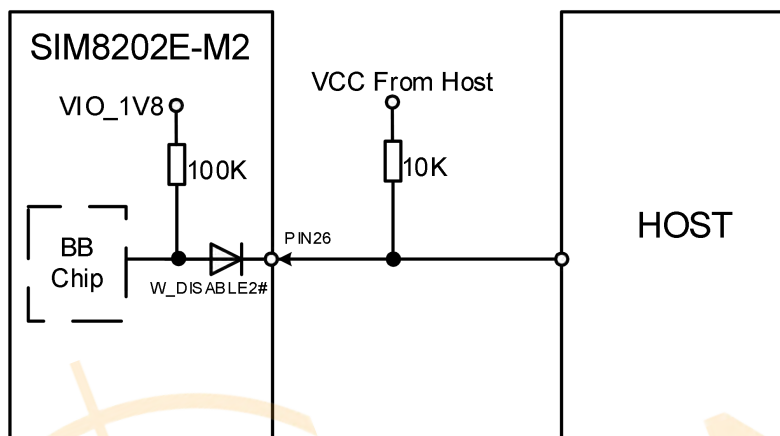

Figure 25: W_DISABLE2#pin reference circuit

Table 37: Definition of W_DISABLE2# pin

Pin name	Pin no.	Electrical description	Description	Comments
W_DISABLE2#	26	DI	GNSS disable Active low	3.3V tolerant but can be driven by either 1.8V or 3.3V GPIO

Table 38: W_DISABLE2# pin status

W_DISABLE2# pin status	Module operation
Input Low Level	GNSS function is disabled
Input High Level	AT+CGPS=0: GNSS function is disabled AT+CGPS=1: GNSS function is enabled(default)

3.16 Antenna Control Interface*

ANTCTL[0:3] and RFFE signals are used for tunable antenna control and should be routed to an appropriate antenna control circuitry.

The following table is the definitions for antenna control interfaces.

Table 39: Definition of antenna control interface through GPIOs

Pin name	Pin no.	Electrical description	Description	Comments
ANTCTL0	59	DO	Antenna tuner control0	
ANTCTL1	61	DO	Antenna tuner control1	1.8V voltage domain. If unused, please keep open
ANTCTL 2 (RFFE_SDATA) ²	58	DO (DIO)	Antenna tuner control2 (Antenna tuner MIPI DATA) ²	
ANTCTL3 (RFFE_SCLK) ²	56	DO	Antenna tuner control3 (Antenna tuner MIPI CLK) ²	

NOTE

1. "*" means under development, for details please contact SIMCom support teams.
2. The RFFE signals are multiplexed with ANTCTL2 and ANTCTL3.

3.17 UART Interface

SIM8202E-M2 hardware configure as normal communication UART (AT command) by default. If need coexistence signal function, please contact SIMCom support teams.

Table 40: Definition of UART interface

Pin name	Pin no.	Electrical description	Description	Comments
COEX1* (COEX_TX*)	64	DO	SIM8202E-M2 hardware configures as normal communication UART(AT command) by default	If need coexistence signal function, please contact SIMCom support teams
COEX2* (COEX_RX*)	62	DI		

The UART level of SIM8202E-M2 is 1.8V, if need communication with 3.3V serial port level , it recommended to use level shift IC. The following figure shows the reference design circuit of level shift.

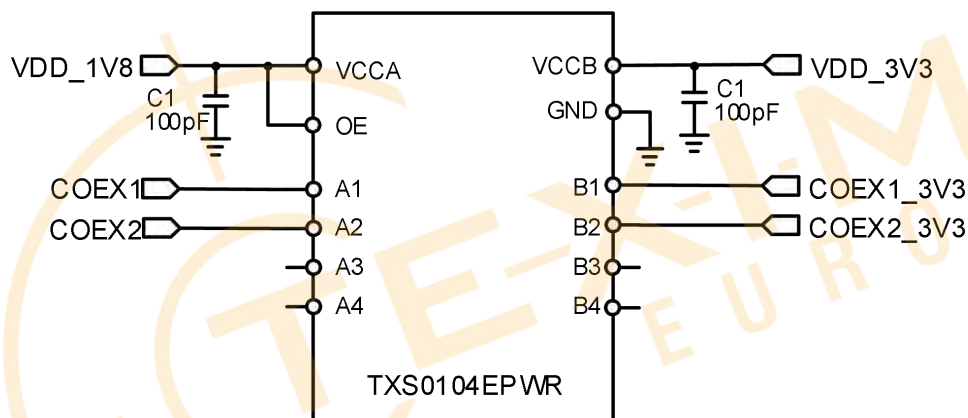

Figure 26: UART level conversion circuit

3.18 GPIOs Interface

There pins can be configured as GPIO function of SIM8202E-M2 in following table, and it configuration by software configure according to the customer's requirements.

Table 41: GPIO list

SIM8202E-M2	Pin no.	Interrupt function	Pull (default options)
COEX1	64		B-PD: nppukp
COEX2	62	Y	B-PD: nppukp
I2S_WA	28	Y	B-PD: nppukp
I2S_RX	22	Y	B-PD: nppukp
I2S_TX	24	Y	B-PD: nppukp
I2S_CLK	20	Y	B-PD: nppukp
DPR	25	Y	B-PD: nppukp
I2C_SDA(IO)	68	Y	B-PD: nppukp
I2C_SCL(IO)	38	Y	B-PD: nppukp
TDD_SYNC_PPS*	26	Y	B-PD: nppukp
I2S_MCLK(IO)	60		B-PD: nppukp

NOTE

1. "*" means under development, about TDD_SYNC_PPS function more detail, please contact SIMCom support teams.
2. I2C_SDA and I2C_SCL signal of the module pulled up to 1.8V already.

4 Antenna Interfaces

SIM8202E-M2 provides four antenna interfaces, and all of them should be 50Ω impedance controlled for RF signal.

4.1 Antenna Definitions

For detailed designs about antenna and if there is a requirement for minimum antennas, please refer to the antenna design guide “SIM8202E-M2 Antenna Port Mapping and Design Guide”.

Antenna interfaces are shown in the following figure.



Figure 27: Antenna interfaces

Table 42: Antenna port definitions

ANT item	ANT function	Frequency range	Functional description
ANT0	3G/4G/5G LB/MHB TRX 5G n41 DL-MIMO1 5G n77/n78/n79 DIV	617MHz~2690MHz 2496MHz~2690MHz 3300MHz~5000MHz	3G/4G/5G signal send and receive
ANT1	3G/4G/5G MHB DIV 5G n41 DL-MIMO2	1710MHz~2690MHz 3400MHz~3700MHz	3G/4G/5G signal send and receive

	5G n77/n78/n79 DL-MIMO2	3300MHz~5000MHz	
ANT2	3G/4G/5G MHB DL-MIMO2	1710MHz~2690MHz	3G/4G/5G/GNSS signal receive
	5G n41 DIV	2496MHz~2690MHz	
	5G n77/n78/n79 DL-MIMO1	3300MHz~5000MHz	
	GNSS	1166MHz~1610MHz	
ANT3	3G/4G/5G LB DIV	617MHz~2690MHz	3G/4G/5G signal send and receive
	LB/MHB TX1		
	4G UHB TRX	3400MHz~3700MHz	
	3G/4G/5G MHB DL-MIMO1		
	5G N41 TRX	2496MHz~2690MHz	
	5G n77/n78/n79 TRX	3300MHz~5000MHz	

Table 43: SIM8202E-M2 frequency band and antenna ports mapping

ANTENNAS			ANT0	ANT1	ANT2	ANT3
BANDS						
FUNCTIONS						
3G/4G/5G	LB/MHB	TRX				
5G	n41	DL-MIMO1	✓			
5G	n77/n78/n79	DIV				
3G/4G/5G	MHB	DIV				
5G	N41	DL-MIMO2		✓		
5G	n77/n78/n79	DL-MIMO2				
3G/4G/5G	MHB	DL-MIMO2				
5G	n41	DIV			✓	
5G	n77/n78/n79	DL-MIMO1				
GNSS						
3G/4G/5G	LB	DIV				
4G	LB/MHB	TX1				
4G	UHB	TRX				✓
4G	MHB	DL-MIMO1				
5G	N41	TRX				
5G	n77/n78/n79	TRX				

NOTE

1. For basic function, only the antennas responding to TRX are needed.

4.1.1 3G/4G/5G Operating Frequency

Table 44: The module operating frequency

Frequency	Uplink (UL)	Downlink (DL)	Duplex
-----------	-------------	---------------	--------

bands			Mode
WCDMA B1	1920 ~ 1980MHz	2110 ~ 2170MHz	FDD
WCDMA B3	1710 ~ 1785MHz	1805 ~ 1880MHz	FDD
WCDMA B5	824 ~ 849MHz	869 ~ 894MHz	FDD
WCDMA B8	880 ~ 915MHz	925 ~ 960MHz	FDD
LTE B1	1920 ~ 1980MHz	2110 ~ 2170MHz	FDD
LTE B3	1710 ~ 1785 MHz	1805 ~ 1880MHz	FDD
LTE B5	824 ~ 849 MHz	869 ~ 894MHz	FDD
LTE B7	2500 ~ 2570MHz	2620 ~ 2690MHz	FDD
LTE B8	880 ~ 915MHz	925 ~ 960MHz	FDD
LTE B12	699 ~ 716MHz	729 ~ 746MHz	FDD
LTE B13	777 ~ 787MHz	746 ~ 756MHz	FDD
LTE B14	788 ~ 798MHz	758 ~ 768MHz	FDD
LTE B17	704 ~ 716MHz	734 ~ 746MHz	FDD
LTE B18	815 ~ 830MHz	860 ~ 875MHz	FDD
LTE B19	830 ~ 845MHz	875 ~ 890MHz	FDD
LTE B20	832 ~ 862MHz	791 ~ 821MHz	FDD
LTE B26	814 ~ 849MHz	859 ~ 894MHz	FDD
LTE B28	703 ~ 748MHz	758 ~ 803MHz	FDD
LTE B29 ¹	/	717 ~ 728MHz	SDL
LTE B34	2010 ~ 2025MHz	2010 ~ 2025MHz	TDD
LTE B38	2570 ~ 2620MHz	2570 ~ 2620MHz	TDD
LTE B39	1880 ~ 1920MHz	1880 ~ 1920MHz	TDD
LTE B40	2300 ~ 2400MHz	2300 ~ 2400MHz	TDD
LTE B41	2496 ~ 2690MHz	2496 ~ 2690MHz	TDD
LTE B42	3400 ~ 3600MHz	3400 ~ 3600MHz	TDD
LTE B43	3600 ~ 3800MHz	3600 ~ 3800MHz	TDD
LTE B48	3550 ~ 3700MHz	3550 ~ 3700MHz	TDD
LTE B71	663 ~ 698MHz	617 ~ 652MHz	FDD
5G n1	1920 ~ 1980MHz	2110 ~ 2170MHz	FDD
5G n3	1710 ~ 1785MHz	1805 ~ 1880MHz	FDD
5G n5	824 ~ 849MHz	869 ~ 894MHz	FDD
5G n7	2500 ~ 2570MHz	2620 ~ 2690MHz	FDD
5G n8	880 ~ 915MHz	925 ~ 960MHz	FDD
5G n12	699 ~ 716MHz	729 ~ 746MHz	FDD
5G n20	832 ~ 862MHz	791 ~ 821MHz	FDD
5G n28	703 ~ 748MHz	758 ~ 803MHz	FDD
5G n38	2570 ~ 2620MHz	2570 ~ 2620MHz	TDD
5G n40	2300 ~ 2400MHz	2300 ~ 2400MHz	TDD
5G n41	2496 ~ 2690MHz	2496 ~ 2690MHz	TDD
5G n48	3550 ~ 3700MHz	3550 ~ 3700MHz	TDD

5G n71	663 ~ 698MHz	617 ~ 652MHz	FDD
5G n77	3300 ~ 4200MHz	3300 ~ 4200MHz	TDD
5G n78	3300 ~ 3800MHz	3300 ~ 3800MHz	TDD
5G n79	4400 ~ 5000MHz	4400 ~ 5000MHz	TDD

NOTE

1. LTE-FDD B29 supports Rx only for secondary component carrier.

4.1.2 GNSS Frequency

The following table shows frequency specifications of GNSS antenna interface.

Table 45: GNSS frequency

Type	Frequency
GPS L1/Galileo/QZSS	1575.42±1.023MHz
GPS L5	1176.45±10.23MHz
GLONASS	1597.5~1605.8MHz
BeiDou/Compass	1561.098±2.046MHz

4.2 Antenna Installation

4.2.1 Antenna Requirements

The following table shows the requirements on 3G/4G/5G antennas and GNSS antenna.

Table 46: 3G/4G/5G/GNSS antennas

Parameter	Requirement
Operating Frequency	See Table 42 for each antenna
Direction	Omni Directional
Gain	> -3dBi (Avg)
Impedance	50 Ω
Efficiency	>50 %
Max. Input Power	50W
VSWR	< 2
Isolation	20dB is preferred

Cable Insertion Loss<1GHz	<1dB
Cable Insertion Loss 1GHz~2.2GHz	<1.5dB
Cable Insertion Loss 2.3GHz~2.7GHz	<2dB
Cable Insertion Loss3.3GHz~6GHz	<2.5dB

Table 47: GNSS antenna (for dedicated GNSS antenna only)*

Parameter	Requirement
Operating Frequency	L1: 1559~1609MHZ L5: 1166~1187MHz
Direction	Hemisphere, face to sky
Antenna Gain	>2 dB _{ic}
Impedance	50 Ω
Efficiency	>50 %
Max. Input Power	50W
VSWR	< 2
Polarization	RHCP or Linear
Noise Figure for Active Antenna	<1.5
Total Gain for Active Antenna	<17 dB
Cable Insertion Loss	<1.5dB

NOTE

“*” means these recommendations are for dedicated GNSS antenna which the application need best of class GNSS tracking performance.

4.2.2 Antenna Tuner

When end device need to support 700MHz low frequency (B12\B13\B28), it is recommended to add antenna tuner to improve RF performance. Antenna tuner contains antenna aperture tuner, antenna impedance tuner and hybrid tuner of the two. Aperture tuner optimizes the total antenna efficiency from the free space of the antenna terminal, and can optimize antenna efficiency across multiple frequency bands. Impedance tuner adjusts the mismatch between the RF front end and the antenna to achieve maximum transmission power. Hybrid tuner combines the advantages of both to maximize antenna RF performance. Customers can choose according to specific needs, according to the recommendations from the antenna vendor.

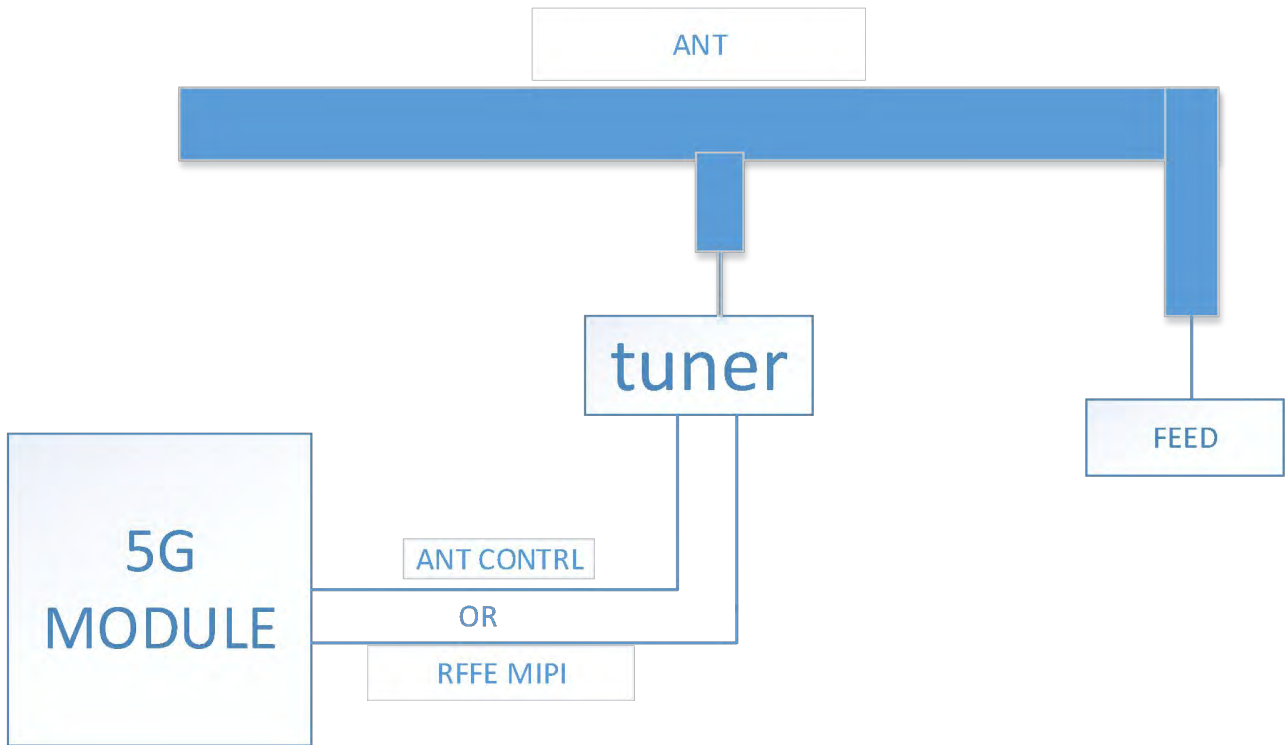

Figure 28: Aperture tuner reference block diagram

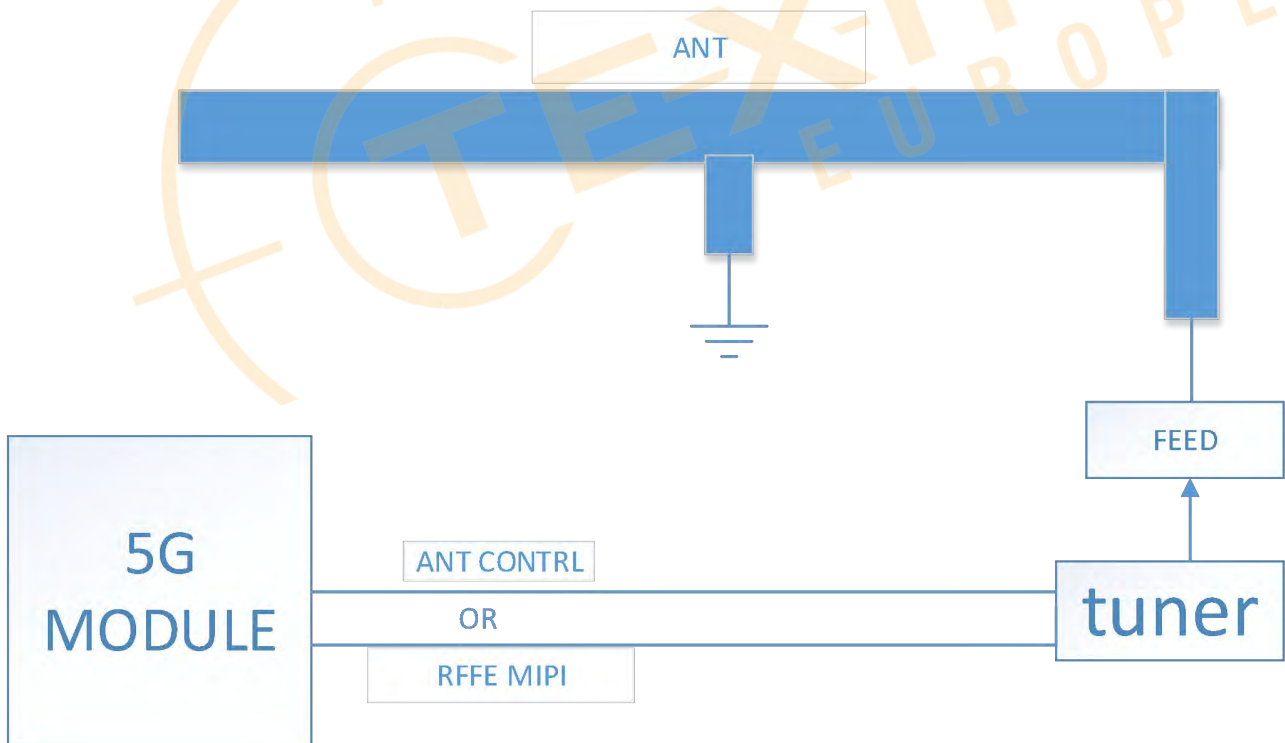

Figure 29: Impedance tuner reference block diagram

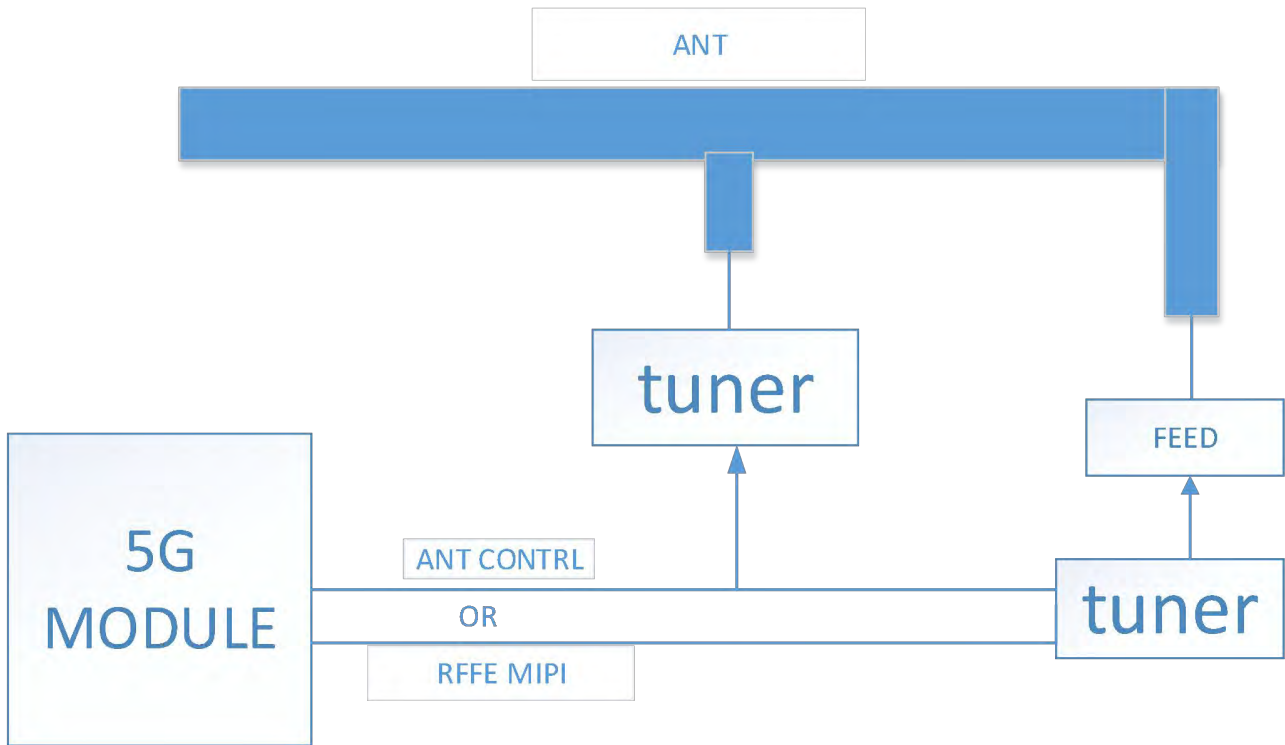

Figure 30: Hybrid tuner reference block diagram

The antenna control Tuner mipi interface of different package modules is as follows.

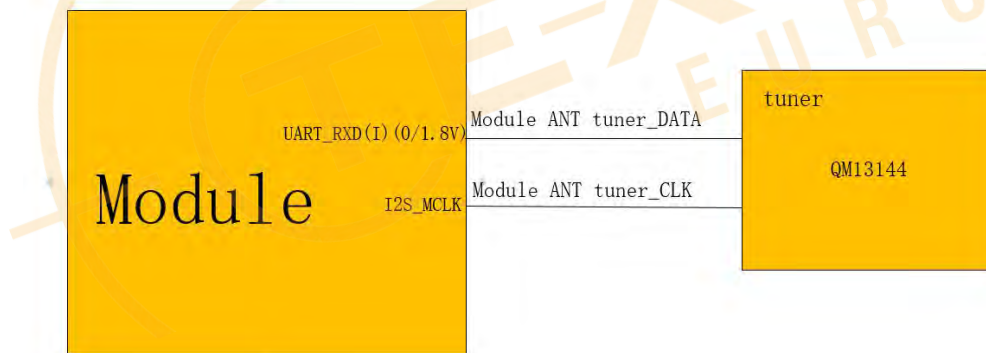

Figure 31: M.2 package Tuner mipi interface

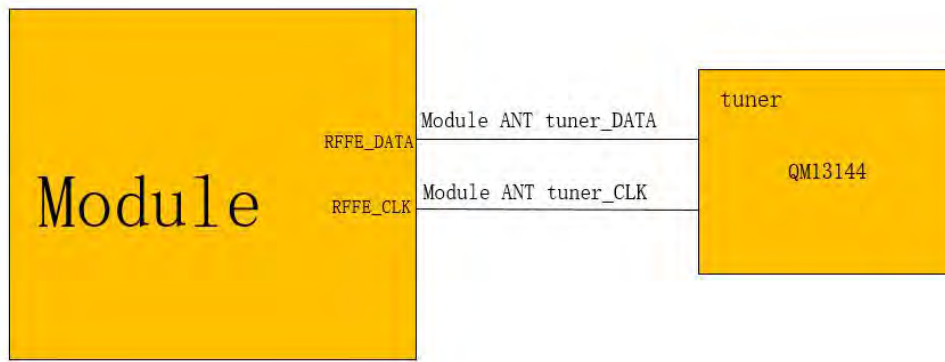

Figure 32: LGA package Tuner mipi interface

NOTE

When multiple Tuners are needed, pay attention to the distinction of the same device USID under the same group of mipi.
For details please refer to the Antenna Tuner Reference Design document and contact SIMCom support teams.

4.2.3 RF Plug Recommendation

SIM8202E-M2 is mounted with I-PEX's receptacle RF connectors 20449-001E-03, which size is 2.0mm*2.0mm*0.6mm. The connector dimensions are shown as below.

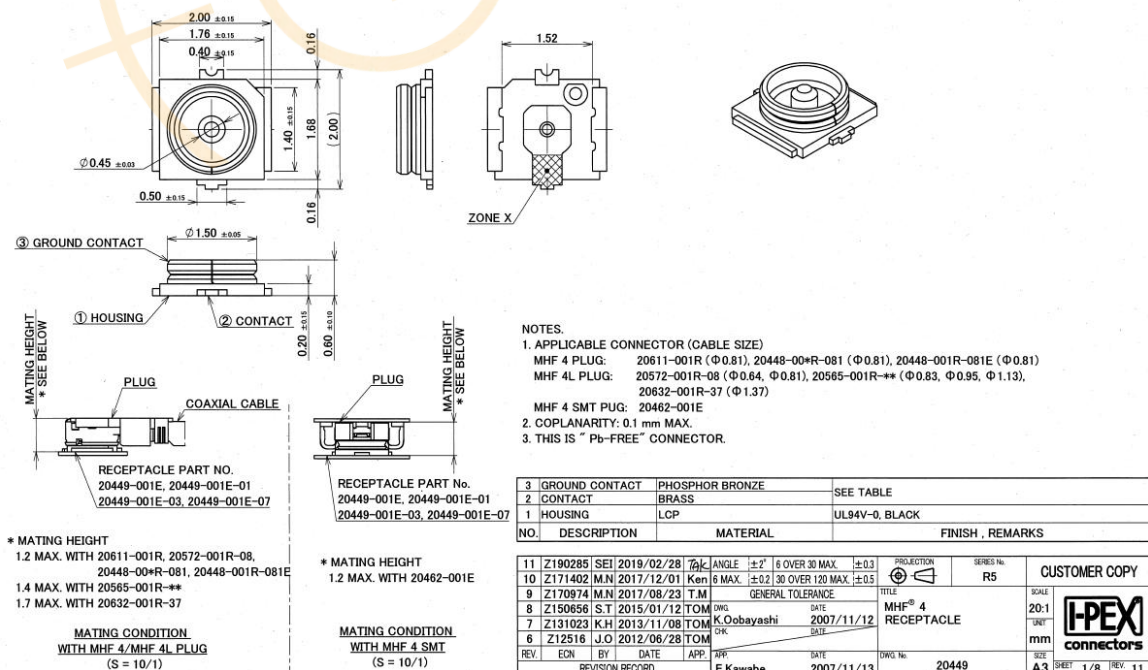

Figure 33:3D view of 20449-001E-03

The following table shows the RF connector's electrical specifications.

Table 48: Electrical Specifications of 20449-001E-03

Item	Specification
Voltage Rating	60V r.m.s. maximum
Nominal Frequency Range	DC to 6GHz
Nominal Impedance	50Ω
Temperature Rating	-40°C to +90°C
Insulation Resistance	500 MΩ minimum
Withstanding Voltage	No evidence of breakdown
Initial Contact Resistance (without conductor resistance)	Center contact 20.0mΩmax. Outer contact 20.0mΩmax.
Voltage Standing Wave Ratio (V.S.W.R.)	1.3max.(DC~3GHz) 1.45max.(3GHz~6GHz)

To get best RF performance, the RF plug connector should be designed to match the receptacle 20449-001E-03, and the parts come from I-PEX is the recommended.

The following is the mechanical information of the I-PEX's RF coaxial cable GLJ-RH120-1901 for reference. For further technical support, the customer could visit the I-PEX's website or contact the local sales team.

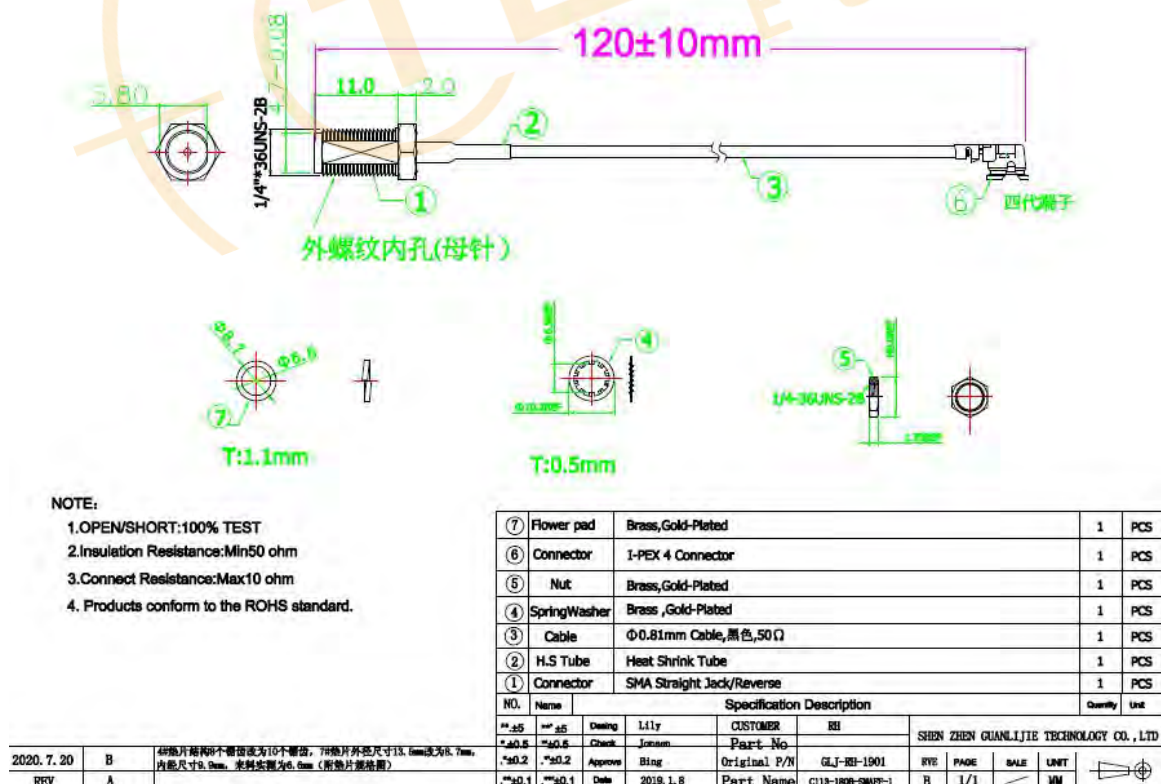

Figure 34: 3D view of 20449-001E-03

5 Electrical Specifications

5.1 Absolute Maximum Ratings

Absolute maximum rating for digital and analog pins of module are listed in the following table.

Table 49: Absolute maximum ratings

Parameter	Min.	Typ.	Max.	Unit
Voltage at VBAT pins	-	-	4.8	V
Voltage at digital pins (GPIO,I2C,UART, I2S)	-	-	2.1	V
Voltage at digital pins ((U)SIM)	-	-	3.05	V
Voltage at FULL_CARD_POWER_OFF#	-	-	4.4	V
Voltage at RESET#	-	-	1.9	V

5.2 Operating Conditions

Table 50: VBAT recommended operating ratings

Parameter	Min.	Typ.	Max.	Unit
Voltage at VBAT	3.135	3.8	4.4	V

Table 51: 1.8V Digital I/O characteristics

Parameter	Description	Min.	Typ.	Max.	Unit
V _{IH}	High-level input voltage	1.17	-	2.1	V
V _{IL}	Low-level input voltage	0	-	0.63	V
V _{OH}	High-level output voltage	1.35	-	1.8	V
V _{OL}	Low-level output voltage	0	-	0.45	V
I _{OZH}	High-level, tri-state leakage current (no pull down resistor)	-	-	1	uA
I _{OZL}	Low-level, tri-state leakage current (no pull up resistor)	-1	-	-	uA

I_{IH}	Input high leakage current (no pull down resistor)	-	-	1	uA
I_{IL}	Input low leakage current(no pull up resistor)	-1	-	-	uA

Table 52: Operating temperature

Parameter	Min.	Typ.	Max.	Unit
Normal operation temperature(3GPP compliant)	-30	-	70	°C
Extended operation temperature*	-40	-	85	°C
Storage temperature	-40	-	90	°C

5.3 Operating Mode

5.3.1 Operating Mode Definition

The table below summarizes the various operating modes of SIM8202E-M2.

Table 53: Operating mode definition

Mode	Function
UMTS/LTE/5G Sleep	AT command “AT+CSCLK=1” can be used to set the module to a sleep mode. In this case, the current consumption of module will be reduced to a very low level and the module can still receive paging message and SMS.
UMTS/LTE/5G Idle	Software is active. Module is registered to the network, and ready to communicate.
Normal operation UMTS/LTE/5G Talk	Connection between two subscribers is in progress. In this case, the power consumption depends on network settings such as DTX off/on, FR/EFR/HR, hopping sequences, and antennas.
UMTS/LTE/5G Standby	Module is ready for data transmission, but no data is currently sent or received. In this case, power consumption depends on network settings.
UMTS/LTE/5G Data transmission	There is data transmission in progress. In this case, power consumption is related to network settings (e.g. power control level); uplink/downlink data rates, etc.
Minimum functionality mode	AT command “AT+CFUN=0” can be used to set the module to a minimum functionality mode without removing the power supply. In this mode, the RF part of the module will not work and the (U)SIM card will not be accessible, but the serial port and USB port are still accessible. The power consumption in this mode is lower than normal mode.
Flight mode	AT command “AT+CFUN=4” or pulling down the W_disable1# pin can

	be used to set the module to flight mode without removing the power supply. In this case, the RF part of the module will not work, but the serial port and USB are still available. The power consumption is lower than normal mode.
Power off	Normally module will go into power off mode by sending the AT command "AT+CPOF" or pull down the FULL_CARD_POWER_OFF# pin. In this mode the power management unit shuts down the power supply, and software is not active. The serial port and USB are not available.

5.3.2 Sleep Mode

In sleep mode, the current consumption of the module will be reduced to a very low level.

Several hardware and software conditions must be satisfied in order to let module enter into sleep mode:

1. UART condition
2. USB condition
3. Software condition

NOTE

Before designing, pay attention to how to realize sleeping/waking function.

5.3.3 Minimum Functionality Mode and Flight Mode

Minimum functionality mode ceases a majority of functions of the module, in order to minimize the power consumption. This mode is set by the AT command which provides a choice of 3 different functionality levels.

- AT+CFUN=0: Minimum functionality
- AT+CFUN=1: Full functionality (Default)
- AT+CFUN=4: Flight mode

If module has been set to minimum functionality mode, the RF (U)SIM card functions will be closed while the serial port and USB are still available.

If module has been set to flight mode, the RF function will be closed while the (U)SIM card, the serial port and USB are still available.

When module is in minimum functionality or flight mode, it can return to full functionality by the AT command "AT+CFUN=1".

5.4 Current Consumption

The current consumptions are listed in the table below.

Table 54: Current consumption on VBAT pins (VBAT=3.8V)

Description	Condition	Typical	Unit
Power off mode	Power off	50	uA
GNSS mode	(AT+CFUN=0, connection USB)	22	mA
Sleep mode (GNSS off, without connection USB)	WCDMA (AT+CFUN=0)	4.8	mA
	WCDMA DRX=1.28s	5.6	mA
	WCDMA DRX=2.56s	5.3	mA
	LTE-FDD (AT+CFUN=0)	4.8	mA
	LTE-FDD DRX=0.32s	8.1	mA
	LTE-FDD DRX=0.64s	6.7	mA
	LTE-FDD DRX=1.28s	5.8	mA
	LTE-FDD DRX=2.56s	5.4	mA
	LTE-TDD (AT+CFUN=0)	4.8	mA
	LTE-TDD DRX=0.32s	8.2	mA
	LTE-TDD DRX=0.64s	6.6	mA
	LTE-TDD DRX=1.28s	5.8	mA
	LTE-TDD DRX=2.56s	5.2	mA
	5G SA		TBD
Idle mode (GNSS off, without connection USB)	WCDMA	11.8	mA
	LTE FDD	12.8	mA
	LTE TDD	12.2	mA
	5G SA	TBD	mA
LTE			
LTE-FDD B1	@5MHz 22.1dBm	TYPE:370.79mA	
	@10MHz 22.1dBm	TYPE:419mA	
	@20MHz 22.0dBm	TYPE:544mA	
LTE-FDD B3	@5MHz 21.4dBm	TYPE:508.7mA	
	@10MHz 21.9dBm	TYPE:536.4mA	
	@20MHz 21.9dBm	TYPE:543.8mA	
LTE-FDD B5	@5MHz 22.4dBm	TYPE:439.1mA	
	@10MHz 22.3dBm	TYPE:430mA	
LTE-FDD B7	@5MHz 21.1dBm	TYPE:581.8mA	
	@10MHz 21.3dBm	TYPE:608.3mA	
	@20MHz 22.4dBm	TYPE:626.6mA	
LTE-FDD B8	@5MHz 22.4dBm	TYPE:487.5mA	
	@10MHz 22.3dBm	TYPE:492.8mA	
LTE-FDD B20	@5MHz 22.3dBm	TYPE:451.2mA	

	@10MHz	22.3dBm	TYPE:453.1mA
LTE-FDD B28	@5MHz	22.5dBm	TYPE:459.6mA
	@10MHz	22.4dBm	TYPE:456.2mA
LTE-TDD B34	@5MHz	22.1dBm	TYPE:502mA
	@10MHz	22.3dBm	TYPE:514.5mA
LTE-TDD B38	@5MHz	22.1dBm	TYPE:510.5mA
	@10MHz	22.1dBm	TYPE:523.8mA
	@20MHz	22.2dBm	TYPE:529.9mA
LTE-TDD B39	@5MHz	22.1dBm	TYPE:416.1mA
	@10MHz	22.2dBm	TYPE:427.7mA
	@20MHz	22.1dBm	TYPE:428.1mA
LTE-TDD B40	@5MHz	21.7dBm	TYPE:480.6mA
	@10MHz	21.7dBm	TYPE:475.5mA
	@20MHz	21.4dBm	TYPE:464.2mA
LTE-TDD B41	@5MHz	21.4dBm	TYPE:711.5mA
	@10MHz	21.4dBm	TYPE:676mA
	@20MHz	21.3dBm	TYPE:668.9mA
LTE-TDD B42	@5MHz	22.7dBm	TYPE: 549.6mA
	@10MHz	23.0dBm	TYPE: 569.8mA
	@20MHz	22.9dBm	TYPE: 562.8mA
LTE-TDD B43	@5MHz	23.0dBm	TYPE: 568.5mA
	@10MHz	22.9dBm	TYPE: 553.4mA
	@20MHz	22.8dBm	TYPE: 563.5mA
LTE-TDD B48	@5MHz	23.2dBm	TYPE: 563.9mA
	@10MHz	23.2dBm	TYPE: 569.9mA
	@20MHz	23.1dBm	TYPE: 564.2mA
5G NR			
5G n1 (15KHz)	@5MHz	23.2dBm	TYPE:550.6 mA
	@10MHz	23.2dBm	TYPE:564.2 mA
	@20MHz	23.1dBm	TYPE:568 mA
5G n3 (15KHz)	@5MHz	22.82dBm	TYPE: 555.69mA
	@10MHz	22.84dBm	TYPE: 549.832mA
	@20MHz	22.78dBm	TYPE: 560.056mA
5G n5 (15KHz)	@5MHz	21.93dBm	TYPE: 455.34mA
	@10MHz	21.72dBm	TYPE: 483.624mA
	@20MHz	21.9dBm	TYPE: 469.862mA
5G n7 (15KHz)	@5MHz	23.52dBm	TYPE: 709.376mA
	@10MHz	23.57dBm	TYPE: 697.264mA
	@20MHz	23.82dBm	TYPE: 709.376mA
5G n8 (15KHz)	@5MHz	22.17dBm	TYPE: 473.115mA
	@10MHz	22.15dBm	TYPE: 489.571mA
	@20MHz	22.2dBm	TYPE: 486.658mA
5G n20 (15KHz)	@5MHz	21.96dBm	TYPE: 444.452mA
	@10MHz	21.91dBm	TYPE: 449.709mA
	@20MHz	22.01dBm	TYPE: 457.464mA

5G n28 (15KHz)	@5MHz	21.8dBm	TYPE: 451.975mA
	@10MHz	21.8dBm	TYPE: 458.563mA
5G n38 (30KHz)	@20MHz	23.84dBm	TYPE: 693.579mA
5G n40 (30KHz)	@20MHz	22.36dBm	TYPE: 499.404mA
	@60MHz	21.91dBm	TYPE: 565.338mA
	@80MHz	21.71dBm	TYPE: 585.025mA
5G n41 (30KHz)	@50MHz	25.79dBm	TYPE: 1367.53mA
	@80MHz	26.13dBm	TYPE: 1434.22mA
	@100MHz	26.02dBm	TYPE: 1417.78mA
5G n77 (30KHz)	@50MHz	23.98dBm	TYPE: 1419.48mA
	@80MHz	24.24dBm	TYPE: 1416.91mA
	@100MHz	24.26dBm	TYPE: 1385.64mA
5G n78 (30KHz)	@50MHz	24.25dBm	TYPE: 1392.68mA
	@80MHz	23.76dBm	TYPE: 1390.46mA
	@100MHz	23.70dBm	TYPE: 1335.77mA
5G n79 (30KHz)	@50MHz	25.72dBm	TYPE: 1296.74mA
	@80MHz	25.37dBm	TYPE: 1289.18mA
	@100MHz	25.81dBm	TYPE: 1291.64mA

NOTE

1. The current consumption of table52 only for reference, please refer to actual current consumption.

5.5 RF Output Power

The RF output power is shown in the following table.

Table 55: Conducted output power

Bands	Max	Min
WCDMA Bands	23dBm + 1/-3dB	<-50dBm
LTE-FDD Bands	23dBm + 2/-2dB	<-40dBm
LTE-TDD Bands	23dBm + 2/-2dB	<-40dBm
5G Sub-6 Bands	23dBm + 2/-2dB	<-40dBm



5.6 Conducted Receive Sensitivity

The conducted RF receiving sensitivity is shown in the following table.

Table 56: Conducted RF receiving sensitivity

Bands	Primary (Typ.)	Diversity (Typ.)	Main/Div (Typ.)	4X4MIMO (Worst Case)
WCDMA B1	-107.5dBm	TBD	TBD	TBD
WCDMA B3	-105.5dBm	TBD	TBD	TBD
WCDMA B5	-105.5dBm	TBD	TBD	TBD
WCDMA B8	-104.5dBm	TBD	TBD	TBD
LTE B1	@20MHz -95.4dBm	@20MHz -96.6dBm	TBD	TBD
LTE B3	@20MHz -94.5dBm	@20MHz -96.4dBm	TBD	TBD
LTE B5	@10MHz -95.1dBm	TBD	TBD	TBD
LTE B7	@20MHz -94.1dBm	@20MHz -94.4dBm	TBD	TBD
LTE B8	@10MHz -98.1dBm	@10MHz -100.6dBm	TBD	TBD
LTE B12	@10MHz -96.9dBm	@10MHz -101.1dBm	TBD	TBD
LTE B13	@5MHz -101.9dBm	@5MHz -103.4dBm	TBD	TBD
LTE B14	@5MHz -98.4dBm	@5MHz -103.1dBm	TBD	TBD
LTE B17	@5MHz -99.9dBm	@5MHz -102.6dBm	TBD	TBD
LTE B18	TBD	@10MHz -101.4dBm	TBD	TBD
LTE B19	@5MHz -99.6dBm	@5MHz -99.3dBm	TBD	TBD
LTE B20	@20MHz -96.2dBm	@20MHz -98.1dBm	TBD	TBD
LTE B25	TBD	TBD	TBD	TBD
LTE B26	@5MHz -98.9dBm	@5MHz -103.7dBm	TBD	TBD
LTE B28	@5MHz -100.4dBm	@5MHz -103.2dBm	TBD	TBD
LTE B29	TBD	TBD	TBD	TBD
LTE B30	TBD	TBD	TBD	TBD

LTE B34	@5MHz -99.2dBm	@5MHz -101.7dBm	TBD	TBD
LTE B38	@20MHz -95.4dBm	@20MHz -96.2dBm	TBD	TBD
LTE B39	@20MHz -96.4dBm	@20MHz -96.6dBm	TBD	TBD
LTE B40	@20MHz -96.1dBm	@20MHz -96.6dBm	TBD	TBD
LTE B41	@20MHz -94.9dBm	@20MHz -96.1dBm	TBD	TBD
LTE B42	TBD	TBD	TBD	TBD
LTE B42	TBD	TBD	TBD	TBD
LTE B48	TBD	TBD	TBD	TBD
LTE B71	@20MHz -95.4dBm	TBD	TBD	TBD
5G n1 (15KHz)	@20MHz -95.2dBm	TBD	TBD	TBD
5G n3 (15KHz)	@20MHz -96.1dBm	TBD	TBD	TBD
5G n5	TBD	TBD	TBD	TBD
5G n7 (15KHz)	@20MHz -94.6dBm	TBD	TBD	TBD
5Gn8	TBD	TBD	TBD	TBD
5Gn12	TBD	TBD	TBD	TBD
5Gn20	TBD	TBD	TBD	TBD
5Gn28 (15KHz)	@20MHz -96dBm	TBD	TBD	TBD
5Gn38 (30KHz)	@20MHz -95.5dBm	TBD	TBD	TBD
5Gn40 (30KHz)	@80MHz -89.5dBm	TBD	TBD	TBD
5Gn41 (30KHz)	@100MHz -89.4dBm	TBD	TBD	TBD
5Gn48	TBD	TBD	TBD	TBD
5Gn66	TBD	TBD	TBD	TBD
5Gn71	TBD	TBD	TBD	TBD
5Gn77 (30KHz)	@100MHz -89.6dBm	TBD	TBD	TBD
5Gn78 (30KHz)	@100MHz -89dBm	TBD	TBD	TBD
5Gn79 (30KHz)	@100MHz -89.6dBm	TBD	TBD	TBD

5.7 Thermal Design

Make sure that the SIM8202E-M2 can reach maximum work performance under extended temperature or extreme conditions for a long time, thermal dissipation design is very important.

It is strongly recommended to add a thermal pad on the customer's main PCB, and add thermally conductive material between the module and the main PCB. The thermal dissipation area on bottom side of the module and the dimensions is shown in the following figure. The size of recommended thermal dissipation area is 30.5mm*26mm. The dimensions are measured in mm.

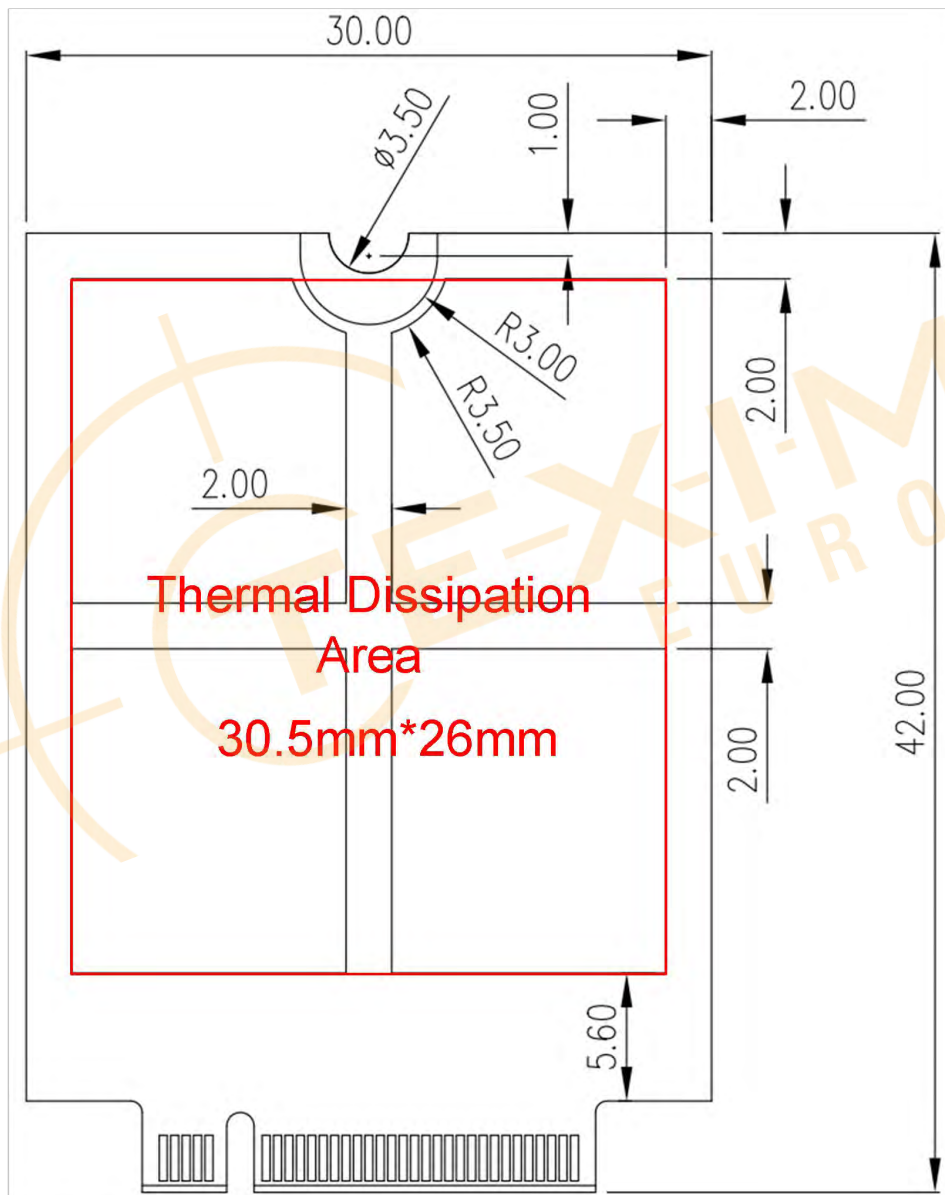

Figure 35: Thermal dissipation area on bottom side of the module

There are some design rules to enhance thermal dissipation performance:

- Keep the module away from other heat sources such as battery, power, AP, etc.
- Make sure that the module mounting holes connect to the main PCB ground fully.
- Add enough through via on the main PCB. Via material is very important solid copper and stacked via

is better.

- Make sure maximize airflow around the module.
- Recommend use heat dissipation material connect to the customer's devices on the top side of the module to enhance the heat dissipation. Large thermal dissipation area is better.
- Chose a high effective heat dissipation material is better such as heat pipe, graphite sheets. The recommend thermal conductivity is 8w/m-k.



5.8 ESD

SIM8202E-M2 is sensitive to ESD in the process of storage, transporting, and assembling. When module is mounted on the customer's main board, the ESD components should be placed closed to the connectors which human body may touch, such as (U)SIM card holder, audio jacks, switches, USB interface, etc. The following table shows the module ESD test performance.

Table 57: The ESD performance measurement table (Temperature: 25°C, Humidity: 45%)

Part	Contact discharge	Air discharge
VBAT,GND	+/- 4KV	+/- 8KV
Antenna	+/- 4KV	+/- 8KV
FULL_CARD_POWER_OFF#	+/- 3KV	+/- 6KV
USB	+/- 3KV	+/- 6KV
RESET#	+/- 2KV	+/- 5KV
(U)SIM	+/- 2KV	+/- 5KV
Other PAD	+/- 2KV	+/- 5KV

NOTE

Test conditions:

1. The external of the module has surge protection diodes and ESD protection diodes.
2. The data in Table 57 was tested using SIMCom EVB.

6 Appearance

6.1 Top and Bottom View of SIM8202E-M2

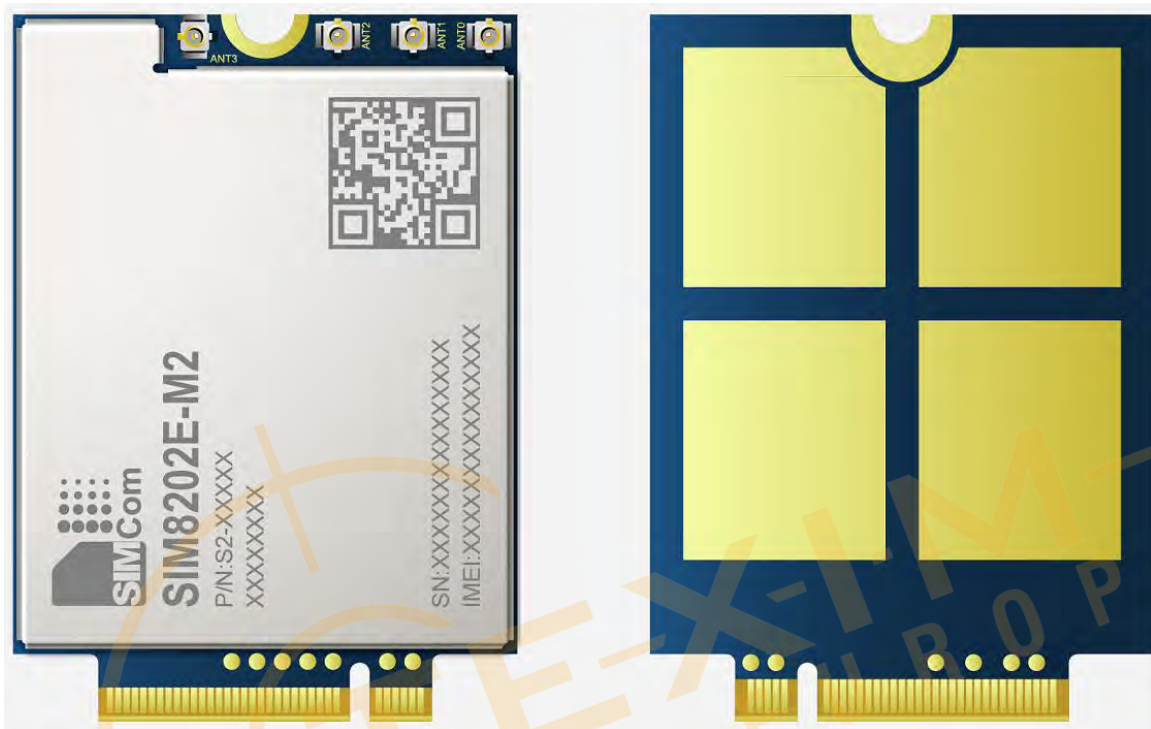

Figure 36: Top and bottom view of the module

6.2 Label Description Information



Figure 37: Label description of the module

Table 58: Label description of the module information

No.	Description
A	LOGO
B	Project name
C	Product code
D	QR code
E	Serial number
F	International mobile equipment identity

NOTE

Figure 36 and Figure 37 are the effect diagrams of the module, for reference only. Please refer to the actual product for appearance.



7 Packaging

SIM8202E-M2 supports tray packaging. The packaging procedures are shown in the following figure.

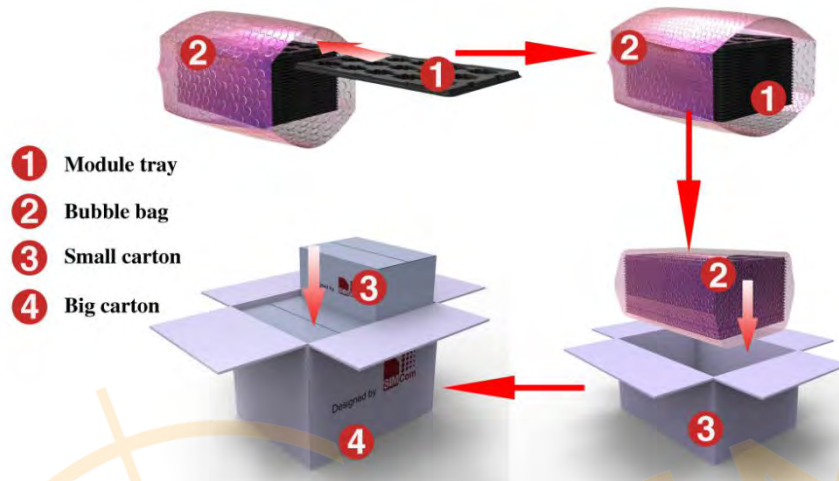

Figure 38: Packaging procedures

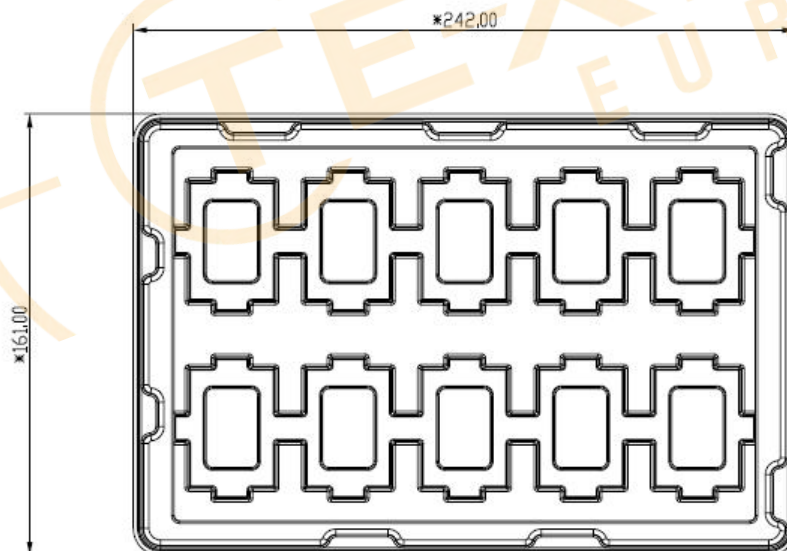

Figure 39: Tray view of the module

Table 59: Tray size

Length ($\pm 3\text{mm}$)	Width ($\pm 3\text{mm}$)	Number
245.0	165.0	10

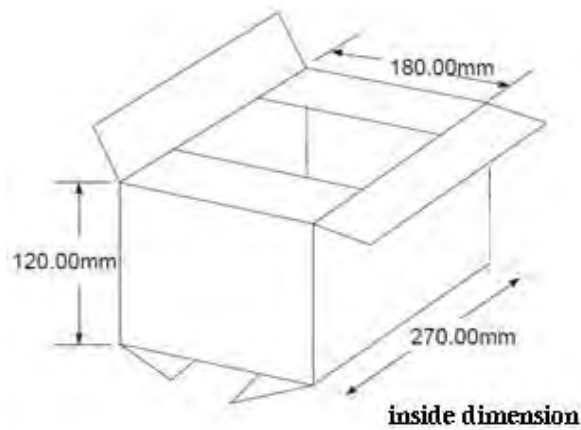

Figure 40: Small carton view

Table 60: Small carton size

Length ($\pm 10\text{mm}$)	Width ($\pm 10\text{mm}$)	Height ($\pm 10\text{mm}$)	Number
270	180	120	10*20=200

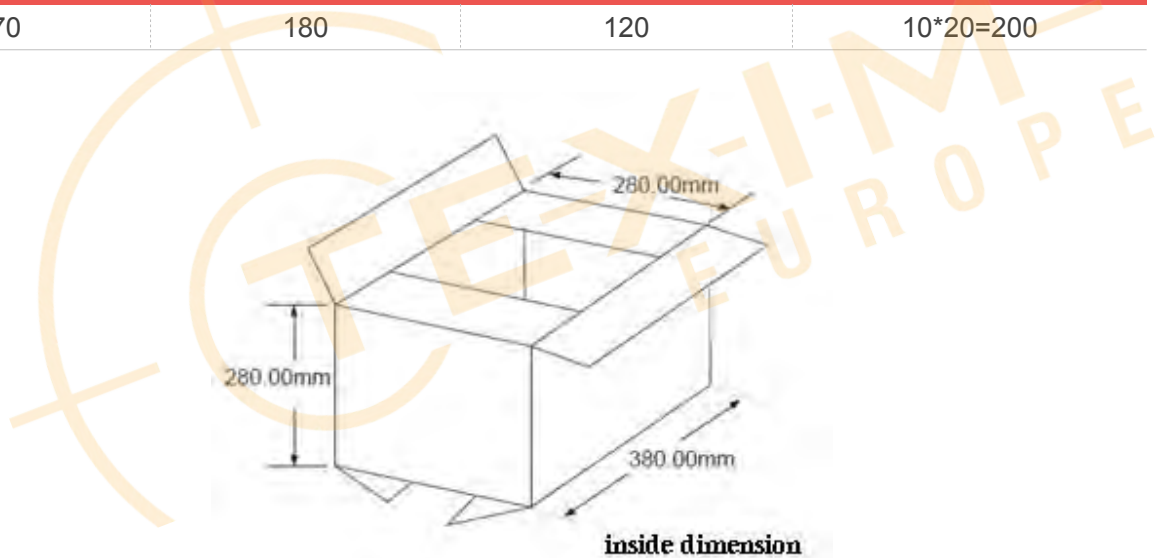

Figure 41: Big carton view

Table 61: Big carton size

Length ($\pm 10\text{mm}$)	Width ($\pm 10\text{mm}$)	Height ($\pm 10\text{mm}$)	Number
380	280	280	200*4=800

8 Appendix

8.1 Coding Schemes and Maximum Net Data Rates over Air Interface

Table 62: Coding schemes and maximum net data rates over air interface

HSDPA device category	Max data rate (peak)	Modulation type
Category 1	1.2Mbps	16QAM,QPSK
Category 2	1.2Mbps	16QAM,QPSK
Category 3	1.8Mbps	16QAM,QPSK
Category 4	1.8Mbps	16QAM,QPSK
Category 5	3.6Mbps	16QAM,QPSK
Category 6	3.6Mbps	16QAM,QPSK
Category 7	7.2Mbps	16QAM,QPSK
Category 8	7.2Mbps	16QAM,QPSK
Category 9	10.2Mbps	16QAM,QPSK
Category 10	14.4Mbps	16QAM,QPSK
Category 11	0.9Mbps	QPSK
Category 12	1.8Mbps	QPSK
Category 13	17.6Mbps	64QAM
Category 14	21.1Mbps	64QAM
Category 15	23.4Mbps	16QAM
Category 16	28Mbps	16QAM
Category 17	23.4Mbps	64QAM
Category 18	28Mbps	64QAM
Category 19	35.5Mbps	64QAM
Category 20	42Mbps	64QAM
Category 21	23.4Mbps	16QAM
Category 22	28Mbps	16QAM
Category 23	35.5Mbps	64QAM
Category 24	42.2Mbps	64QAM
HSUPA device category	Max data rate (peak)	Modulation type
Category 1	0.96Mbps	QPSK
Category 2	1.92Mbps	QPSK
Category 3	1.92Mbps	QPSK
Category 4	3.84Mbps	QPSK
Category 5	3.84Mbps	QPSK

Category 6	5.76Mbps	QPSK
LTE-FDD device category (Downlink)		
LTE-FDD device category (Downlink)	Max data rate (peak)	Modulation type
Category 1	10Mbps	QPSK/16QAM/64QAM
Category 2	50Mbps	QPSK/16QAM/64QAM
Category 3	100Mbps	QPSK/16QAM/64QAM
Category 4	150Mbps	QPSK/16QAM/64QAM
Category 5	300Mbps	QPSK/16QAM/64QAM
Category 6	300Mbps	QPSK/16QAM/64QAM
LTE-FDD device category (Uplink)		
LTE-FDD device category (Uplink)	Max data rate (peak)	Modulation type
Category 1	5Mbps	QPSK/16QAM
Category 2	25Mbps	QPSK/16QAM
Category 3	50Mbps	QPSK/16QAM
Category 4	50Mbps	QPSK/16QAM
Category 5	75Mbps	QPSK/16QAM/64QAM
Category 6	50Mbps	QPSK/16QAM



8.2 Related Documents

Table 63: Related documents

No.	Title	Description
[1]	SIM8200 Series_AT Command Manual	AT Command Manual
[2]	3GPP TS 51.010-1	Digital cellular telecommunications system (Release 5); Mobile Station (MS) conformance specification
[3]	3GPP TS 38.401	NG-RAN; Architecture description
[4]	3GPP TS 34.124	Electromagnetic Compatibility (EMC) for mobile terminals and ancillary equipment.
[5]	3GPP TS 34.121	Electromagnetic Compatibility (EMC) for mobile terminals and ancillary equipment.
[6]	3GPP TS 34.123-1	Technical Specification Group Radio Access Network; Terminal conformance specification; Radio transmission and reception (FDD)
[7]	3GPP TS 34.123-3	User Equipment (UE) conformance specification; Part 3: Abstract Test Suites.
[8]	EN 301 908-02 V2.2.1	Electromagnetic compatibility and Radio spectrum Matters (ERM); Base Stations (BS) and User Equipment (UE) for IMT-2000. Third Generation cellular networks; Part 2: Harmonized EN for IMT-2000, CDMA Direct Spread (UTRA FDD) (UE) covering essential requirements of article 3.2 of the R&TTE Directive
[9]	EN 301 489-24 V1.2.1	Electromagnetic compatibility and Radio Spectrum Matters (ERM); Electromagnetic Compatibility (EMC) standard for radio equipment and services; Part 24: Specific conditions for IMT-2000 CDMA Direct Spread (UTRA) for Mobile and portable (UE) radio and ancillary equipment
[10]	IEC/EN60950-1(2001)	Safety of information technology equipment (2000)
[11]	3GPP TS 51.010-1	Digital cellular telecommunications system (Release 5); Mobile Station (MS) conformance specification
[12]	GCF-CC V3.23.1	Global Certification Forum - Certification Criteria
[13]	2002/95/EC	Directive of the European Parliament and of the Council of 27 January 2003 on the restriction of the use of certain hazardous substances in electrical and electronic equipment (RoHS)
[14]	3GPP TS 38.101	NR radio transmission and reception technical specification
[15]	NSA_ENDC_For_SIM8202E_SDX55-2-210209	ENDC list for SIM8202E

8.3 Terms and Abbreviations







Table 64: Terms and abbreviations

Abbreviation	Description
ADC	Analog-To-Digital Converter
ARP	Antenna Reference Point
BER	Bit Error Rate
BTS	Base Transceiver Station
CS	Coding Scheme
CSD	Circuit Switched Data
CTS	Clear To Send
DAC	Digital-To-Analog Converter
DRX	Discontinuous Reception
DSP	Digital Signal Processor
DTE	Data Terminal Equipment (typically computer, terminal, printer)
DTR	Data Terminal Ready
DTX	Discontinuous Transmission
DPR	Dynamic Power Reduction
DIV	The Diversity Receive signal
EFR	Enhanced Full Rate
EMC	Electromagnetic Compatibility
ESD	Electrostatic Discharge
ETS	European Telecommunication Standard
EVDO	Evolution Data Only
FCC	Federal Communications Commission (U.S.)
FD	(U)SIM fix dialing phonebook
FDD	Frequency Division Dual
FDMA	Frequency Division Multiple Access
FR	Full Rate
GMSK	Gaussian Minimum Shift Keying
GNSS	Global Navigation Satellite System
GPS	Global Positioning System
HR	Half Rate
HSPA	High Speed Packet Access
HSIC	High-Speed Inter-Chip
I2C	Inter-Integrated Circuit
I2S	Inter-IC Sound
IMEI	International Mobile Equipment Identity
LTE	Long Term Evolution
LB	Low Frequency Band
LAA	Limited Access Authorization

MO	Mobile Originated
MSB	Most Significant Bit
MHB	Middle And High Frequency Band
MT	Mobile Terminated
MIMO	Multiple Input Multiple Output
NMEA	National Marine Electronics Association
PAP	Password Authentication Protocol
PBCCH	Packet Switched Broadcast Control Channel
PCB	Printed Circuit Board
PCIe	Peripheral Component Interface Express
RF	Radio Frequency
RMS	Root Mean Square (value)
RTC	Real Time Clock
SIM	Subscriber Identification Module
SMS	Short Message Service
SPI	Serial Peripheral Interface
SMPS	Switched-Mode Power Supply
TDD	Time Division Dual
TDMA	Time Division Multiple Access
TE	Terminal Equipment(also referred to as DTE)
TX	Transmit Direction
TRX	The Diversity Receive signal
VSWR	Voltage Standing Wave Ratio
SM	(U)SIM Phonebook
SGMII	Serial Gigabit Media Independent Interface
NC	Not connect
HSDPA	High Speed Downlink Packet Access
HSUPA	High Speed Uplink Packet Access
ZIF	Zero Intermediate Frequency
WCDMA	Wideband Code Division Multiple Access
VCTCXO	Voltage Control Temperature-Compensated Crystal Oscillator
(U)SIM	Universal Subscriber Identity Module
UHB	Ultra High Frequency Band
UMTS	Universal Mobile Telecommunications System
UART	Universal Asynchronous Receiver Transmitter

8.4 Safety Caution

Table 65: Safety caution

Marks	Requirements
	When in a hospital or other health care facility, observe the restrictions about the use of mobiles. Switch the cellular terminal or mobile off, medical equipment may be sensitive and not operate normally due to RF energy interference.
	Switch off the cellular terminal or mobile before boarding an aircraft. Make sure it is switched off. The operation of wireless appliances in an aircraft is forbidden to prevent interference with communication systems. Forgetting to think much of these instructions may impact the flight safety, or offend local legal action, or both.
	Do not operate the cellular terminal or mobile in the presence of flammable gases or fumes. Switch off the cellular terminal when you are near petrol stations, fuel depots, chemical plants or where blasting operations are in progress. Operation of any electrical equipment in potentially explosive atmospheres can constitute a safety hazard.
	Your cellular terminal or mobile receives and transmits radio frequency energy while switched on. RF interference can occur if it is used close to TV sets, radios, computers or other electric equipment.
	Road safety comes first! Do not use a hand-held cellular terminal or mobile when driving a vehicle, unless it is securely mounted in a holder for hands free operation. Before making a call with a hand-held terminal or mobile, park the vehicle.
	<p>Mobiles operate over radio frequency signals and cellular networks and cannot be guaranteed to connect in all conditions, especially with a mobile fee or an invalid (U)SIM card. While you are in this condition and need emergent help, please remember to use emergency calls. In order to make or receive calls, the cellular terminal or mobile must be switched on and in a service area with adequate cellular signal strength.</p> <p>Some networks do not allow for emergency call if certain network services or phone features are in use (e.g. lock functions, fixed dialing etc.). You may have to deactivate those features before you can make an emergency call.</p> <p>Also, some networks require that a valid (U)SIM card be properly inserted in the cellular terminal or mobile.</p>

Disclaimer

ALL PRODUCTS, PRODUCT SPECIFICATIONS AND DATA ARE SUBJECT TO CHANGE WITHOUT NOTICE TO IMPROVE RELIABILITY, FUNCTION OR DESIGN OR OTHERWISE.

Texim Europe B.V. its affiliates, agents, and employees, and all persons acting on its or their behalf (collectively, "Texim"), disclaim any and all liability for any errors, inaccuracies or incompleteness contained in any datasheet or in any other disclosure relating to any product.

Texim makes no warranty, representation or guarantee regarding the suitability of the products for any particular purpose or the continuing production of any product.

It is the customer's responsibility to validate that a particular product with the properties described in the product specification is suitable for use in a particular application.

Parameters provided in datasheets and / or specifications may vary in different applications and performance may vary over time.

All operating parameters, including typical parameters, must be validated for each customer application by the customer's technical experts.

Please contact us if you have any questions about the contents of the datasheet.

This may not be the latest version of the datasheet. Please check with us if a later version is available.

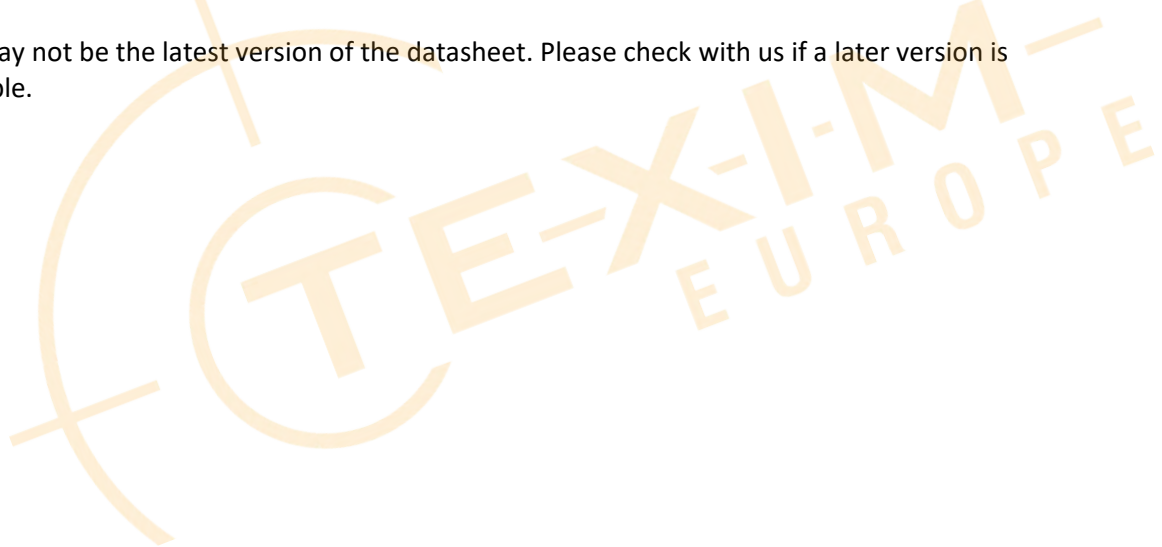



Headquarters & Warehouse

Elektrostraat 17
NL-7483 PG Haaksbergen
The Netherlands

T: +31 (0)53 573 33 33
E: info@texim-europe.com
Homepage: www.texim-europe.com



The Netherlands

Elektrostraat 17
NL-7483 PG Haaksbergen

T: +31 (0)53 573 33 33
E: nl@texim-europe.com



Belgium

Zuiderlaan 14, box 10
B-1731 Zellik

T: +32 (0)2 462 01 00
E: belgium@texim-europe.com



UK & Ireland

St Mary's House, Church Lane
Carlton Le Moorland
Lincoln LN5 9HS

T: +44 (0)1522 789 555
E: uk@texim-europe.com



Germany - North

Bahnhofstrasse 92
D-25451 Quickborn

T: +49 (0)4106 627 07-0
E: germany@texim-europe.com



Germany - South

Martin-Kollar-Strasse 9
D-81829 München

T: +49 (0)89 436 086-0
E: muenchen@texim-europe.com



Austria

Warwitzstrasse 9
A-5020 Salzburg

T: +43 (0)662 216 026
E: austria@texim-europe.com



Nordic

Søndre Jagtvej 12
DK-2970 Hørsholm

T: +45 88 20 26 30
E: nordic@texim-europe.com



Italy

Via Matteotti 43
IT-20864 Agrate Brianza (MB)

T: +39 (0)39 9713293
E: italy@texim-europe.com