

Magnetic rotary angle and position sensor-control.

Through-hole contactless sensor.

MTS-360PCB

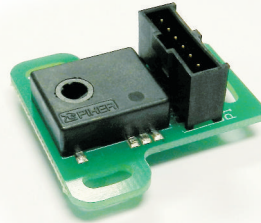

Designed with the sensor directly mounted onto a PCB, the innovative MTS-360 Sensor/PCB Combo package allows engineers to easily mount a fully featured rotary sensor without first having to design a printed circuit board for the sensor. The result is time-savings and convenience.

The MTS-360 Sensor/PCB assembly is available with or without 2.54 mm pitch connector, both easily secured with standard M3 screws. The entire assembly measures just 35mm wide by 36mm long, allowing for applications with tight packaging constraints.

The new MTS-360PCB Mechanical Mount sensor model incorporates all the breakthrough sensor technology performance features of the original MTS-360 by merging a through-shaft design with 360° absolute position feedback in a small size package. The result is an extremely small fully featured rotary sensor with reliability up to 50 million cycles. The MTS-360 relies on patented Hall effect technology to enable true non-contacting through-hole shaft sensing now using a simple three eared mounting. The standard model features a 4mm double D-flat through-hole and (3) slotted mounting holes allowing final rotational adjustment at assembly.

Mechanical specifications

Rotational life (depends on application and mounting)		up to 50.000.000 cycles.
Operating temperature ¹	with connector	up to -40°C to +105
	without connector	up to -40°C to +125°C
Sealing ¹		IP50

Electrical specifications

Linearity ¹	±1% absolute (±0.5% check availability).
Angular range	Programmable from 15 to 360 degrees (without dead band).
Output	Analog (Ratiometric), PWM, Serial Protocol.
Switch output	Yes, programmable.
Angular Resolution (depends on electrical angle and rotational speed)	Analog & PWM: up to 12 bits.
	Serial Protocol (SPI): up to 14 bits.
Operating temperature	-40°C to +85°C (-13°F to + 158°F)
Supply voltage ¹	5V ±10%
Supply current	Typ 8.5mA for single version. Typ 17mA for redundant version.

¹ Others check availability.

Piher Sensors & Controls SA

Our product competencies and services:
Potentiometers | Position / angle sensors | Rotary switches | Incremental encoders
Printed circuit resistors | Mechatronics | Value added assemblies

Distributed by:  www.texim-europe.com

Key features

- Simple & robust magnetic design.
- Low profile.
- Multiturn.
- Two programmable switch outputs (6 pin version).
- Programmable Linear Transfer Characteristic:
(some positive slopes & one negative slope can be programmed in the same transfer characteristic;
up to 4 programmable points; see last page).
- Self-diagnostic features.
- Over voltage protection and reverse voltage protection.
- Shaft insertable from both sides.

Also upon request:

- True full redundant version.

Applications

- Non-Contacting long life angle/position sensor.
- Absolute rotary position sensor
- Pedal position Sensor.
- Optical imaging stabilization.
- Biomedical devices.
- Optical zoom devices.
- Consumer electronics.
- HVAC systems.
- Automotive control systems.
- Marine controls.
- Fork lift trucks.
- Farm equipment.
- Sports and recreational equipment.
- Unmanned vehicles and aircraft.
- Industrial vehicles.
- Instrumentation.
- Valve position sensors.
- Robotic and automation feedback system.

MEGGITT
smart engineering for
extreme environments

Magnetic rotary angle and position sensor-control.

Through-hole contactless sensor.

MTS-360PCB

How to order.

3 pin version - Simple output (analogic / PWM)

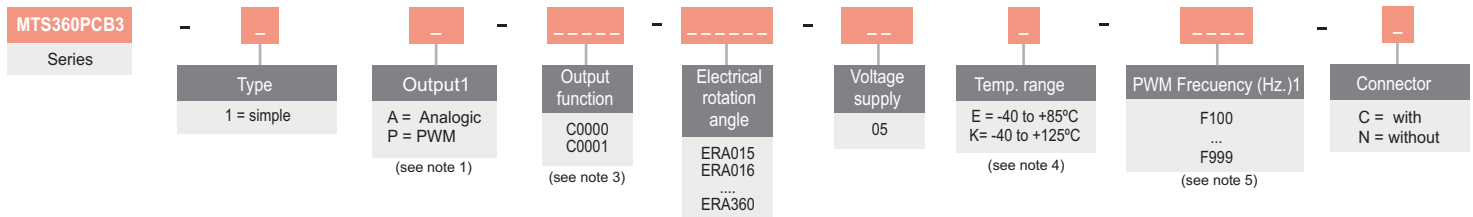

6 pin version - Simple output (analogic / PWM)

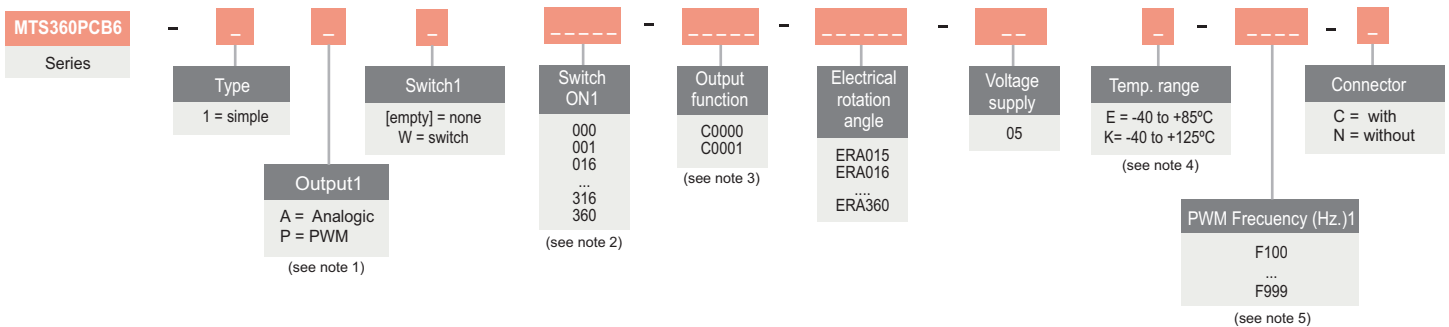

6 pin version - Redundant output (analogic / PWM)

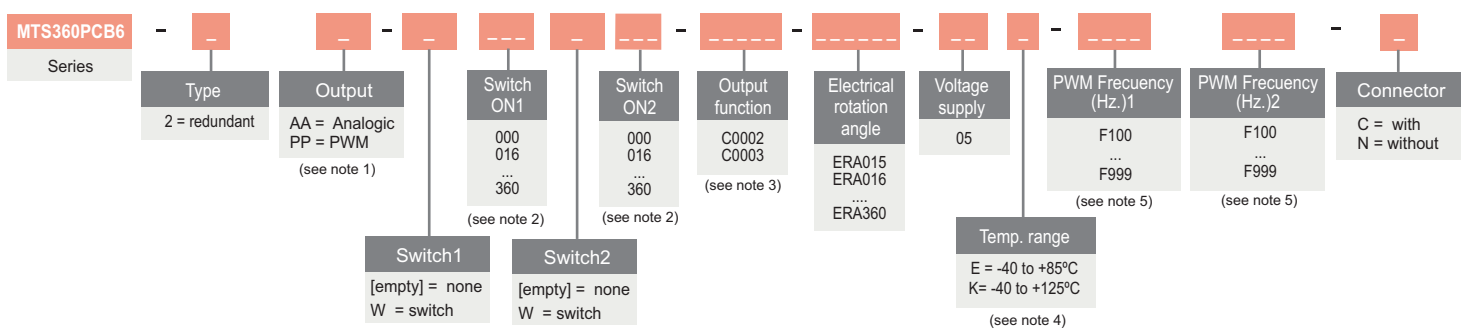

Other product configurations will be studied case by case.

Notes

(1) The analog output is a ratiometric output, proportional to input supply voltage.

(2) Leave empty if no applicable.

Switch function diagram:

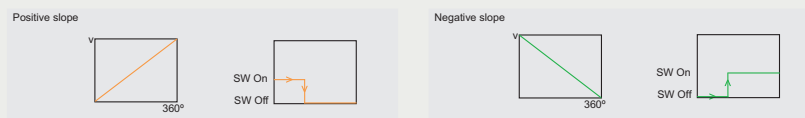

(3) Other output functions available check availability. In the How To Order reference, enter CXXXX meanwhile the new output function reference is not defined.

(4) If "with" connector, then K is limited to +105°C

(5) Leave empty if no applicable. Default frequency is 200 Hz

Piher Sensors & Controls SA

Our product competencies and services:
Potentiometers | Position / angle sensors | Rotary switches | Incremental encoders
Printed circuit resistors | Mechatronics | Value added assemblies

Distributed by: www.texim-europe.com

MEGGITT
smart engineering for
extreme environments

Magnetic rotary angle and position sensor-control.

Through-hole contactless sensor. MTS-360PCB

Options

- Special outputs slopes and protocols.
- Full redundant version with switches.
- Energy harvesting versions.
- Fast versions.
- Connectors.
- IP sealing.
- Shaft interfaces.
- Contact the factory for other options.

Dimensions

6 pin version

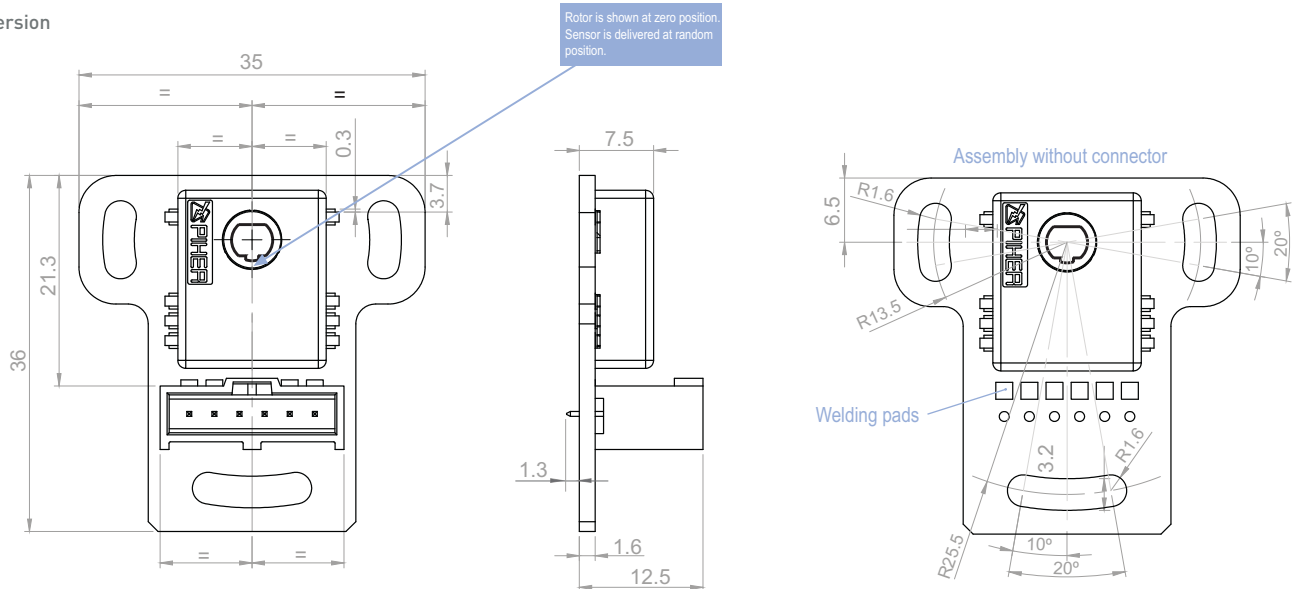

3 pin version

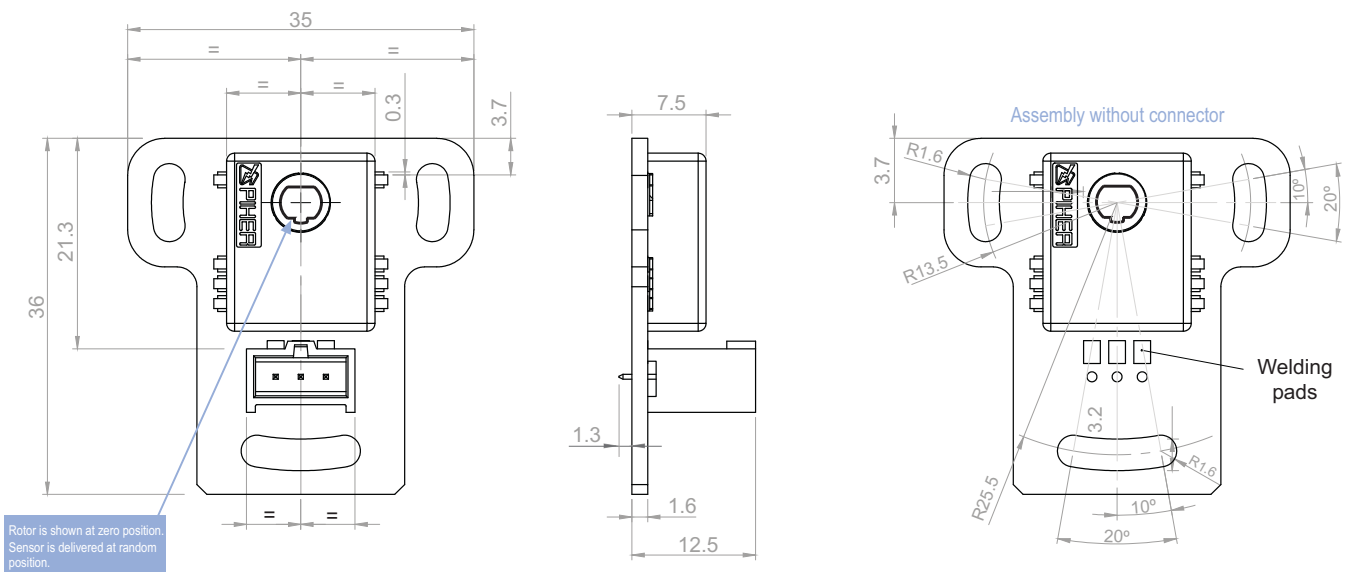

Piher Sensors & Controls SA

Our product competencies and services:
Potentiometers | Position / angle sensors | Rotary switches | Incremental encoders
Printed circuit resistors | Mechatronics | Value added assemblies



Magnetic rotary angle and position sensor-control.

Through-hole contactless sensor. MTS-360PCB

Mounting instructions.



Electronic semiconductor products are sensitive to Electro Static Discharge (ESD).
Always observe Electro Static Discharge control procedures whenever handling semiconductor products.

Connections scheme.

Detail of header connector for 3 pin version. (Molex 90136-1203)

Recommended mate connector:

Molex 90156-0143

Recommended crimp terminals:

Molex 90119-2120
Molex 90119-2121
Molex 90119-2122

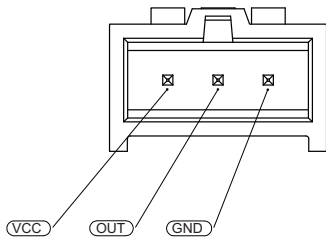

Detail of header connector for 6 pin version. (Molex 90136-1206)

Recommended mate connector:

Molex 90156-0146

Recommended crimp terminals:

Molex 90119-2120
Molex 90119-2121
Molex 90119-2122

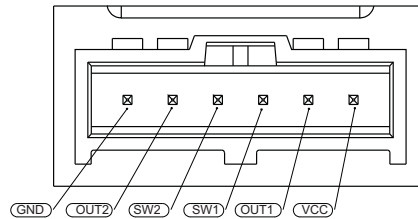

Output.

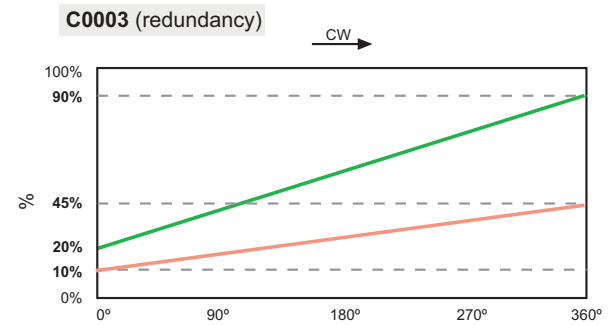
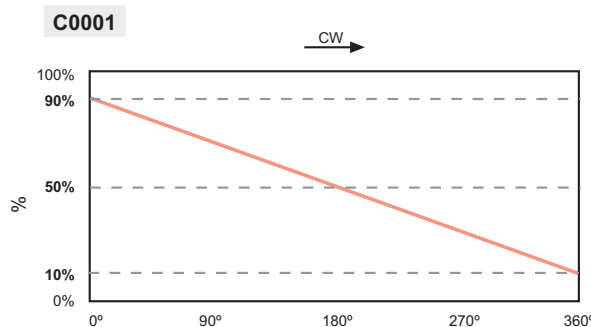
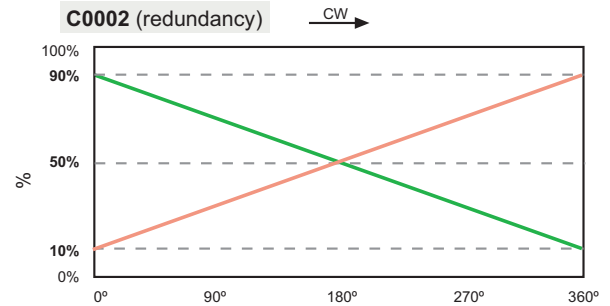
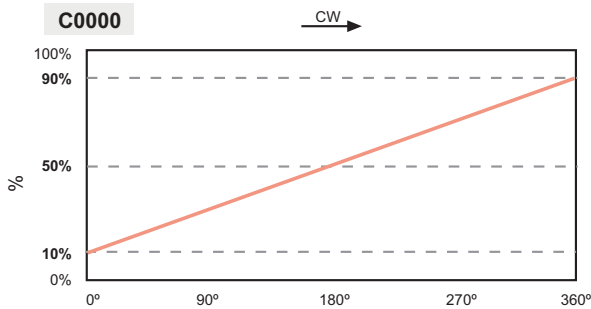

Piher Sensors & Controls SA

Our product competencies and services:
Potentiometers | Position / angle sensors | Rotary switches | Incremental encoders
Printed circuit resistors | Mechatronics | Value added assemblies



Magnetic rotary angle and position sensor-control.

Through-hole contactless sensor. MTS-360PCB

Disclaimer

The product information in this catalogue is for reference purposes. Please consult for the most up to date and accurate design information.

Piher Sensors & Controls S.A., its affiliates, agents, and employees, and all persons acting on its or their behalf (collectively, "Piher"), disclaim any and all liability for any errors, inaccuracies or incompleteness contained herein or in any other disclosure relating to any product described herein.

Piher disclaims any and all liability arising out of the use or application of any product described herein or of any information provided herein to the maximum extent permitted by law. The product specifications do not expand or otherwise modify Piher's terms and conditions of sale, including but not limited to the warranty expressed therein, which apply to these products.

No licence, express or implied, by estoppel or otherwise, to any intellectual property rights is granted by this document or by any conduct of Piher.

The products shown herein are not designed for use in medical, life-saving, or life-sustaining applications unless otherwise expressly indicated. Customers using or selling Piher products not expressly indicated for use in such applications do so entirely at their own risk and agree to fully indemnify Piher for any damages arising or resulting from such use or sale. Please contact authorised Piher personnel to obtain written terms and conditions regarding products designed for such applications.

Product names and markings noted herein may be trademarks of their respective owners.

Information contained in and/or attached to this catalogue may be subject to export control regulations of the European Community, USA, or other countries. Each recipient of this document is responsible to ensure that usage and/or transfer of any information contained in this document complies with all relevant export control regulations. If you are in any doubt about the export control restrictions that apply to this information, please contact the sender immediately. For any Piher International Corp. Exports, Note: All products / technologies are EAR99 Classified commodities. Exports from the United States are in accordance with the Export Administration Regulations. Diversion contrary to US law is prohibited.

Contact

Piher Sensors & Controls SA

Polígono Industrial Municipal
Vial T2 Nº22
31500 Tudela - Spain
Tel: +34-948-820450

piher.sales@meggitt.com

www.piher.net
www.meggitt.com



All Piher products can be adapted to meet customer's requirements.
Due to continuous process improvement, specifications are subject to change without notice.
Please always use the datasheets published at our website www.piher.net for the most up-to-date information.

v230616

Piher Sensors & Controls SA

Our product competencies and services:

Potentiometers | **Position / angle sensors** | Rotary switches | Incremental encoders
Printed circuit resistors | Mechatronics | Value added assemblies

Distributed by:  www.texim-europe.com

MEGGITT
smart engineering for
extreme environments

The Netherlands



Elektrostraat 17
NL-7483 PG Haaksbergen

T: +31 (0)53 573 33 33
F: +31 (0)53 573 33 30
E: nl@texim-europe.com

Belgium



Zuiderlaan 14 bus 10
B-1731 Zellik

T: +32 (0)2 462 01 00
F: +32 (0)2 462 01 25
E: belgium@texim-europe.com

UK & Ireland



St. Mary's House, Church Lane
Carlton Le Moorland
Lincoln LN5 9HS

T: +44 (0)1522 789 555
F: +44 (0)845 299 22 26
E: uk@texim-europe.com

Germany North



Bahnhofstrasse 92
D-25451 Quickborn

T: +49 (0)4106 627 07-0
F: +49 (0)4106 627 07-20
E: germany@texim-europe.com

Germany South



Martin-Kollar-Strasse 9
D-81829 München

T: +49 (0)89 436 086-0
F: +49 (0)89 436 086-19
E: germany@texim-europe.com

Austria



Warwitzstrasse 9
A-5020 Salzburg

T: +43 (0)662 216 026
F: +43 (0)662 216 026-66
E: austria@texim-europe.com

Nordic region



Sdr. Jagtvej 12
DK-2970 Hørsholm

T: +45 88 20 26 30
F: +45 88 20 26 39
E: nordic@texim-europe.com

General information



info@texim-europe.com
www.texim-europe.com