



# Shenzhen Leadtek Electronics Co.,Ltd

## PRODUCT SPECIFICATION

### TFT-LCD MODULE

**Module No: LTK070MNHLM34-V0**

Preliminary Specification

Approval Specification

Designed by	Checked by	Approved by
<i>jona</i>	<i>tom</i>	<i>lan</i>

### Final Approval by Customer

Approved by	Comment

※The specification of "TBD" should refer to the measured value of sample . If there is difference between the design specification and measured value, we naturally shall negotiate and agree to solution with customer.





## 1.0 General Description

### 1.1 Introduction

LTK070MNHLM34-V0 Display model 7.0" LCM is a color active matrix thin film transistor (TFT) liquid crystal display (LCD) that uses amorphous silicon TFT as a switching device. This model is composed of a TFT LCD panel and a driving circuit .This TFT LCD has a 7.0(1:5) inch diagonally measured active display area with (280horizontal by1424 vertical pixel) resolution.

	Item	Specification	Unit	Remark
1	LCD Size	7		-
2	Panel Type	IPS		
4	Resolution	280 x R G B x 1424	pixel	-
5	Display Mode	Normally Black	-	-
6	Number of Colors	16.7M		-
7	Viewing Direction	ALL FULL	-	-
8	NTSC	66%		TYP
9	Contrast Ratio	1000		TYP
10	Luminance	450	n	TYP
11	LCM+CTP Outline Dimension	38.20 (W) x181.47(L) x3.4(H)	mm	Note
12	Panel Active Area	33.60 (W) x 170.88(L)	mm	Note
13	Pixel Pitch	0.12(H) x0.12(V)	mm	-
14	Weight	TBD		-
15	Driver IC	OTA7290B		-
16	Driver IC RAM Size	RAMLESS	bit	-
17	Light Source	8 white LED in 8S1P	-	-
18	Interface	MIPI	-	
19	Operating Temperature	-20~+70	°C	-
20	Storage Temperature	-30~+80	°C	-

## 2.0 Absolute Maximum Ratings

### 2.1 Electrical Absolute Rating

Item	Symbol	Min.	Max.	Unit	Note
Power supply voltage	VDD	-0.3	3.6	V	GND=0
	VCC	-0.3	1.6	V	GND=0

Note (1) Stresses above those listed under "Absolute Maximum Rating" may cause permanent damage to the device. These are stress ratings only. Functional operation of this device at indicated in the operational sections(6.1) of this specification.

### 2.2 Back-light Unit:

PARAMETER	Sympol	Min.	Typ.	Max.	Unit	Test Condition	Note
LED Current	IF	–	40	–	mA	–	–
LED Voltage	VF	–	25.6	–	V	IF=40mA	–
Luminance (on the modulesurface ,BM-7 )	LV	–	450	–	cd/m2	IF=40mA	–
Color temperature (@CA210)		8000	9000	10000	K	IF=40mA	–
Life Time		–	30000	–	Hr.	IF=40mA	–
Color	White						

Note (1) Permanent damage may occur to the LCD module if beyond this specification. Functional operation should be restricted to the conditions described under normal operating conditions.

(2)Ta=25±2

(3)Test condition: LED Current 40mA

## 2.3. Electrical Specifications(Typical Operation Conditions, At Ta = 25 °C)

ITEM	SYMBOL	MIN	TYP	MAX	UNIT	NOTE
Power Supply Voltage	VDD	2.8	3.3	3.4	V	-
	VCC	-	1.6	-	V	-

## 2.4. FUNCTIONAL DESCRIPTIONS

### 2.4.1. Power On/Off Sequence

In order to prevent IC from power on reset fail, the rising time ( $T_{POR}$ ) of the digital power supply VDD should be maintained within the given specifications. Refer to "AC Characteristics" for more detail on timing.

#### Power-On/Off Timing Sequence:

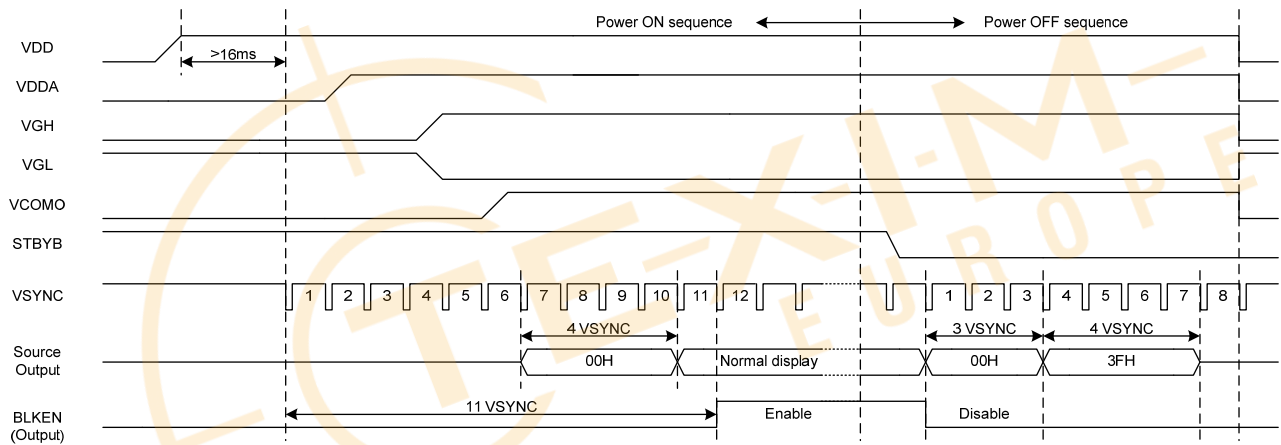

#### Enter and Exit Standby Mode Sequence:

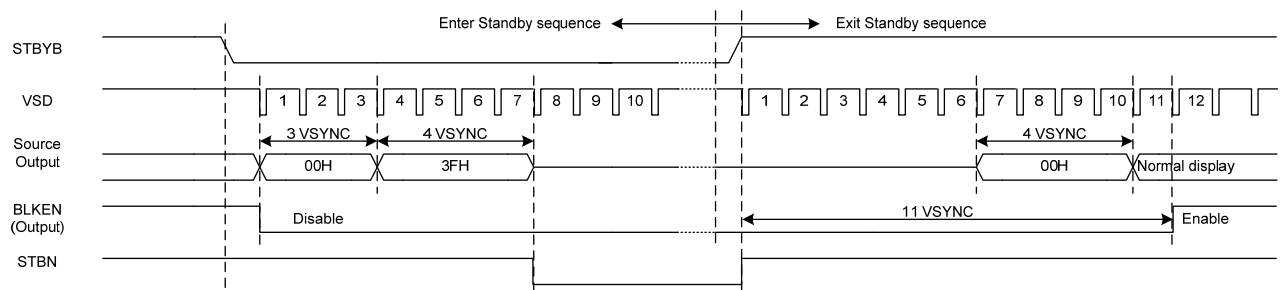

### 3.0 MIPI Interface(Mobile Industry Processing Interface)

The Display Serial Interface (DSI) specifies the interface between a host processor and a peripheral. DSI builds on existing MIPI Alliance specifications by adopting pixel formats and command set specified in DPI-2, DBI-2 and DCS standards.

Figure 7.1 shows a simplified DSI interface. DSI sends display data or commands to the peripheral, and can read back status or pixel information from the peripheral. The main difference is that DSI serializes all pixel data, commands, and events that, in traditional or legacy interfaces, are normally conveyed to and from the peripheral on a parallel data bus with additional control signals.

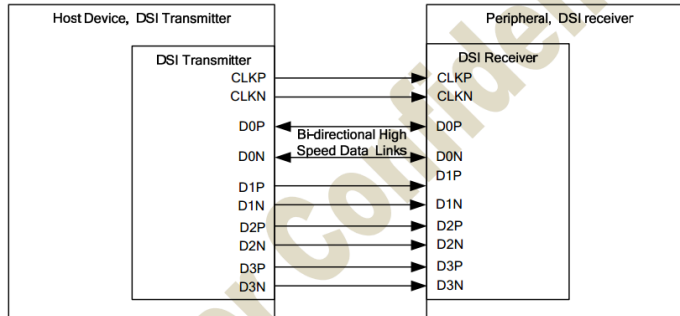

### 3.1. Input Timing Table

280RGBx1424 (4 Data Lanes)

Parameter	Symbol	Min.	Typ.	Max.	Unit
MIPI data frequency	FDATA	120	160	170	Mbps
Horizontal display area	THD	280			pixel
HS period time	TH	286	320	360	pixel
HS pulse width	THPW	-	6	-	pixel
HS back porch	THBP	-	12	-	pixel
HS front porch	THFP	-	12	-	pixel
Vertical display area	TVD	1424			H
VS period time	TV	1085	1460	1480	H
VS pulse width	TVPW	-	12	-	H
VS back porch	TVBP	20			H
VS front porch	TVFP	-	20	-	H

## 4.0 OPTICAL CHARACTERISTICS

### 4.1 Optical Specification

Item	Symbol	Condition	Min.	Typ.	Max.	Unit	Note	
Transmittance (with Polarizer)	T (%)	$\Theta=0$ Normal viewing angle	4.03	4.53	—	%	Measuring with normal polarizer , Reference Only Base on $V_{op}=5.5V$	
Transmittance (without Polarizer)	T (%)		10.9	15.2	—	%		
Contrast Ratio	CR		800	1000	—	—	(1)(2)	
Response Time	$T_{R+T_F}$		—	30	40	msec	(1)(3)	
Color Gamut	(%)			60	—	%	C-light	
Color Chromaticity (CIE1931)	White		$W_x$	-0.02	0.321	+0.02	—	(1)(4) CF glass C-light
			$W_y$		0.345		—	
	Red		$R_x$		0.642		—	
			$R_y$		0.331		—	
	Green		$G_x$		0.320		—	
		$G_y$	0.568		—			
	Blue	$B_x$	0.136		—			
		$B_y$	0.120		—			
Viewing Angle	Hor.	$\Theta_L$	75	80			(1)(4) Measuring with normal polarizer Reference Only	
		$\Theta_R$	75	80				
	Ver.	$\Theta_U$	75	80	—			
		$\Theta_D$	75	80	—			
Optima View Direction			Free		—		(5)	

The information contained in this document is the exclusive property of Leadtek Display Corporation. It shall not be disclosed, distributed or reproduced in whole or in part without written permission of Leadtek Display Corporation.

### 4.2 Measuring Condition

- Measuring surrounding : dark room
- Ambient temperature :  $25\pm 2^{\circ}\text{C}$
- 15min. warm-up time.

### 4.3 Measuring Equipment

- FPM520 of Westar Display technologies, INC., which utilized SR-3 for Chromaticity and BM-5A for other optical characteristics.

Note (1) Definition of Viewing Angle:

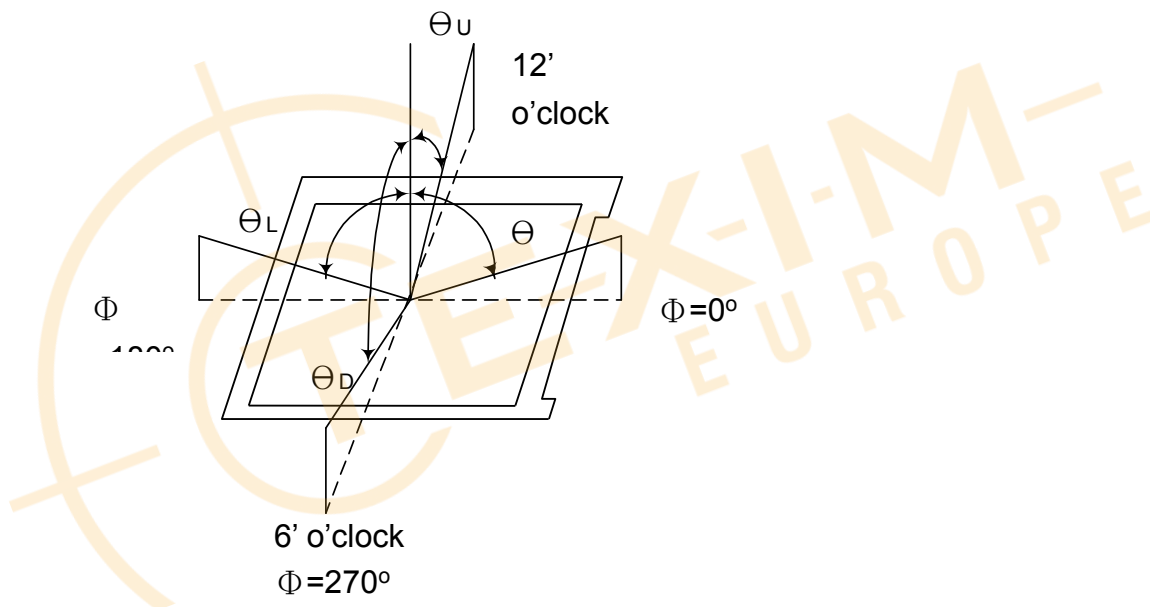

Note (2) Definition of Contrast Ratio (CR) :

Measured at the center point of panel

$$\text{CR} = \frac{\text{Luminance with all pixels white}}{\text{Luminance with all pixels black}}$$



Note (3) Definition of Response Time: Sum of  $T_R$  and  $T_F$

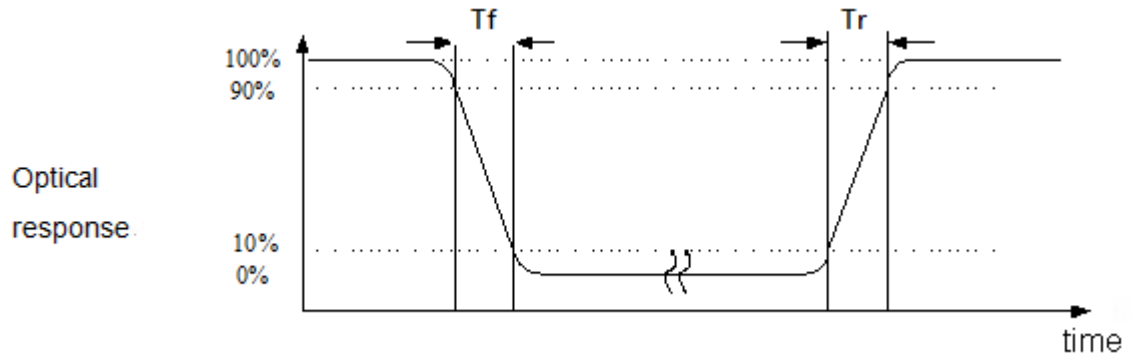

Note (4) Definition of optical measurement setup

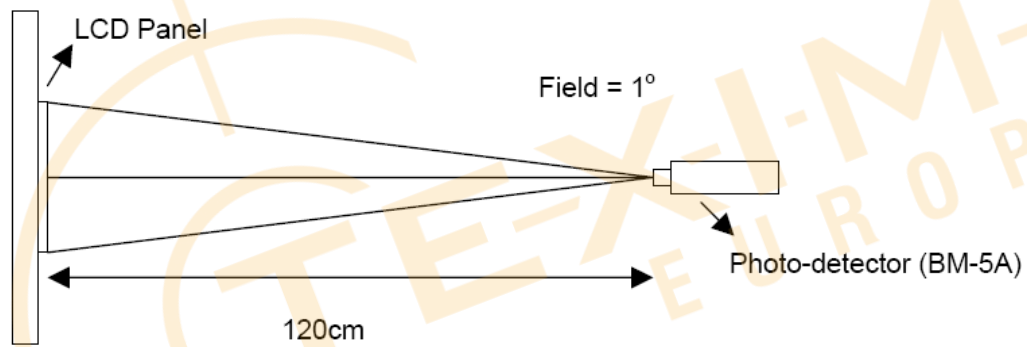

## 5.0 Interface Pin Connection

### 5.1 TFT LCD Module

PIN NO	SYMBOL	DESCRIPTION
1	GND	Power Ground
2	D0P	MIPI DSI differential data 0 positive
3	D0N	MIPI DSI differential data 0 negative
4	GND	Power Ground
5	D1P	MIPI DSI differential data 1 positive
6	D1N	MIPI DSI differential data 1 negative
7	GND	Power Ground
8	CLKP	MIPI DSI differential clock positive
9	CLKN	MIPI DSI differential clock negative
10	GND	Power Ground
11	D2P	MIPI DSI differential data 2 positive
12	D2N	MIPI DSI differential data 2 negative
13	GND	Power Ground
14	D3P	MIPI DSI differential data 3 positive
15	D3N	MIPI DSI differential data 3 negative
16	GND	Power Ground
17	GND	Power Ground
18	NC	Not connect
19	NC	Not connect
20	NC	Not connect
21	NC	Not connect
22	NC	Not connect
23	NC	Not connect
24	RESET	Global reset pin. Follow VDD Voltage.
25	STBYB	Standby mode, Normally pulled high
26	NC	Not connect
27	GND	Power Ground
28	K	Backlight LED
29	K	Backlight LED
30	GND	Power Ground
31	NC	Not connect
32	GND	Power Ground
33	GND	Power Ground
34	NC	Not connect
35	A	Backlight LED+
36	A	Backlight LED+
37	GND	Power Ground
38	VDD	Power Voltage for digital circuit (3.3V)
39	VDD	Power Voltage for digital circuit (3.3V)
40	NC	Not connect

## 6. Mechanical Drawing

# Front View

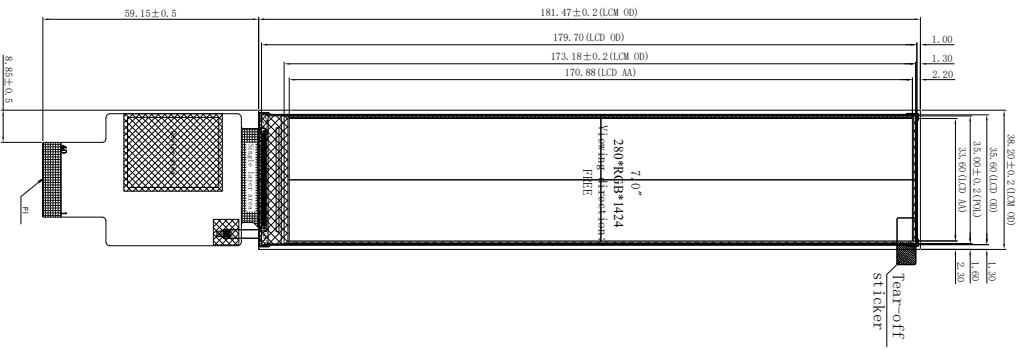

# Side View

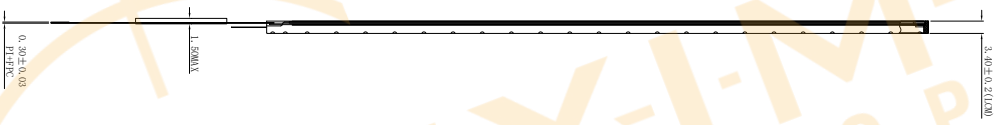

# Back View

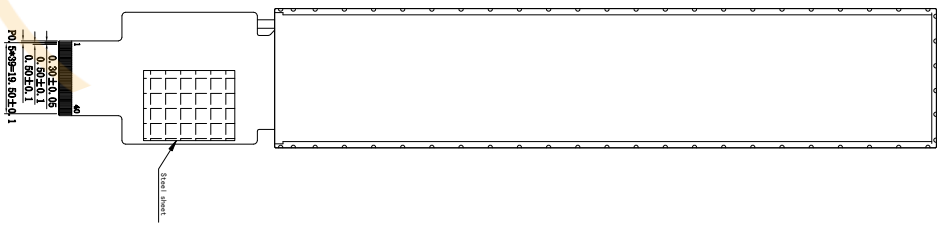

PIN	DESCRIPTION
1	GND
2	DOP
3	DOIN
4	GND
5	DIP
6	D1IN
7	GND
8	CLAP
9	CLAN
10	GND
11	D2P
12	D2N
13	GND
14	D3P
15	D3N
16	GND
17	GND
18	NC
19	NC
20	NC
21	NC
22	NC
23	NC
24	KS1B
25	STR1B
26	NC
27	GND
28	K
29	K
30	GND
31	NC
32	GND
33	GND
34	NC
35	A
36	A
37	GND
38	VDD-3.3V
39	VDD-3.3V
40	NC

- Notes:
1. Display : 7.0", TFT
  2. Resolution: 280xRGBx1424
  3. LCD Viewing Direction: ALL,
  4. Drive IC:0TA7290B
  5. Display Mode: Normally Black
  6. LCM Brightness: 450cd/m<sup>2</sup> (TYP), uniformity ≥80%
  7. unmark Tolerance: ± 0.2
  8. OPERATING TEMP: -20 °C ~ + 70 °C
  9. STORAGE TEMP: - 30 °C ~ + 80 °C
  10. Requirements on Environmental Protection:

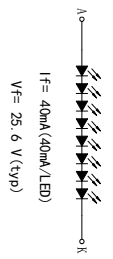

REV	DESCRIPTION	DATE	NAME
3			
2			
1	NEW	2023.03.07	IAN

**LEADTEK DISPLAY**

**LEADTEK COMPANY LIMITED**

SCALE: 1/1 UNIT: mm PAGE: 1/1

Part No: LTK070MNHLM34 VER: V0

Customer No:

Approve: [Signature] Check: JONA Drawn: IAN

## 7. RELIABILITY TEST

### Reliability test conditions ( Polarizer characteristics null )

No.	Items	Condition	Inspection after test
1	High Temperature Storage	T = 80°C ± 2°C for 48 hr	Inspection after 4 hours storage at room temperature, the sample shall be free from defects: 1. Air bubble in the LCD 2. Sealleak; 3. Non-display; 4. missing segments; 5. Glass crack; 6. Current Idd is twice higher than initial value.
2	Low Temperature Storage	T = -30°C ± 2°C for 48 hr	
3	High Temperature Operating	T = 70°C ± 2°C for 48 hr	
4	Low Temperature Operating	T = -20°C ± 2°C for 48 hr (But no condensation of dew)	
5	High Temp. and High Humidity Operating	T = 60°C ± 5°C /90% for 48 hr (But no condensation dew)	
6	Thermal Shock	-20±2°C~25~70±2°C×10cycles (30min.) (5min.) (30min.)	
7	Dropping test (non-operation)	Drop to the ground from 76cm height, one time, every side of carton. (Packing condition)	
8	Packing Vibration (non-operation)	Frequency: 10Hz~55Hz~10Hz Amplitude: 1.0mm, X, Y, Z direction for total 3hours (Packing condition)	
9	ESD	Voltage:±6KV R: 330Ω C: 150pF Air discharge, 10time	

Note:

- (1) The test samples should be applied to only one test item.
- (2) Sample size for each test item is 5~10pcs.
- (3) In case of malfunction defect caused by ESD damage, if it would be recovered to normal state after resetting, it would be judge as a good part.  
Using ionizer(an antistatic blower) is recommended at working area in order to reduce electro-static voltage.  
When removing protection film from LCM panel, peel off the tag slowly ( recommended more than one second) while blowing with ionizer toward the peeling face to minimize ESD which may damage electrical circuit.
- (4) Please use automatic switch testing mode when test operating mode.

## 8.0 INSPECTION CRITERION

This specification is made to be used as the standard acceptance/rejection criteria for Normal LCM Product.

### 1 .Sample plan

Sampling plan according to GB/T2828.1-2003/ISO 2859-1: 1999 and ANSI/ASQC Z1.4-1993,normal level 2 and based on:

Major defect: AQL 0.65

Minor defect: AQL 1.0

### 2. Inspection condition

Viewing distance for cosmetic inspection is about 30cm with bare eyes, and under an environment of 20~40W light intensity, all directions for inspecting the sample should be within 45° against perpendicular line. (Normal temperature 20~25°C and normal humidity 60±15%RH).

### 3. Definition of inspection zone in LCD.

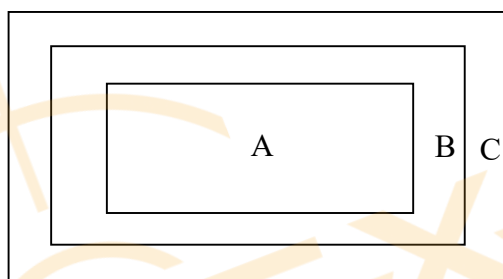

Zone A: character/Digit area

Zone B: viewing area except Zone A (Zone A + Zone B=minimum Viewing area)

Zone C: Outside viewing area (invisible area after assembly in customer's product)

Fig.1 Inspection zones in an LCD.

Note: As a general rule, visual defects in Zone C are permissible, when it is no trouble for quality and assembly of customer's product.

## 9.0 Standards of inspection items

### 9.1 Major Defect

Item No	Items to be inspected	Inspection Standard	Classification of defects
9.1.1	All functional defects	1.No display	Major
		2.Display abnormally	
		3.Missing vertical, horizontal segment	

		4.Short circuit	
		5. Back-light no lighting, flickering and abnormal lighting.	
9.1.2	Missing	Missing component	
9.1.3	Outline dimension	Overall outline dimension beyond the drawing is not allowed.	
9.1.4	linearity	No more than 1.5%	

### 10. 0 Cosmetic Defect

Item No	Items to be inspected	Inspection Standard			Classification of defects			
10.1.1	Clear Spots Black and white Spot defect Pinhole, Foreign Particle, polarizer Dirt	For dark/white spot, size $\Phi$ is defined as $\Phi = (x + y)/2$			Minor			
		1						
		Zone		Acceptable Qty				
		Size(mm)		A		B	C	
		$\Phi \leq 0.15$		Ignore		Ignore		
		$0.15 < \Phi \leq 0.20$		2				
		$0.20 < \Phi \leq 0.30$		1				
	$\Phi > 0.30$		0					
	Clear Spots TP Dirt	2				Minor		
		Zone		Acceptable Qty				
		Size(mm)		A			B	C
		$\Phi \leq 0.15$		Ignore			Ignore	
		$0.15 < \Phi \leq 0.20$		2				
		$0.20 < \Phi \leq 0.30$		1				
	$\Phi > 0.30$		0					
Dim Spots Circle shaped and dim edged defects	3			Minor				
	Zone		Acceptable Qty					
	Size(mm)		A		B	C		
	$\Phi \leq 0.2$		Ignore		Ignore			
$0.20 < \Phi \leq 0.40$		2						

		$0.40 < \Phi \leq 0.60$	1			
		$\Phi > 0.60$	0			
Item No	Items to be inspected	Inspection Standard			Classification of defects	
10.2.2	Line defect Black line, White line, Foreign material on polarizer	Size(mm)		Acceptable Qty		
		L(Length)	W(Width)	Zone		
				A	B	C
		Ignore	$W \leq 0.05$	Ignore		Minor
		$L \leq 5.0$	$0.05 < W \leq 0.08$	2		
			$W > 0.08$	0		
10.2.2	Foreign material on TP film	The line can be seen after mobile phone in the operating condition:				
		Size(mm)		Acceptable Qty		
		L(Length)	W(Width)	Zone		
				A	B	C
		Ignore	$W \leq 0.05$	Ignore		Minor
		$L \leq 5.0$	$0.05 < W \leq 0.08$	3		
	$W > 0.08$	0				
10.2.3	Dim line defect Polarizer scratch TP film scratch	If the scratch can be seen after mobile phone cover assembling or in the operating condition, judge by the line defect of 4.2.2. If the scratch can be seen only in non-operating condition or some special angle, judge by the following.				
		Size(mm)		Acceptable Qty		
		L(Length)	W(Width)	Zone		
				A	B	C
		Ignore	$W \leq 0.03$	Ignore		Minor
		$5.0 < L \leq 10.0$	$0.03 < W \leq 0.05$	2		
$L \leq 5.0$	$0.05 < W \leq 0.08$	1				
	$W > 0.08$	0				
10.2.4	Polarize Air bubble	Air bubbles between glass & polarizer				
		Zone		Acceptable Qty		
		Size(mm)		A	B	C
		$\Phi \leq 0.20$		Ignore		Ignore
		$0.20 < \Phi \leq 0.3$		2		

		$\Phi > 0.30$	0	
--	--	---------------	---	--

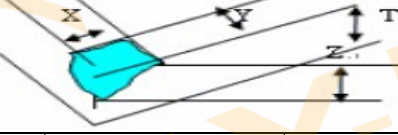
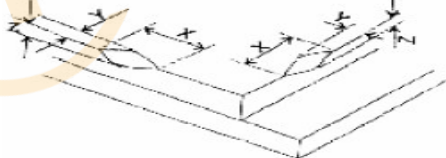
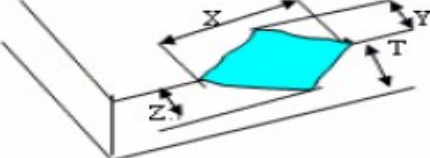
Item No	Items to be inspected	Inspection Standard			Classification of defects
10.2.5	Glass defect	(i) Chips on corner A:LCD Glass defect			Minor
					
		X(mm)	Y(mm)	Z(mm)	
		≤3.0	≤3.0	Disregard	
		Notes: S=contact pad length Chips on the corner of terminal shall not be allowed to extend into the ITO pad or expose perimeter seal. B:TP Glass defect			
					
		X(mm)	Y(mm)	Z(mm)	
		≤3.0	≤3.0	Disregard	
		(ii) Usual surface cracks A:LCD Glass defect			
					
		X(mm)	Y(mm)	Z(mm)	
		≤3.0	<Inner border line of the seal	Disregard	
B:TP Glass defect					
					
X(mm)	Y(mm)	Z(mm)			
≤6.0	<2.0	Disregard			
(iii) Crack Cracks tend to break are not allowed.					



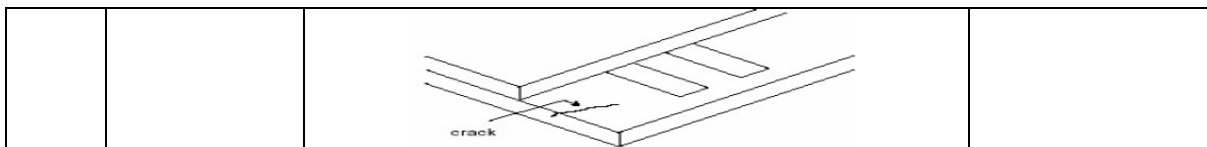

## 11. 0 0PRECAUTIONS FOR USE OF LCD MODULES

### 1. Handling Precautions

- (1) The display panel is made of glass and polarizer. As glass is fragile. It tends to become or chipped during handling especially on the edges. Please avoid dropping or jarring. Do not subject it to a mechanical shock by dropping it or impact.
- (2) If the display panel is damaged and the liquid crystal substance leaks out, be sure not to get any in your mouth. If the substance contacts your skin or clothes, wash it off using soap and water.
- (3) Do not apply excessive force to the display surface or the adjoining areas since this may cause the color tone to vary. Do not touch the display with bare hands. This will stain the display area and degraded insulation between terminals (some cosmetics are determined to the polarizer).
- (4) The polarizer covering the display surface of the LCD module is soft and easily scratched. Handle this polarizer carefully. Do not touch, push or rub the exposed polarizers with anything harder than an HB pencil lead (glass, tweezers, etc.). Do not put or attach anything on the display area to avoid leaving marks on. Condensation on the surface and contact with terminals due to cold will damage, stain or dirty the polarizer. After products are tested at low temperature they must be warmed up in a container before coming is contacting with room temperature air.
- (5) If the display surface becomes contaminated, breathe on the surface and gently wipe it with a soft dry cloth. If it is heavily contaminated, moisten cloth with one of the following solvents
  - Isopropyl alcohol
  - Ethyl alcohol

Do not scrub hard to avoid damaging the display surface.
- (6) Solvents other than those above-mentioned may damage the polarizer. Especially, do not use the following.
  - Water
  - Ketone
  - Aromatic solvents

Wipe off saliva or water drops immediately, contact with water over a long period of time may cause deformation or color fading. Avoid contacting oil and fats.
- (7) Exercise care to minimize corrosion of the electrode. Corrosion of the electrodes is accelerated by water droplets, moisture condensation or a current flow in a high-humidity environment.
- (8) Install the LCD Module by using the mounting holes. When mounting the LCD module make sure it is free of twisting, warping and distortion. In particular, do not forcibly pull or bend the IO cable or the backlight cable.

- (9) Do not attempt to disassemble or process the LCD module.
- (10) NC terminal should be open. Do not connect anything.
- (11) If the logic circuit power is off, do not apply the input signals.
- (12) Electro-Static Discharge Control, Since this module uses a CMOS LSI, the same careful attention should be paid to electrostatic discharge as for an ordinary CMOS IC. To prevent destruction of the elements by static electricity, be careful to maintain an optimum work environment.
  - Before remove LCM from its packing case or incorporating it into a set, be sure the module and your body have the same electric potential. Be sure to ground the body when handling the LCD modules.
  - Tools required for assembling, such as soldering irons, must be properly grounded. Make certain the AC power source for the soldering iron does not leak. When using an electric screwdriver to attach LCM, the screwdriver should be of ground potentiality to minimize as much as possible any transmission of electromagnetic waves produced sparks coming from the commutator of the motor.
  - To reduce the amount of static electricity generated, do not conduct assembling and other work under dry conditions. To reduce the generation of static electricity be careful that the air in the work is not too dried. A relative humidity of 50%-60% is recommended. As far as possible make the electric potential of your work clothes and that of the work bench the ground potential
  - The LCD module is coated with a film to protect the display surface. Exercise care when peeling off this protective film since static electricity may be generated
- (13) Since LCM has been assembled and adjusted with a high degree of precision, avoid applying excessive shocks to the module or making any alterations or modifications to it.
- (14) Do not alter, modify or change the shape of the tab on the metal frame.
- (15) Do not make extra holes on the printed circuit board, modify its shape or change the positions of components to be attached.
- (16) Do not damage or modify the pattern writing on the printed circuit board.
- (17) Absolutely do not modify the zebra rubber strip (conductive rubber) or heat seal connector.
- (18) Except for soldering the interface, do not make any alterations or modifications with a soldering iron.
- (19) Do not drop, bend or twist LCM.
- (20)

## 12. Packing Assembly Drawings

TBD



## **Disclaimer**

ALL PRODUCTS, PRODUCT SPECIFICATIONS AND DATA ARE SUBJECT TO CHANGE WITHOUT NOTICE TO IMPROVE RELIABILITY, FUNCTION OR DESIGN OR OTHERWISE.

Texim Europe B.V. its affiliates, agents, and employees, and all persons acting on its or their behalf (collectively, "Texim"), disclaim any and all liability for any errors, inaccuracies or incompleteness contained in any datasheet or in any other disclosure relating to any product.

Texim makes no warranty, representation or guarantee regarding the suitability of the products for any particular purpose or the continuing production of any product.

It is the customer's responsibility to validate that a particular product with the properties described in the product specification is suitable for use in a particular application.

Parameters provided in datasheets and / or specifications may vary in different applications and performance may vary over time.

All operating parameters, including typical parameters, must be validated for each customer application by the customer's technical experts.

Please contact us if you have any questions about the contents of the datasheet.

This may not be the latest version of the datasheet. Please check with us if a later version is available.





## Headquarters & Warehouse

Elektrostraat 17  
NL-7483 PG Haaksbergen  
The Netherlands

T: +31 (0)53 573 33 33  
E: info@texim-europe.com  
Homepage: www.texim-europe.com



### The Netherlands

Elektrostraat 17  
NL-7483 PG Haaksbergen

T: +31 (0)53 573 33 33  
E: nl@texim-europe.com



### Belgium

Zuiderlaan 14, box 10  
B-1731 Zellik

T: +32 (0)2 462 01 00  
E: belgium@texim-europe.com



### UK & Ireland

St Mary's House, Church Lane  
Carlton Le Moorland  
Lincoln LN5 9HS

T: +44 (0)1522 789 555  
E: uk@texim-europe.com



### Germany - North

Bahnhofstrasse 92  
D-25451 Quickborn

T: +49 (0)4106 627 07-0  
E: germany@texim-europe.com



### Germany - South

Martin-Kollar-Strasse 9  
D-81829 München

T: +49 (0)89 436 086-0  
E: muenchen@texim-europe.com



### Austria

Warwitzstrasse 9  
A-5020 Salzburg

T: +43 (0)662 216 026  
E: austria@texim-europe.com



### Nordic

Søndre Jagtvej 12  
DK-2970 Hørsholm

T: +45 88 20 26 30  
E: nordic@texim-europe.com



### Italy

Martin-Kollar-Strasse 9  
D-81829 München

T: +49 (0)89 436 086-0  
E: italy@texim-europe.com