

Distributed by:



www.texim-europe.com

Datasheet

InnoAGE™

M.2 S80 3TI7

- The World's first hybrid SSD with an Azure Sphere inside
- End-to-end security from edge to cloud
- Hardware level allows easy and simple development
- Supports out-of-band network management and diverse platforms
- Supports wireless 2.4/5GHz dual-band 802.11 a/b/g/n WiFi
- Supports Ethernet

Introduction

The InnoAGE™ SSD comes with a Microsoft Azure Sphere inside, and is further integrated with Innodisk's customized firmware, software, and hardware technology. This new solution enables multifunctional management: smart data analysis and updates, data security, and remote control through the cloud, while benefitting from the power of the Azure Sphere to guarantee secured communications between the SSD and the cloud.

The InnoAGE™ SSD delivers an easy-to-use interface with its customized cloud management platform. In technical terms, the Innodisk-developed firmware receives commands from the Azure Sphere via a second connection to Azure. Therefore, it is able to execute SSD debugging messages as well as monitor read/write behavior patterns to increase the storage device's lifespan. Most importantly, system operators can quickly revert to the default settings from the cloud-based dashboard in the case of a device or system crash.

In other words, the InnoAGE™ SSD is designed for both in-band and out-of-band network management, providing full recovery even when the operating system has crashed or is severely impaired to the extent that in-band management would be of little help.

Contact us for more information about the InnoAGE M.2 (S80) 3TI7

Innodisk is a service-driven provider of industrial embedded flash and DRAM storage products and technologies, with a focus on the industrial/embedded, aerospace and defense, and cloud computing industries.



Headquarters (Taiwan)

5F., No.237, Sec. 1, Datong Rd., Xizhi Dist., New Taipei City, Taiwan (R.O.C.)
Tel: +886-2-77033000
Email: sales@innodisk.com

Branch Offices:

USA
usasales@innodisk.com
+1-510-770-9421
Europe
eusales@innodisk.com
+31-40-3045-400
Japan
jpsales@innodisk.com
+81-3-6667-0161
China
sales_cn@innodisk.com
+86-755-21673689
www.innodisk.com

© 2020 Innodisk Corporation.
All right reserved. Specifications are subject to change without prior notice.

20200416

Specifications

Interface	SATA III
Flash Type	3D TLC
Capacity	64GB~512GB
Flash Endurance	3,000 P/E cycles
Max. Channels	4
Sequential R/W (MB/sec, max.)*	560 / 330 MB/s
4KB Random (QD32) R/W (IOPS)**	85,000/70,000
Max. Power Consumption	3W
Thermal Sensor	✓
ATA Security	✓
S.M.A.R.T.	✓
Dimension (WxLxH)	22.00 X 80.00 X 3.50 mm
Environment	Vibration: 20G @7~2000Hz Shock: 1500G @ 0.5ms Storage Temperature: -55°C to +95°C MTBF: 3 million hours
* Performance based on CrystalDiskMark 5.01 with file size 1000MB	

Quick Erase	Security Erase	Destroy	Recovery	iAnalyzer	S.M.A.R.T.
V	V	V	V	V	V
iData Guard	iPower Guard	ATA Security	TRIM	AES 256bits	
V	V	V	V	V	

Ordering Information

Capacity	Standard Temperature (0°C~70°C)	Industrial Temperature (-40°C~85°C)
64GB	DTM28-64GDK1EC*DFXXG	DTM28-64GDK1EW*DFXXG
128GB	DTM28-A28DK1EC*QFXXG	DTM28-A28DK1EW*QFXXG
256GB	DTM28-B56DK1EC*QFXXG	DTM28-B56DK1EW*QFXXG
512GB	DTM28-C12DK1EC*QFXXG	DTM28-C12DK1EW*QFXXG
Note	XXG: 10G-50G *1: with Ethernet daughter board; 2: with Wi-Fi antenna	

Edge to Cloud System Architecture

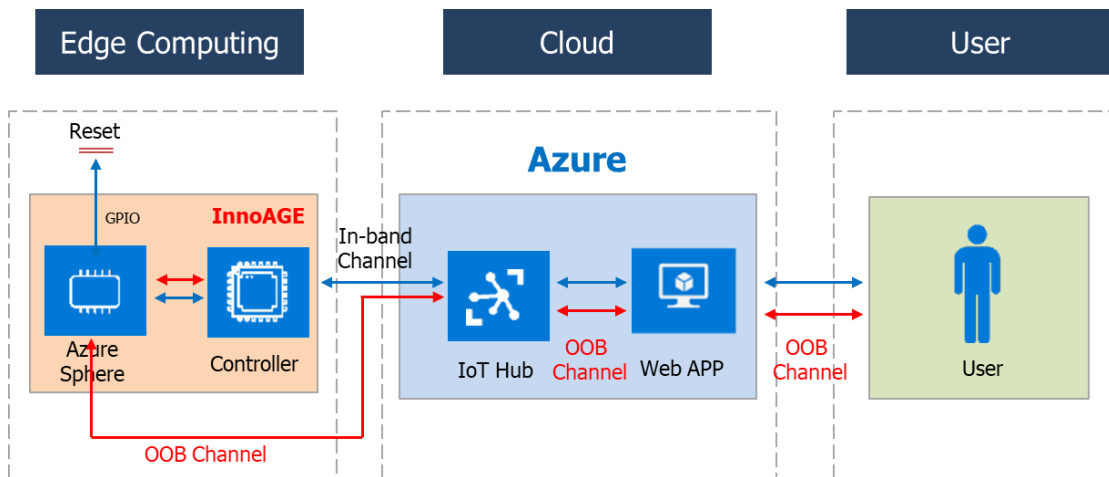

InnoAGE M.2 (S80) External Pin Definition

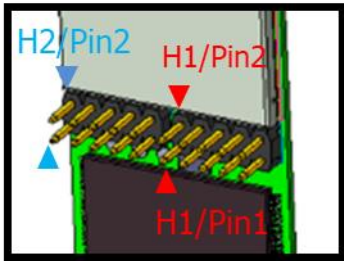

Pin Header 1 Recovery, Reset and External Reserved GPIO

PC_RST	Recovery	GPIO 66	GPIO 68	GPIO 0
H1/Pin 1	H1/Pin 3	H1/Pin 5	H1/Pin 7	H1/Pin 9
H1/Pin 2	H1/Pin 4	H1/Pin 6	H1/Pin 8	H1/Pin 10
GND	GND	GND	GND	GND

Pin	Function	Direction	Notification
1	RC_RST*	O	Active low
	GPIO	I/O	Bi-direction, function programmable
3	Recovery*	I	Active low
	GPIO	I/O	Interrupt-capable and bi-direction, function programmable
5	GPIO	I/O	Bi-direction, function programmable
	TX	O	TX of UART, pair with pin 7
7	GPIO	I/O	Bi-direction, function programmable
	RX	I	RX of UART, pair with pin 5
9	GPIO	I/O	Interrupt-capable and bi-direction, function programmable
	PWM	O	PWM control, frequency/duty TBD
2/4/6/8/10	GND		System GND

* Default setting function
 V_o range: $-0.28 < V_{OL} < 0.4$; $2.4 < V_{OH} < 3.63$ (V)
 V_i range: $-0.28 < V_{IL} < 0.28$; $2.0 < V_{IH} < 3.63$ (V)

Pin Header 2

SPI to Ethernet

INT	MISO	CLK	RST	GND
H2/Pin 1	H2/Pin 3	H2/Pin 5	H2/Pin 7	H2/Pin 9
H2/Pin 2	H2/Pin 4	H2/Pin 6	H2/Pin 8	H2/Pin 10
NC	NC	MOSI	CS	3.3V

Pin	Function	Direction	Notification
1	INT*	I	Interrupt-capable GPIO
	PWM	O	PWM control, frequency/duty TBD
	GPIO	I/O	Bi-direction, function programmable
3	MISO*	I	MISO of SPI interface, pair with pin 5/6/8
	DATA	I/O	CLK of I2C interface, pair with pin5
	RX	I	RX of UART, pair with pin 5/6/8
	GPIO	I/O	Bi-direction, function programmable
5	CLK*	O	CLK of SPI interface, pair with pin 3/6/8
	TX	O	TX of UART, pair with pin 3/6/8
	GPIO	I/O	Bi-direction, function programmable
6	MOSI*	O	MOSI of SPI interface, pair with pin 3/5/8
	CLK	I/O	CLK of I2C interface, pair with pin 3
	RTS	O	RTS of UART, pair with pin 3/5/8
	GPIO	I/O	Bi-direction, function programmable
7	RST	I	SSD module reset pin, active low
8	CS*	O	CS of SPI interface, pair with pin 3/5/6
	CTS	I	CST of UART, pair with pin 3/5/6
	GPIO	I/O	Bi-direction, function programmable
10	3V3		System power 3.3V
9	GND		System GND
2/4	NC		No internal connection
<p>* Default setting function V_O range: $-0.28 < V_{OL} < 0.4$; $2.4 < V_{OH} < 3.63$ (V) V_I range: $-0.28 < V_{IL} < 0.28$; $2.0 < V_{IH} < 3.63$ (V)</p>			

Mechanism Design

1. InnoAGE M.2 (S80)

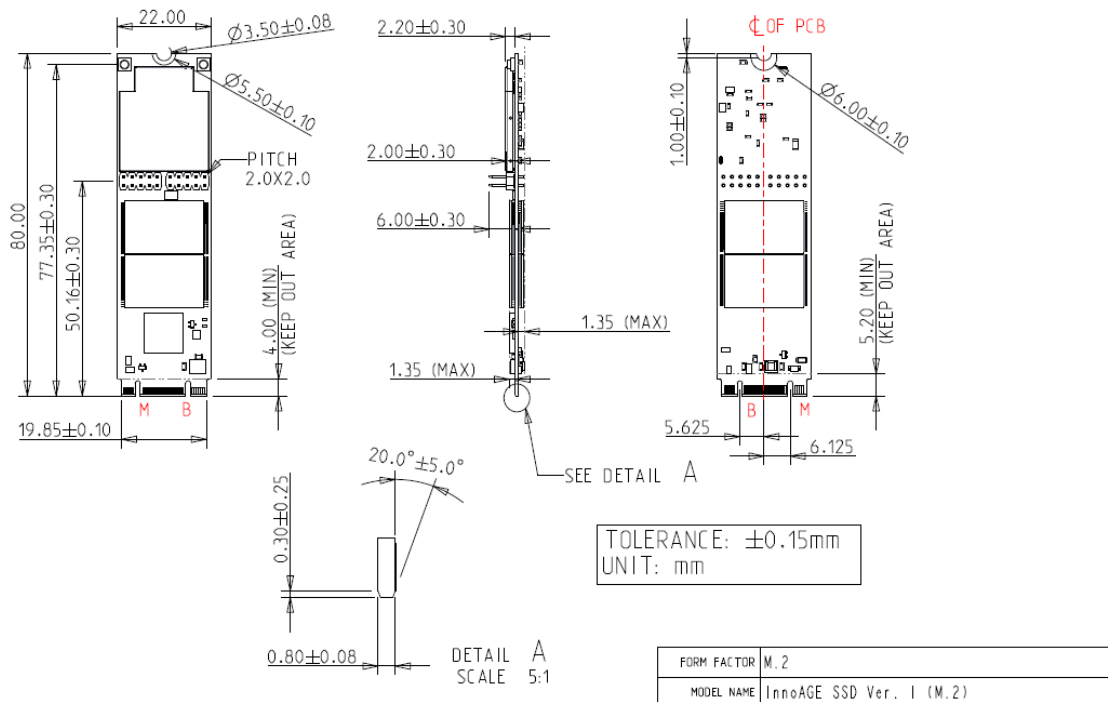

2. WiFi Antenna

Standard	IEEE 802.11 a/b/g/n and 802.11 ac
Frequency	2.4 to 2.49 GHz, 4.9 to 5.8GHz
Peak gain	3.5 dBi @2.44 GHz, 5.8 dBi @5.5 GHz
CSWR	<2.1
Feed impedance	50 ohms
Power handling	30 dBm
Interface	RPSMA
Antenna dimensions	$\phi 13.0$ mmx198.0mm
Weight	27.8g
Temperature range	-30°C to 75°C
Cover material (color)	Plastic (black)
Humidity range	5% to 95%

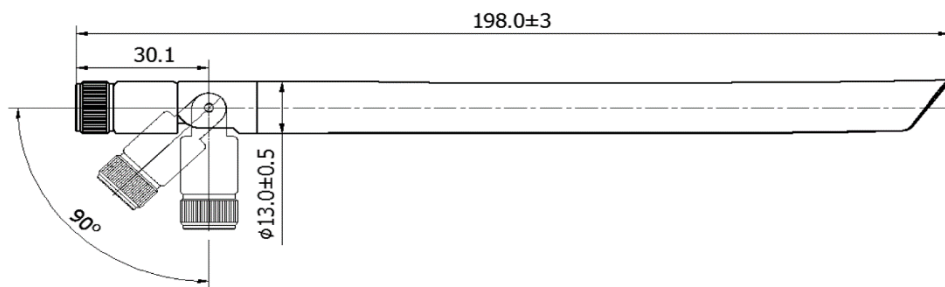

3. Ethernet Daughter Board

(1) Horizontal type

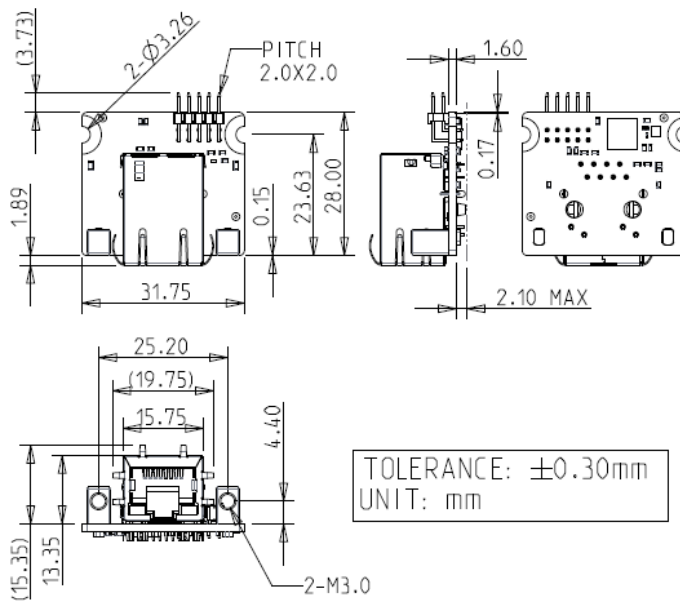

(2) Vertical type

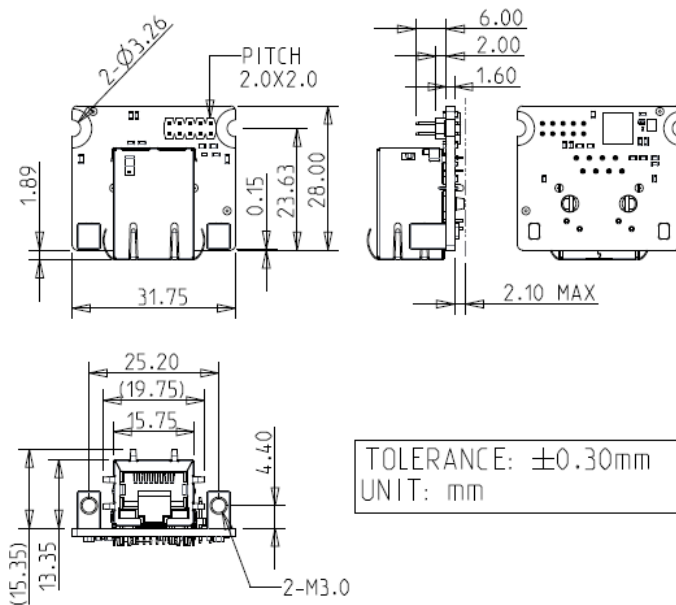

4. Cable Connection to Ethernet Daughter Board

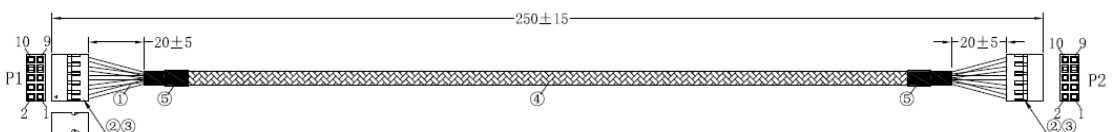

The Netherlands



Elektrostraat 17
NL-7483 PG Haaksbergen

T: +31 (0)53 573 33 33
F: +31 (0)53 573 33 30
E: nl@texim-europe.com

Belgium



Zuiderlaan 14 bus 10
B-1731 Zellik

T: +32 (0)2 462 01 00
F: +32 (0)2 462 01 25
E: belgium@texim-europe.com

UK & Ireland



St. Mary's House, Church Lane
Carlton Le Moorland
Lincoln LN5 9HS

T: +44 (0)1522 789 555
F: +44 (0)845 299 22 26
E: uk@texim-europe.com

Germany North



Bahnhofstrasse 92
D-25451 Quickborn

T: +49 (0)4106 627 07-0
F: +49 (0)4106 627 07-20
E: germany@texim-europe.com

Germany South



Martin-Kollar-Strasse 9
D-81829 München

T: +49 (0)89 436 086-0
F: +49 (0)89 436 086-19
E: germany@texim-europe.com

Austria



Warwitzstrasse 9
A-5020 Salzburg

T: +43 (0)662 216 026
F: +43 (0)662 216 026-66
E: austria@texim-europe.com

Nordic region



Sdr. Jagtvej 12
DK-2970 Hørsholm

T: +45 88 20 26 30
F: +45 88 20 26 39
E: nordic@texim-europe.com

Italy



Via Matteotti 43
IT-20864 Agrate Brianza (MB)

T: +39 (0)39 971 3293
F: +39 (0)39 971 3293
E: italy@texim-europe.com

General information



info@texim-europe.com
www.texim-europe.com