

Distributed by:



Features

- 15.6" New Generation Stainless Steel Panel PC
- Intel Celeron J6412 Processors
- True Flat Front Bezel Design and Grade 304 Stainless Steel Enclosure (Grade 316 for Option)
- IP66/IP69K Rated with M12 Connectors
- Ultra Slim Front Frame Design
- Special Hygienic Bolts on Rear Case
- Waterproof Wireless Antenna Covers to Solve the Bend Damage and Easy to Clean
- Support Ergonomic Versatile Mounting:
VESA Mount 100 x 100 / Floor Stand / Swing ARM

Specifications

System	
CPU	Intel Celeron J6412 (2.0GHz) Processor
System Chipset	SoC
Memory	1 x 260-pin SO-DIMM up to 32GB DDR4 3200MHz
TPM	TPM 2.0

IO Port	
USB	1 x M12 8-pin for 2 x USB 2.0 with waterproof cover
Serial / Parallel	1 x M12 8-pin COM1, RS-232/422/485, default RS-232, with waterproof cover
LAN	1 x M12 8-pin for LAN with waterproof cover
Power Connector	1 x M12 3-pin for DC power with waterproof cover 1 x Power switch on the rear
Option	2 x optional blank M12 connector with waterproof cover for selecting two from the following options: 2 x USB 2.0 1 x USB 3.2 Gen.1 1 x HDMI 1 x LAN 1 x COM

Storage Space	
M.2	1 x M.2 B-Key 2242/2280 for SSD (SATA3)

Expansion	
Expansion slot	1 x Full-size mini PCIe slot for 4G/5G 1 x Micro SIM slot 1 x M.2 E-Key 2230 for WiFi/BT module
RFID module	RFID module design on the front side (for option)

Display	Standard		High Brightness Optional	
	15.6" TFT-LCD		15.6" TFT-LCD	
Display Type	default	optional	default	optional
Max. Resolution	1366 x 768	1920 x 1080	1366 x 768	1920 x 1080
Max. Color	16.7M	16.7M	16.7M	16.7M
Luminance (cd/m ²)	400	500	1000	1000
View Angle	170(H)/160(V)	178(H)/178(V)	160(H)/160(V)	170(H)/170(V)
Contrast	500:1	1000:1	500:1	1000:1
Backlight Lifetime	50,000 hrs	50,000 hrs	50,000 hrs	50,000 hrs

Touch Screen	
Type	Projected Capacitive Touch
Interface	USB
Light Transmission(%)	90%

Dimensions

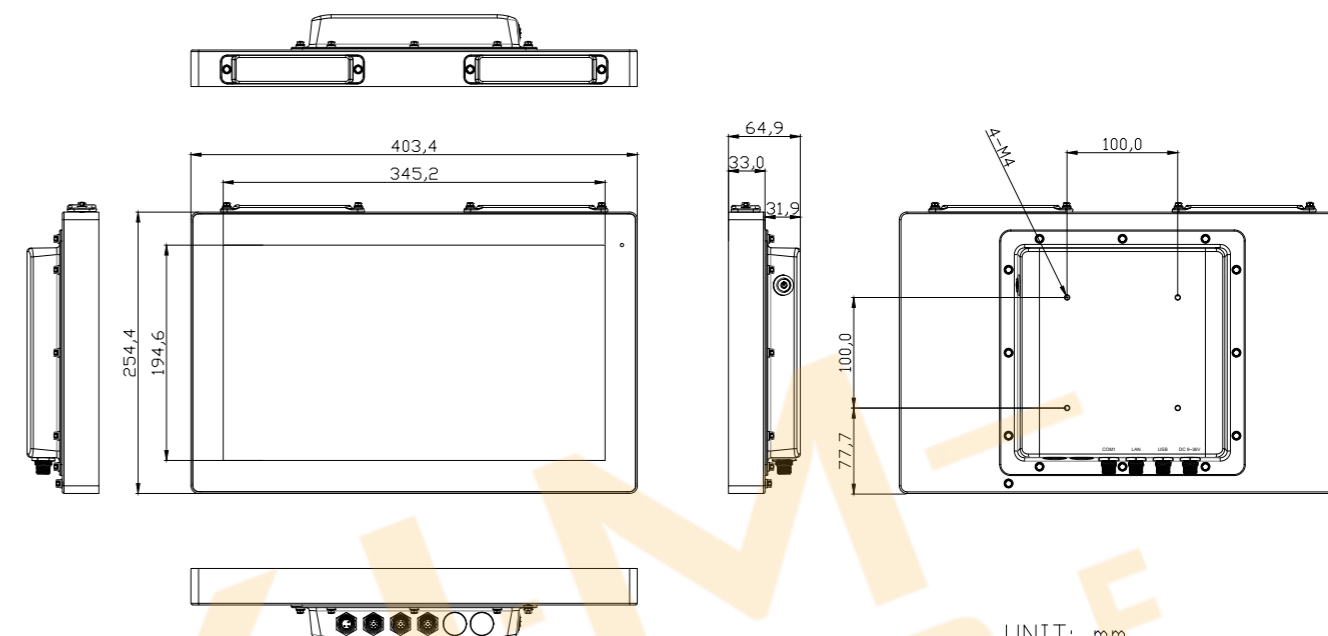
 UNIT: mm
 Tolerance: +0.5

Power	
Power Input	DC 9~36V
Power Consumption	PhanTAM-816BPH: 35W

Mechanical	
Construction	304 Stainless Steel Chassis (default), 316 Stainless Steel Chassis (optional)
Mounting	VESA Mount 100 x 100, Floor Stand / Swing ARM (optional)
IP Rating	Total IP66/IP69K
Dimensions	404.4 x 225.4 x 64.9 mm
Net Weight	5 kg

Environmental	
Operating Temperature	0~50°C (WT1: -20~60°C for optional)
Storage Temperature	-30~70°C
Humidity	10 to 90% @ 40°C, non-condensing
Certificate	CE/FCC Class A

Operating System Support	
Windows 10 IoT ENT LTSB, Windows 11	

Ordering Information	
PhanTAM-816BP	15.6" WXGA IP66/IP69K stainless steel panel pc, Intel Celeron J6412 Processors, 1 x SO-DIMM DDR4 slots, 128GB TLC SSD, projected capacitive touch, 9~36V DC power input with Adapter
PhanTAM-816BPH	15.6" WXGA IP66/IP69K stainless steel panel pc, Intel Celeron J6412 Processors, 1 x SO-DIMM DDR4 slots, 128GB TLC SSD, projected capacitive touch, 9~36V DC power input with Adapter, 1000 nits

Disclaimer

ALL PRODUCTS, PRODUCT SPECIFICATIONS AND DATA ARE SUBJECT TO CHANGE WITHOUT NOTICE TO IMPROVE RELIABILITY, FUNCTION OR DESIGN OR OTHERWISE.

Texim Europe B.V. its affiliates, agents, and employees, and all persons acting on its or their behalf (collectively, “Texim”), disclaim any and all liability for any errors, inaccuracies or incompleteness contained in any datasheet or in any other disclosure relating to any product.

Texim makes no warranty, representation or guarantee regarding the suitability of the products for any particular purpose or the continuing production of any product.

It is the customer’s responsibility to validate that a particular product with the properties described in the product specification is suitable for use in a particular application.

Parameters provided in datasheets and / or specifications may vary in different applications and performance may vary over time.

All operating parameters, including typical parameters, must be validated for each customer application by the customer’s technical experts.

Please contact us if you have any questions about the contents of the datasheet.

This may not be the latest version of the datasheet. Please check with us if a later version is available.



Headquarters & Warehouse

Elektrostraat 17
NL-7483 PG Haaksbergen
The Netherlands



T: +31 (0)53 573 33 33
E: info@texim-europe.com
Homepage: www.texim-europe.com



The Netherlands

Elektrostraat 17
NL-7483 PG Haaksbergen

T: +31 (0)53 573 33 33
E: nl@texim-europe.com



Belgium

Zuiderlaan 14, box 10
B-1731 Zellik

T: +32 (0)2 462 01 00
E: belgium@texim-europe.com



UK & Ireland

St Mary's House, Church Lane
Carlton Le Moorland
Lincoln LN5 9HS

T: +44 (0)1522 789 555
E: uk@texim-europe.com



Germany - North

Bahnhofstrasse 92
D-25451 Quickborn

T: +49 (0)4106 627 07-0
E: germany@texim-europe.com



Germany - South

Martin-Kollar-Strasse 9
D-81829 München

T: +49 (0)89 436 086-0
E: muenchen@texim-europe.com



Austria

Warwitzstrasse 9
A-5020 Salzburg

T: +43 (0)662 216 026
E: austria@texim-europe.com



Nordic

Søndre Jagtvej 12
DK-2970 Hørsholm

T: +45 88 20 26 30
E: nordic@texim-europe.com



Italy

Martin-Kollar-Strasse 9
D-81829 München

T: +49 (0)89 436 086-0
E: italy@texim-europe.com